**IMPROVING
WORKING CONDITIONS
AND PRODUCTIVITY IN
THE GARMENT INDUSTRY**

RECEIVED
SEP 17 1993
Industrial
Engineering Office
ILO - GENEVA BIT



45408

IMPROVING WORKING CONDITIONS AND PRODUCTIVITY IN THE GARMENT INDUSTRY

An action manual

edited by Juan Carlos Hiba

International Labour Office Geneva

Copyright © International Labour Organization 1998
First published 1998

Publications of the International Labour Office enjoy copyright under Protocol 2 of the Universal Copyright Convention. Nevertheless, short excerpts from them may be reproduced without authorization, on condition that the source is indicated. For rights of reproduction or translation, application should be made to the Publications Bureau (Rights and Permissions), International Labour Office, CH-1211 Geneva 22, Switzerland. The International Labour Office welcomes such applications.

Libraries, institutions and other users registered in the United Kingdom with the Copyright Licensing Agency, 90 Tottenham Court Road, London W1P 9HE (Fax + 44 171 436 3986), in the United States with the Copyright Clearance Center, 222 Rosewood Drive, Danvers, MA 01923 (Fax + 1 508 750 4470), or in other countries with associated Reproduction Rights Organizations, may make photocopies in accordance with the licences issued to them for this purpose.

Hiba, Juan Carlos

Improving working conditions and productivity in the garment industry: Practical ideas for owners and managers of small and medium-sized enterprises
Geneva, International Labour Office, 1998

/Management development guide/, /Working conditions/, /Labour productivity/, /Management/, /Small-scale industry/, /Clothing industry/. 13.03.1

ISBN 92-2-110849-X

ILO Cataloguing in Publication Data

The designations employed in ILO publications, which are in conformity with United Nations practice, and the presentation of material therein do not imply the expression of any opinion whatsoever on the part of the International Labour Office concerning the legal status of any country, area or territory or of its authorities, or concerning the delimitation of its frontiers.

The responsibility for opinions expressed in signed articles, studies and other contributions rests solely with their authors, and publication does not constitute an endorsement by the International Labour Office of the opinions expressed in them.

Reference to names of firms and commercial products and processes does not imply their endorsement by the International Labour Office, and any failure to mention a particular firm, commercial product or process is not a sign of disapproval.

ILO publications can be obtained through major booksellers or ILO local offices in many countries, or direct from ILO Publications, International Labour Office, CH-1211 Geneva 22, Switzerland. Catalogues or lists of new publications are available free of charge from the above address.

Preface

Improvements in working conditions and work organization can result in increased productivity and competitiveness. This has been clearly demonstrated in Asia, Latin America and Africa by entrepreneurs of small and medium-sized enterprises who have taken voluntary action to improve working conditions and productivity.

In 1988, the ILO published two manuals on *Higher productivity and a better place to work: an Action manual*, addressed to owner-managers of small and medium-sized enterprises, and a *Trainers' manual*. These manuals have been used in numerous awareness-raising and training workshops, as part of the Office's technical advisory services and for technical cooperation projects. They have encouraged improvements in different types of individual enterprises making products such as iron castings, furniture, footwear, small household appliances, food and beverages, paper, tiles and cement pipes, and glass.

In 1994, it was decided to develop training materials targeted at a particular industry or sector. The garment industry was selected because of its significant contribution to economic growth in many countries and because it is a major source of foreign-exchange earnings. It is also a major employer of women. Improving working conditions and productivity in this industry could thus result in making these small and medium-sized enterprises more competitive, efficient and safer, and also extend better protection to women workers.

This publication follows a similar approach to the manuals on *Higher productivity and a better place to work*, written by J.E. Thurman, A.E. Louzine and K. Kogi. It shows how to take simple, effective, low-cost action to raise productivity while improving conditions at the workplace. Some of the technical topics covered include handling and storage of materials, lighting, workstation and product design, safe and efficient machine operation, workplace layout, welfare facilities and work organization. The examples given are drawn from actual situations and experiences of owners and managers of small enterprises producing garments. All of them have voluntarily participated in training programmes organized by the ILO. The emphasis is on the implementation of practical, low-cost and locally appropriate measures directly related to productivity. Practical tools for

assessing conditions of work, planning the process of change, involving workers and assessing productivity are also given.

We are indebted to many individuals and institutions for the ideas and examples used in this book. We benefited from their contributions to technical cooperation projects and national programmes such as the project financed by the UNDP (United Nations Development Programme) on Improving Working Conditions and Productivity in Small- and Medium-sized Enterprises in the Philippines, the FINNIDA (Finnish International Development Agency) financed project on Training and Information Project for African Countries on Occupational Safety and Health in the United Republic of Tanzania, and the national programme entitled *Melhor Ambiente de Trabalho, Maior Produtividade* (Better working environment, higher productivity) carried out and funded by the *Serviço Brasileiro de Apoio as Micros e Pequenas Empresas* (SEBRAE). In particular, we are grateful to the following for their substantial contributions: the Bureau of Working Conditions and the Regional Offices of the Department of Labor and Employment, the Agro-Industrial Management and Consultancy, Inc., and Mr. William Salter, Senior Specialist, ILO Multidisciplinary Team for South-East Asia and the Pacific, in the Philippines; the Factories Inspectorate (Ministry of Labour), the National Institute of Productivity, the Moshi-Arusha Occupational Health Service (MAOHS), and Mr. Vesa Tornberg, Associate Expert of the FINNIDA project, in the United Republic of Tanzania; and Ms. Regina Heloisa Maciel, Departamento de Psicologia Experimental, Universidade de São Paulo, Brazil.

We also express our appreciation to the hundreds of owners and managers of small and medium-sized enterprises who opened their doors and made it possible to organize the training courses. Their experience and enthusiastic support provided the substance of this publication. Special thanks to employers' organizations, productivity centres, training institutions and ministries of labour that participated in organizing the training courses.

Colleagues in the Conditions of Work Branch provided considerable technical, administrative and secretarial back-up to complete this publication. Acknowledgements are

due to Mr. Juan Carlos Hiba, for coordinating the contributions of various individuals and for the technical editing, and to Ms. Simone Didero, Ms. Joan Robb and Ms. Helen Wielander for typing the many revisions to the final text. Prof. Nigel Corlett of the University of Nottingham, Mr. Peter Hasle from the Centre for Alternative Social Analysis in Copenhagen, Mr. Malcolm Pugh, Pugh Management Consultants, United Kingdom, and Mr. Michael Henriques, Entrepreneurship and Management Development Branch of the ILO, all

provided valuable technical comments and useful suggestions to improve the draft. Last but not least, our thanks to the Publications Bureau for their assistance in processing this publication, and to the International Training Centre of the ILO in Turin for the illustrations.

We hope that this publication will lead to improvements in the conditions of work in small and medium-sized garment-producing enterprises, and thus to a better working life for thousands of workers, especially women workers.

F.J. Dy-Hammar

Chief

Conditions of Work Branch

Working Conditions and Environment Department

Contents

Preface	v
----------------------	----------

PART 1

Chapter 1: Introduction	3
What this book is all about	3
How to use this book	5
Chapter 2 Efficient materials storage and handling	7
Better organized storage	7
If in doubt, take it out	7
Avoid placing materials on the floor	7
Gain productive space by introducing multi-level racks	10
Provide a place for each tool and work item	10
Fewer, shorter and more efficient transport and handling operations	12
The more you use it, the closer it should be	12
Provide containers for operation outputs and inputs	13
Use mobile storage	14
Clear and mark passageways	15
Fewer and more efficient lifting operations	15
Don't lift loads higher than necessary	15
Move materials and perform tasks at working heights	18
Make lifting more efficient and safer	18
Chapter 3 Practical workstation and product design	21
Placing materials, tools and controls within easy reach	21
Improve work posture for greater efficiency	23
Design your garments for easy assembly, low waste and high quality	28
Use guides to easily check measurements of pieces and garments	28
Use jigs and other devices to save time and effort	29
Improve displays and controls to minimize mistakes	32
Chapter 4 Productive machine safety, maintenance and environmental control	35
Give your machines a productivity check	35
Machine safety	35
Purchase safe machines	37
Maintain machines properly	38
Teach workers to troubleshoot common machine problems	39
Environmental control measures	42
Clean regularly and properly – do not spread dust	42
Make local ventilation cost-effective	43
Replace a dangerous substance with a safer one	44

Chapter 5	Good lighting for quality products	45
	Make full use of daylight	45
	Avoid glare	47
	Choose an appropriate visual work background	47
	Find the right place for light sources	49
	Use the right lighting device and fixture	50
	Avoid shadows	50
	Ensure regular maintenance	53
Chapter 6	Premises suited to production	55
	Protect your premises from outside heat and cold	55
	Let nature help you	57
	Improve the heat reflection of the walls and roof	57
	Improve heat insulation	57
	Use shades to protect against heat from the sun	57
	Let natural air-flow improve ventilation	58
	Make better use of horizontal air-flow	58
	Utilize the tendency of hot air to rise	61
	Improve your floor surface	61
	Build flexibility and adaptability into your plant layout	62
	Prevent fires and electrical accidents	64
	Fire	64
	Electrical hazards	65
Chapter 7	Effective work organization	67
	Eliminate extra tasks and operations	67
	Defeat monotony to keep workers alert and productive	68
	Install planned buffers to make the work flow smoothly	68
	Ensure work-in-progress is under control	68
	The Kanban method	69
	Provide adequate training and retraining	70
	Design responsible, flexible jobs	70
	Specify individual tasks and responsibilities	70
	Combine production operations and tasks	70
	Set up semi-autonomous or autonomous groups to improve efficiency and reduce supervisory cost	71
	Arrange the production layout to meet enterprise objectives	73
	Improve the sequencing of your production facilities	74
	Choose the most appropriate layout	75
	Set up a production progress control system	78
	Designing the system	79
	Implementing the system	79
Chapter 8	Low-cost work-related welfare facilities and benefits	83
	Make sure essential facilities serve their purpose	83
	Drinking water	83
	Sanitary facilities	85
	Be ready for emergencies	86
	Make sure that rest means recovery	87
	Rest breaks	87
	Rest areas	87
	Use low-cost facilities to attract and retain the best workers	88
	Work clothes	88
	Lockers and changing rooms	88
	Eating areas	89
	Canteens	89
	Health facilities	90

Transport facilities	90
Recreational facilities	91
Child-care facilities.	91
Birthdays and anniversaries	92

Chapter 9 Ensuring sustainable improvements	93
Develop a complete solution	93
Make sure your ideas will work	93
Mobilize worker support.	94
Make improvements which will last.	94
Manage change.	95
Supervise improvements carefully.	95
Make improvement a systematic process.	95
Take action	96

Chapter 10 More constructive worker involvement	97
Why should workers be involved?	97
How should workers be involved? Ways and means for a successful approach	98
Provide more information about your enterprise	99
Create conditions for participation	99
Let the workers assess the workplace and express their ideas	99
Implement a small change	100
Set up a core group of workers.	100
Involve all workers.	100
Provide appropriate training.	101
Enrich workers' jobs	101
Organize workers in teams	102
Monitor and review the process	102

PART 2

Section 1 Useful productivity techniques.	105
1. Benefits of productivity measurement	105
2. What is productivity?	106
3. Basic productivity measurement	106
4. How to measure productivity	107
Qualitative productivity indicators.	107
Non-standard quantitative productivity indicators	107
Standard productivity indexes	108
5. How to measure output and input.	109
6. WISE-PMS application in the garment industry	109
7. Steps in implementing a productivity measurement system	112

Annex to Section 1: Model forms for the WISE Productivity Measurement System.	115
Individual production report.	115
Group production report	118
Attendance personnel record	120
Delivery performance record	122
Accident record	124
Preventive maintenance record.	126
Customer complaints record.	128
Energy consumption record	130
Employee turnover record	132

Section 2	Three effective checklists for action	135
	Checklist 1: Improving general workplace conditions	136
	Checklist 2: Organizing better sewing workstations	145
	Checklist 3: Involving workers in the process of change	148
Section 3	An exercise to simulate the use of the Kanban method	151
Section 4	Balancing the production line	153
Section 5	Three techniques for improving your layout	155
	The string diagram	155
	The travel chart	156
	Weighted travel charts	159
Section 6	Checklist 4: How to implement improvements	161
Section 7	Model forms for an action plan	164

PART 1



Introduction

If you own or manage a small or medium-sized enterprise producing garments, you are responsible for an important contribution to the national economy. People depend on you for jobs and for your products. Most of the social and economic growth in almost every country is expected to come from small or medium-sized enterprises. Your small enterprise, together with the others in your country, provides employment for many people, pays taxes, utilizes raw materials and consumes energy. Your suppliers and clients are interested in your garments and you want to respond better to an expanding demand. Whether you supply mainly the domestic market or manufacture for export, both markets now demand higher quality and better value for money. The globalization of the economy offers new opportunities and challenges but for these you need to be prepared.

In spite of their importance, many small or medium-sized clothing industries fail to grow or even to survive. It is not easy to succeed in the garment industry. Problems of finance, production and marketing lead thousands to bankruptcy every year. Studies have shown that the average enterprise loses half its customers in five years and half its employees in four years.

This is a book about survival and growth through building a more effective enterprise. The ideas you will find in this book are practical and low cost. Many of them may already be in use in your own enterprise or in similar companies nearby.

As an entrepreneur, you are no doubt very busy. You have to face so many day-to-day problems that you may not have had the time to take a close look at some parts of your production process to see if they can be improved. Limitations on productivity and quality may have built up unnoticed. A small investment of your time could have a big impact.

What this book is all about

The practical ideas you will find here are the result of several years of ILO action in cooperation with owners and managers just like you. In each case, the starting point was a concern for survival and growth of the enterprise.

Many entrepreneurs were asked the question: "**How can you reduce costs and improve your production operations?**" Their answers are probably a lot like yours; they include:

- minimize waste of raw materials
- cut damage to work items
- increase quality of work
- improve maintenance and repair of sewing machines and equipment
- introduce more efficient layout and work methods
- cut idle sewing machine time and reduce wasted time of workers
- reduce stocks and organize production more effectively
- allow more efficient change-over to new products.

A second question was also asked: "**How can workers help?**" Predictably, entrepreneurs replied that workers could improve their performance in many ways, including:

- learning more skills
- paying more attention to productivity and quality
- taking better care of all machines and equipment
- avoiding absences and lateness and working harder
- keeping the interests of the enterprise in mind
- adapting faster to production changes and following rules
- meeting quotas and standards
- avoiding accidents and making useful suggestions.

Any enterprise which can reduce costs, increase productivity and improve quality is likely to survive and grow. This means that you need to:

- make the best possible use of your machines, equipment and facilities; and
- achieve the highest levels of commitment and efficiency from the workers.

Neither of these goals is simple to accomplish. There are constant problems to be solved in a small and medium-sized factory such as yours. You may have to cope with inappropriate machines; too small a building; problems with electricity, water or transport; poor quality raw materials; and unskilled or poorly motivated workers.

This book indicates some basic principles and gives many examples of improvements which have a direct impact both on your production facilities and operations, and on the motivation and efficiency of workers. The vast majority of the improvements are concrete and very practical.

Part 1 of this book includes many low cost examples which are shown in the following technical topics:

- **Efficient materials storage and handling.** Storage and handling by themselves are not sources of additional value as during these operations goods do not acquire any new qualities. Discover why improved materials storage and handling can (among other advantages) recover misused space, and lower capital costs due to less work-in-progress and simplified stock control.
- **Practical workstation and product design.** Many workers perform the same task hundreds of times per day. The benefits of small improvements are thus multiplied many times and simple changes can produce large payoffs. Find how the use of jigs or fixtures, for example, adapted to the design of products can help produce easy-to-assemble garments.
- **Productive machine safety, maintenance and environmental control.** Breakdowns and accidents affect production operations resulting in delays or poor quality. Low-cost guards installed in sewing, cutting and transfer machines protect fingers and help prevent accidents and keep people at work. Exposure to solvents used for cleaning oil stains causes fatigue and headaches and high levels of dust and cloth fibres require extra cleaning and may spoil finished products. See how it is possible through simple and inexpensive means to control most of these problems.
- **Good lighting for quality products.** Better lighting very often increases productivity and reduces difficulties and eye strain for workers. This is important for detailed work or in workstations carrying out quality control tasks. But does better lighting necessarily mean higher costs? By no means; if you make use of daylight and regular cleaning and maintenance of windows, skylights, etc., you can improve lighting while reducing the electricity bill.
- **Useful premises serving production.** Make your premises work for you. Much can be done, even with older buildings, to improve ceilings, walls and floors to improve production. The impact of simple measures to control ventilation, heat and pollution can be dramatic.
- **Effective work organization and work processes.** Simple organization techniques such as recombining tasks and setting up buffer stocks are easy to introduce for immediate benefits. Introducing multi-skilling, developing group workstations and organizing production around products have numerous advantages. These include smoother and more efficient work flow, higher product quality, greater workforce flexibility, reduced down-time of expensive machines and less need for costly supervision.

- **Low cost work-related welfare facilities and benefits.** Good welfare facilities are an essential part of any enterprise producing garments. They improve the workers' attendance, job satisfaction, motivation, morale and health. You will be surprised at the many opportunities you have for low-cost investments in this important issue.

In addition to these seven technical themes included in Chapters 2 to 8, Part 1 contains two chapters which provide **practical procedures** to help you take action, involve your workers in the process of change and assess the impact of the changes.

Chapter 9 helps you with the systematic **implementation of improvements**, especially when dealing with complicated or difficult ones. It also explains how the introduction of improvements can become a permanent process of change in your enterprise, not just a one-time measure. You will learn why it is important to prepare your own action plan for change.

Chapter 10 offers a **series of guidelines** to ensure quick and sustained worker involvement in making the process of change sustainable. You will discover why workers should be involved and learn techniques for a successful approach. From opening simple channels of information to setting up a core group of workers dealing with innovative production processes, you may select the way most appropriate to your enterprise.

Part 2 of the book includes a series of **sections with tools for action**. You will find procedures and examples for assessing productivity; several checklists for identifying possible improvements in working conditions; and forms and worksheets for keeping records of changes. Other practical tools supporting the guidelines introduced in the technical chapters of Part 1 are also included here.

Section 1 deals with **productivity**. The benefits of productivity measurement in the garment industry are explained, and you will learn about basic productivity methods and how to introduce them. You will be guided through the essential steps in implementing a low-cost productivity measurement system. This section includes a series of nine forms which can be used to record information useful for calculating productivity indexes.

Section 2 includes three **checklists** designed to discover weak points in production process while providing practical ideas for improving them. Most suggestions are easy to implement. You can apply these checklists to selected production areas or to the whole enterprise and they will help to prioritize the most important solutions.

Section 3 presents an **exercise** to simulate a new method for handling materials and work in progress (known as the Kanban method).

Section 4 introduces a *procedure* to help improve balancing of production lines.

Section 5 offers three *techniques* for improving the layout of production lines.

Section 6 presents a practical *checklist* that complements the information given in Chapter 9.

Finally, Section 7 of Part 2 includes a *model form* for drafting an action plan, together with an example.

How to use this book

Some of the entrepreneurs using this book will be participants in courses organized by employers' organizations, productivity centres, training institutions, labour ministries or other agencies. They will be able to go through the chapters in an organized and systematic way, and will have an opportunity to move very quickly to a continuing process of making improvements and profiting from them.

If you are using this book independently, you should try to develop the sort of opportunities offered by the courses. One of the best ideas is to work together with other owners and managers of similar enterprises. This will allow you to share ideas, learn how others have solved the same problems, see other enterprises in action and, in general, benefit from the knowledge and experience of people you can respect because they have successfully built up their own businesses. You may be able to organize a group of owners and managers through a trade organization or chamber of commerce, among neighbouring enterprises or among your friends who are interested in these matters. If you can organize a small group you should try to follow these basic steps:

- Carry out a checklist exercise (using some or all of the three checklists included in Section 2 of Part 2) for each enterprise in the group. Discuss the results and compile a list of priority actions.
- Discuss each of the technical chapters (see Chapters 2 to 8 in Part 1) and see if you can improve on your list of actions (use the form in Section 7, Part 2).
- Ask each group member to try one of the more complex improvements in this list as suggested by Chapter 9 on the implementation of changes. Discuss the results as a group.

- Discuss the most suitable procedures in each enterprise for involving workers in the process of change (see Chapter 10) and for assessing productivity (see Section 1 in Part 2).
- Carry out some of the improvements listed on your action plan (see Section 6 in Part 2). Meet with the group occasionally to talk about problems and new ideas.

It may seem to you that organizing a group is a lot of effort and that you would be better off spending the time in your own factory. You may also have some doubts about being exposed to criticism from others or about your production processes being copied. However, you may be surprised how many good ideas can come from practical people who look at your factory and production methods with a fresh eye; and helping other owners and managers, based on your own experience, is often enjoyable.

If you cannot organize a group of people with similar interests, you can still greatly profit from the ideas in this book. Use the checklists, study the chapters, involve your supervisors and workers, try out some improvements and then repeat the process. Working alone for improvements can also be effective as you can manage your time and resources independent of external pressures; but you do need to be persistent. Change and improvement are dynamic: if you stop, you will lose what you gained; if you continue, you will consolidate and build on what you have already accomplished.

Remember – continuous improvement is the road to survival and growth.

One final point: Enterprises should keep in touch with trade associations, government agencies, training organizations and local chambers of commerce for information, support and technical assistance. If you have followed a course organized by them, try to continue to benefit from follow-up and other activities. If you are working alone or in a small group, you may still be able to get technical help.

If you feel that a course should be organized, suggest this to a local agency or institute. They may be interested in setting up a programme which can expand your possibilities for action and growth. In preparing training seminars for employers it may be helpful for them to take a look at the *Trainers' manual for Higher productivity and a better place to work* published previously by the ILO. It provides substantive information for organizing effective seminars for owner-managers of small enterprises.

2

Efficient materials storage and handling

The storage and handling of raw materials, components and products is an integral part of most production processes. Done efficiently, it can ensure that work flows smoothly and helps to avoid delays and bottlenecks. However, storage and handling by themselves are not sources of additional value or profit, as during these operations, goods do not acquire any new qualities. Just the opposite happens: materials are damaged and lose their value, accidents occur and your scarce capital is tied up in unnecessary stock.

In this chapter, we discuss ways of attaining three goals:

- better organized storage
- fewer, shorter and more efficient transport and handling operations
- fewer and more efficient heavy lifting operations.

In each of these areas you will find ideas arranged according to a few basic rules. If you apply these ideas in your enterprise, you can expect numerous benefits, including recovery of space for production, more efficient materials flow, faster capital turnover, improved inventory control, reduction of time lost on unproductive work and a more orderly and attractive factory.

Better organized storage

If in doubt, take it out

Extra stock is a waste. It requires storage, record keeping and handling. It ties up capital and some costly materials can become spoiled or obsolete.

Leaving stock and work-in-progress around in the production area reduces the space available for production operations and impedes movement of workers. The more cluttered your shop-floor, the more likely materials and work-in-progress will be mixed up or lost. Workers spend valuable productive time looking for things.

Consider each piece of raw material, each box, each container, each tool, each machine. Is it in use? Is it really needed? If not, take it away.

Figures 1 and 2 show the same work area before and after unnecessary items were removed. Analyse the two figures for a while and respond to the following questions: do you feel the change has contributed to efficiency? To quality? Is it likely to make a better impression on customers?

Some of the most organized enterprises manufacturing garments practise a specialized inventory method known as "Kanban" or "just-in-time".¹ The basic principle is that materials are brought to the production area only as and when they are needed. This helps with stock control. If you want to compete, you should be willing to try the same idea. You will find more information on this subject in Chapter 7.

Avoid placing materials on the floor

Many small enterprises often complain about the lack of space in their workshops. On examination they find that a high percentage of floor space is taken up by redundant stock, raw materials scrap and old machines. Sometimes, some of these goods have been sitting there for years, getting dusty and dirty.

Production space is a premium that should not be wasted. A good layout reduces accidents and promotes health and safety for the workers. A poor layout increases material-handling, and manufacturing costs, creates bottlenecks and delays, and contributes to damaged goods.

The best approach is to provide special storage and containers for each productive item. It is not difficult to obtain and install storage racks, shelves and containers. For heavy items use wooden pallets. For light items use overhead space by installing overhead racks along walls that are less frequently used. Figures 3 and 4 show examples of basic systems. Workers should be trained to place raw materials and work-in-progress in racks and containers, and on shelves.

¹The basic idea of the Kanban or "just-in-time" (JIT) is that manufacturers make garments to order, thereby reducing the work-in-progress levels and the finished goods stock. Raw material is drawn from suppliers only when it is needed; then the succeeding stages of manufacture are drawn by each workstation from the preceding operation. Stock turnover is greatly improved leading to smaller warehousing facilities.

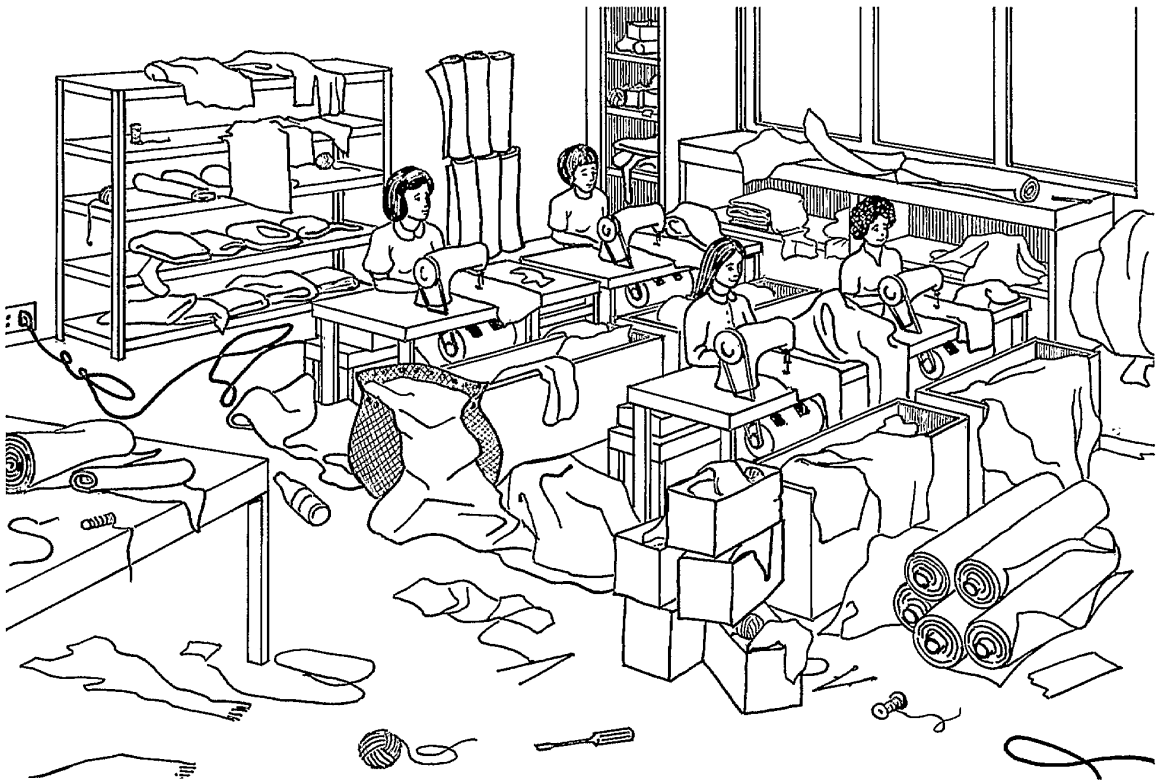

Figure 1: A cluttered shop-floor impedes the easy flow of material and workers, causing production delays, errors and accidents

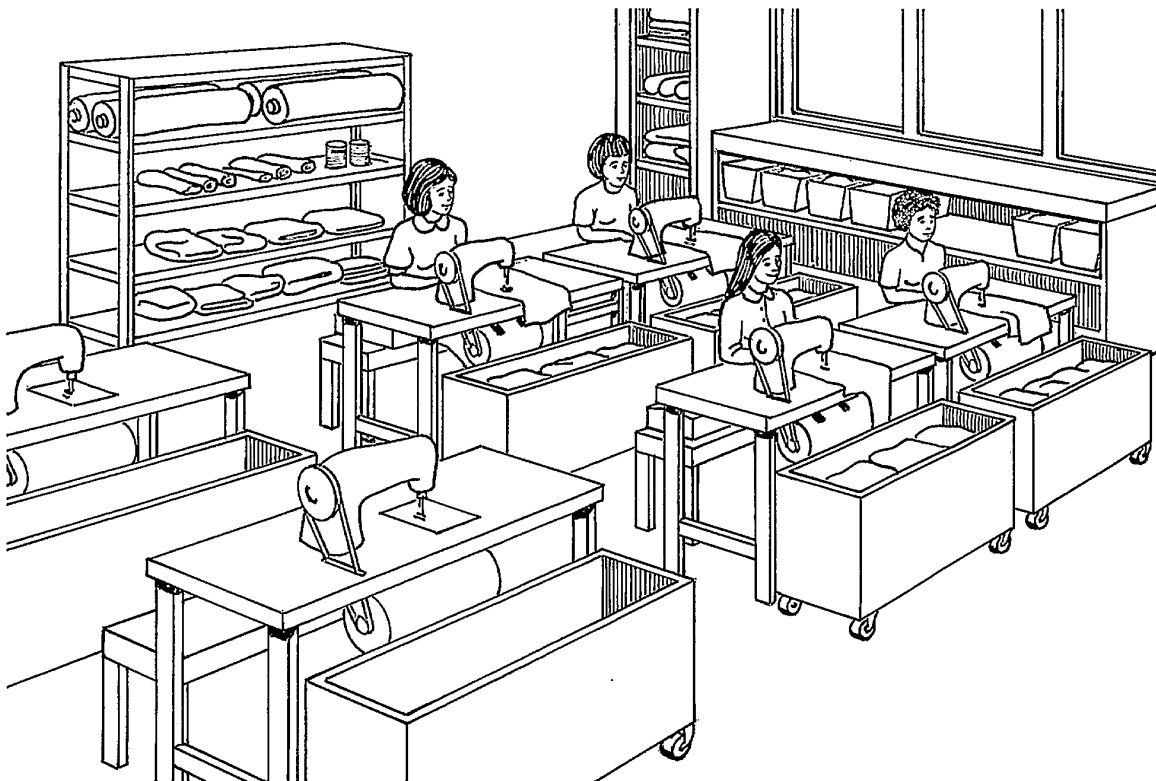

Figure 2: The same shop-floor after unnecessary items have been removed. Once floor space is retrieved, new workplaces could be added and the flow of work-in-progress is speeded up

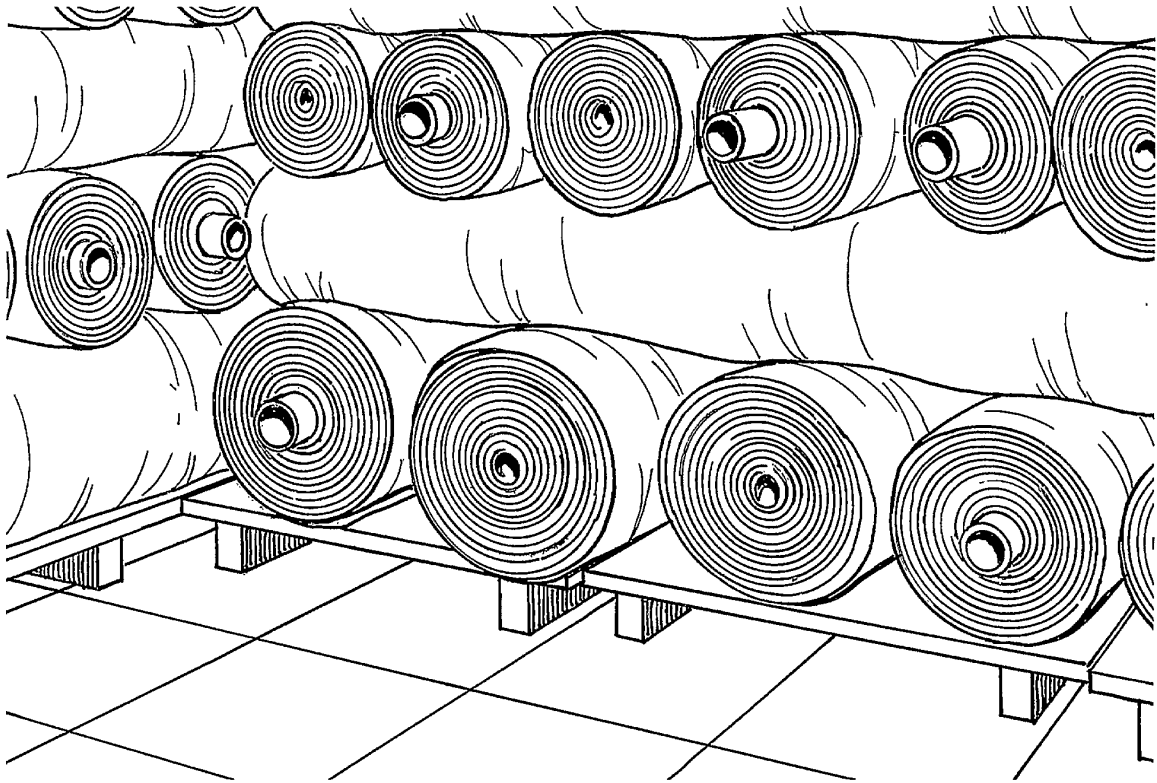

Figure 3: Wooden pallets keep fabric rolls off the floor, preventing damage to expensive material

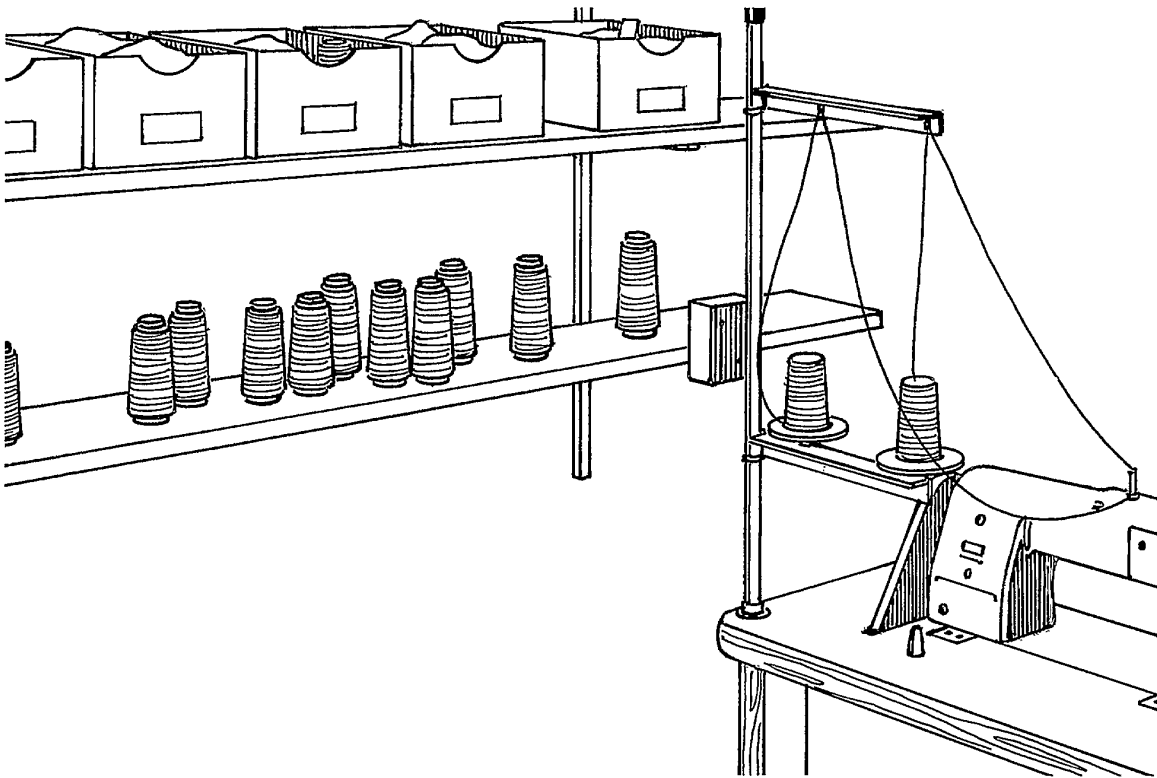

Figure 4: Light items like bobbin boxes, thread cone stands and small boxes containing needle-draws and other supplies can be stored overhead near workstations, using lightweight shelves

Gain productive space by introducing multi-level racks

The total wall space can be larger than the floor area of your production shop. Multi-level racks help you to use it fully. This means:

- savings in floor space
- easy accessibility to work items and tools
- improved inventory control.

Here are some examples:

Two models (figures 5 and 6) of heavy multi-level racks and shelves for garment parts or bundles, designed using metal or wooden material, to use wall space fully, and a wall cabinet (figure 7) for tool storage, are low-cost

practical solutions. Lighter, easy-to-assemble transport hanging and flat storage racks provide more flexibility for storage needs (figure 8).

Provide a place for each tool and work item

Observe your production process closely and it is very likely that you will find that some of your workers lose time in searching for lost tools, supplies and small work items. Even if you urge them today to put everything in order, in a few days you will find the same problems as before unless you allocate a special, permanent place and a holder or a container for each tool, supply or work item.

Consider the quantity, size, shape and weight of the necessary items in order to select the most appropriate means and place of storage.

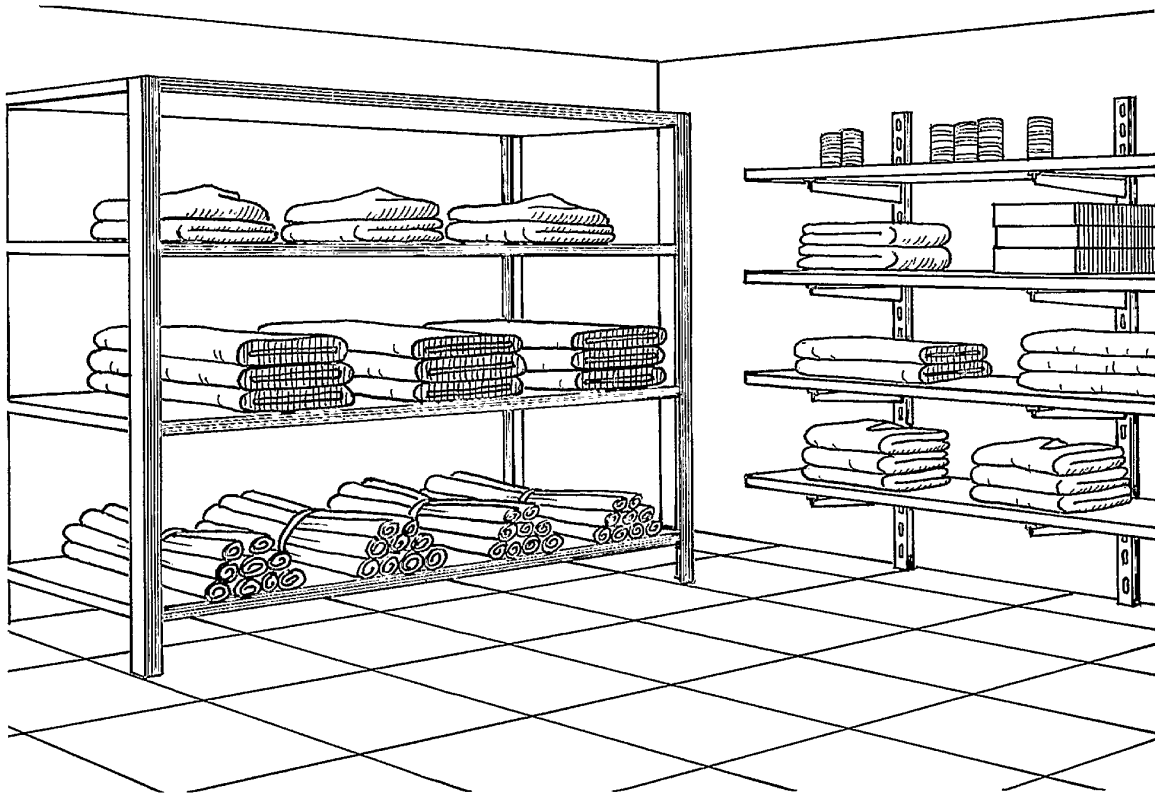

Figure 5: Multi-level racks save space and allow material to be temporarily stored in an orderly manner



Figure 6: Shelving designed to use wall space fully

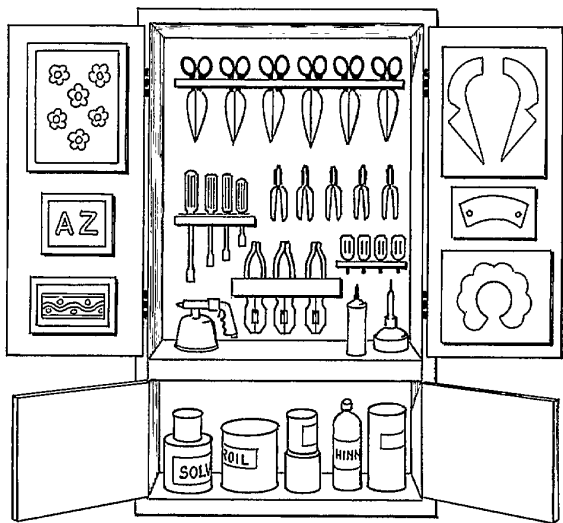

Figure 7: A wall cabinet for storage of die cuttings, small screens, tools and dangerous substances. Made of wood and equipped with four locking doors, it provides easy access to any tool and takes an absolute minimum of floor space

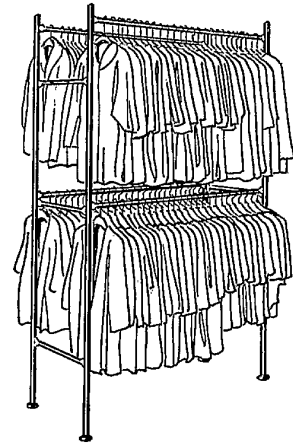

Figure 8: These two light storage systems are easy to assemble and dismantle, and quickly provide space for hanging or placing flat items which will soon be needed again



Little bins are appropriate for storage of small items, elastic, ribbons, bobbins, lace or labels. Front opening bins make the contents easy to see and provide ready access to the stock. The bins can be stacked or fixed on rotary racks in the storeroom. You can also use them for small parts and accessories like buttons, snaps, hooks and other supplies, as necessary, at the workbench (figures 9, 10, 11 and 12).

Fewer, shorter and more efficient transport and handling operations

Every time a worker handles a work item, time and energy are lost. *Analyse your work operations and see whether each handling operation is really justified. If not, find a way to eliminate it.*

The number of handling operations is closely related to the number of different tasks in the production process. It is

also related to the order in which machines and workstations are placed around the shop. This is part of the overall organization of production and layout of your workshop. It is discussed in Chapter 7, because you will need to consider the ideas from several chapters before you are ready to make complex improvements in work organization.

However, there are several things which you can do to improve handling operations without making any major organizational changes.

The more you use it, the closer it should be

In the next chapter on workstation design, you will learn how to ensure that all frequently used tools (scissors, nippers, tape measures), supplies (threads, needles, zippers) and accessories (buttons, lace) are within easy reach of the worker. Most used tools can be attached to the work table; supplies can be stored in small bins or

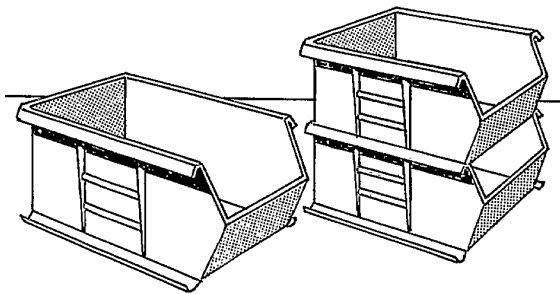

Figure 9

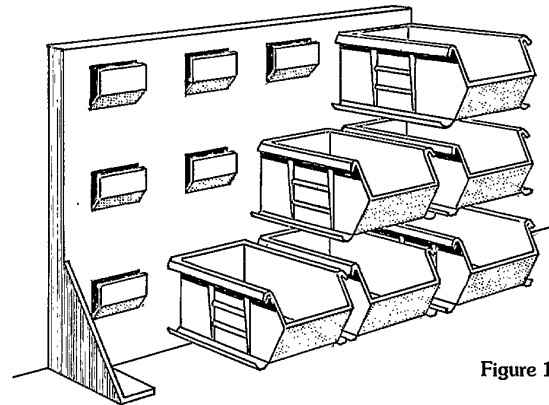

Figure 10

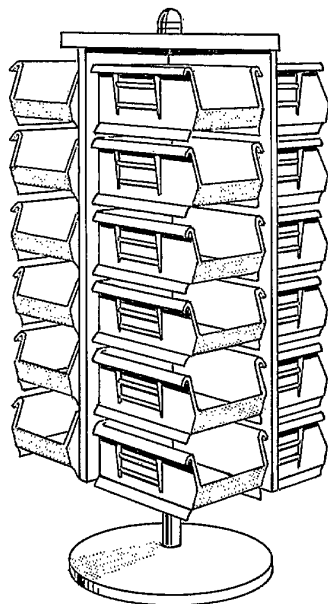

Figure 11

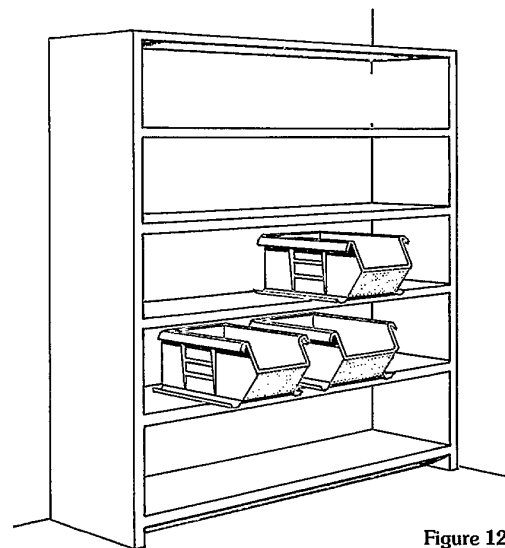

Figure 12

Figures 9, 10, 11 and 12: Hand bin containers (figure 9) for storage of small parts. The front opening makes the parts easy to see and provides ready access to the stock. The bins can be stacked at the workbench, placed on special racks (figure 10), on a rotatory rack (figure 11) or on regular shelves (figure 12)

boxes above or below the work table; small accessories can also be placed in small boxes or on special feeders. Less frequently used tools and supplies can be placed on shelves and racks next to the workstation or in a corner within the production area. Finally, tools needed only once or twice a day can be stored centrally (figure 13).

Provide containers for operation outputs and inputs

In line assembly systems like garment manufacturing, movement of work-in-progress to the next operation is very critical and should be made as easy as possible. For example, long tables could be installed along the row of machines so workers could just push work-in-progress from one operation to the next. Alternatively, the output of each operation could be placed in a suitable receptacle, which is then transferred to the next process.

Various types of work aids may be available in the local market such as baker trays, wheels and castors. Seek out

small engineering shops where specific aids can be manufactured to suit your needs. Consider the following for selecting appropriate containers:

- size and weight of bundle/garment pieces
- space requirement for moving and stocking containers
- durability
- means of transportation
- cost effectiveness.

Other specific design criteria for containers need to be taken into consideration if you want to achieve an efficient system of production:

- material, weight and size
- handles
- colours, labels or tags
- modularity and the possibility of stacking.

Make sure that the containers produce minimum crushing/crumpling and soiling to the material and are

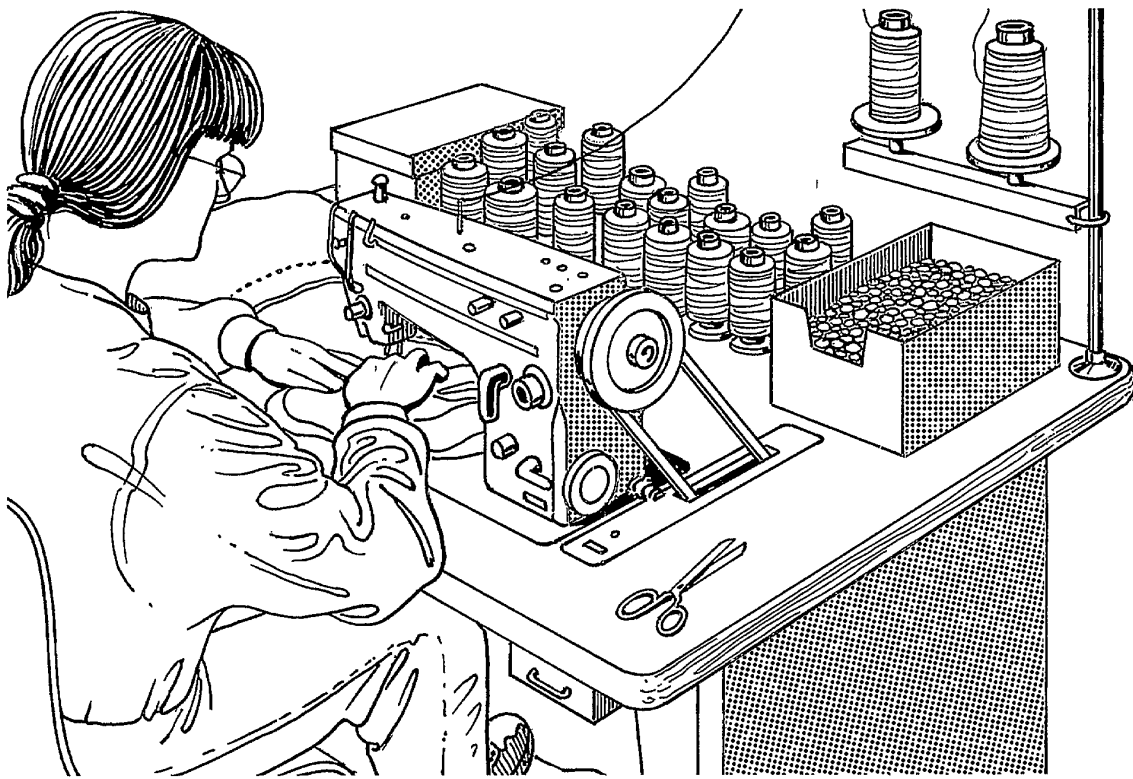

Figure 13: Time and energy can be saved by placing materials, tools and controls within easy reach. Longer reaches mean a loss of production time and unnecessary effort

Figure 14: Hanging-rails on wheels prevent crumpling of ready-to-deliver products and makes the transportation of finished items safer

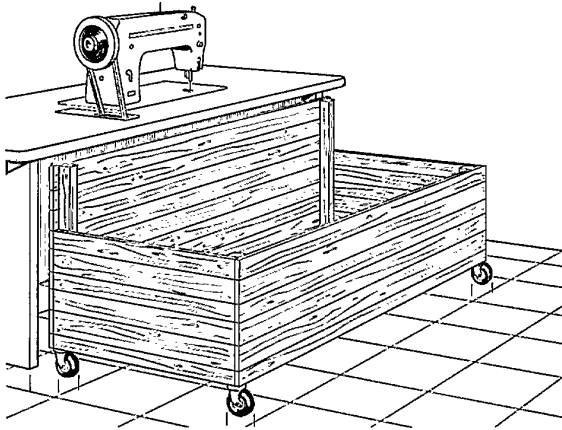
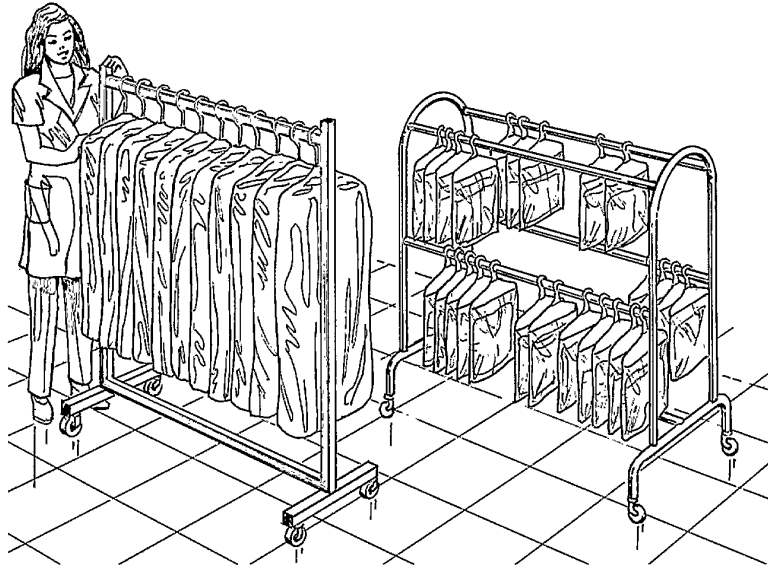

Figure 15: A shorter wooden container. The outer side and front covers are lower for ready grasping of material. The machine side is higher to ensure that the material does not fall on the floor from the machine

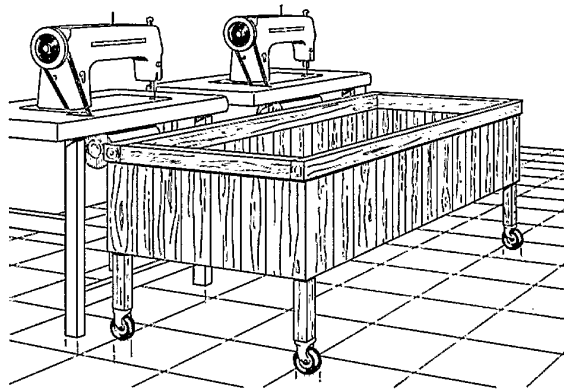

Figure 16: A big shallow container serving two adjacent sewing workstations. Shallow containers help prevent workers bending down too much

easy to move. Remember that what is put into a container by one operator will have to be taken out by another. It is better to select containers in which the products can lie or hang tidily than to have them jumbled up and difficult to see or pick up. Figure 14 shows hangers for short and long items to prevent crumpling. Figures 15 and 16 are examples of big containers only appropriate in enterprises where large lengths of fabric are sewn together, such as big bedspreads, curtains or tents.

Remember – put containers on wheels whenever possible.

Use mobile storage

Even after you have removed everything which is unnecessary from the shop-floor, you will have a large number of work items which need to be moved from one operation to the next, between workstations or between storage and work areas. Often this is done in a haphazard way, which can mean many extra trips, additional manpower and loose inventory control. If you think about handling materials when you design your storage arrangements, you can achieve the following:

- fewer material-handling operations
- less idle machine time
- increased layout flexibility
- reduced physical strain and injuries
- simple, effective inventory control
- reduced damage to work items
- cheaper and more efficient housekeeping.

A low-cost, easy to implement strategy is to transform static containers into movable ones. A good first step is to add rollers or castors to existing containers. You may also design low metal or wooden frames with castors to go under containers. Obtain new racks or containers with rollers or castors to move several items at the same time. Figures 17 and 18 show different containers or racks with castors for transporting materials, bundles and finished products.

Often this improvement is not implemented because it is easy to scoop several work items from a container manually and carry them to the next process. But if you consider the number of times workers have to go back and forth, as well as the inconvenience and the possible damage this procedure may cause to the work items, it would be better to use mobile containers. It is also good practice to keep the batches of work together through the whole manufacturing cycle; less work will get lost and the production process is easier to control if batches stay together.

For these mobile containers to be used efficiently, attention should also be paid to the smoothness of the floor surface (see Chapter 6). Care must be taken to ensure that the wheels on mobile material-handling equipment are of adequate width and diameter.

Clear and mark passageways

Very often movement of handling equipment is hampered by items scattered on the floor or by protruding containers and boxes. If the passageways are marked and cleared, then handling equipment can pass through easily and quickly, saving time and energy. Each workstation should keep its containers within well defined boundary lines. Keeping only necessary items within the work place will help keep passageways clear.

Figure 19 shows a plant layout with passageways clearly marked. When designing passageways, keep corridors and aisles wide enough to allow two-way transport.

Fewer and more efficient lifting operations

In small garment industries there are many handling and lifting tasks. Lifting operations are a prime source of accidents, damage and unproductive costs, and it is

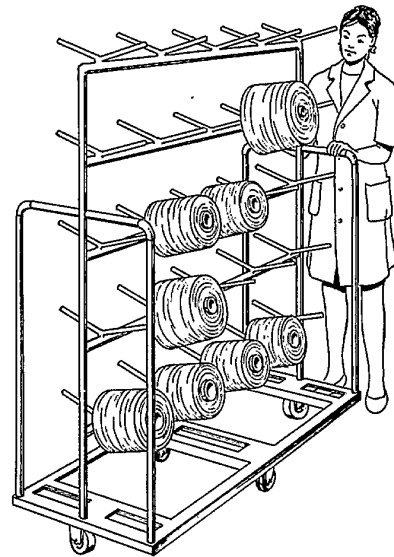

Figure 17: Special-purpose movable racks help workers to transport raw material to workstations

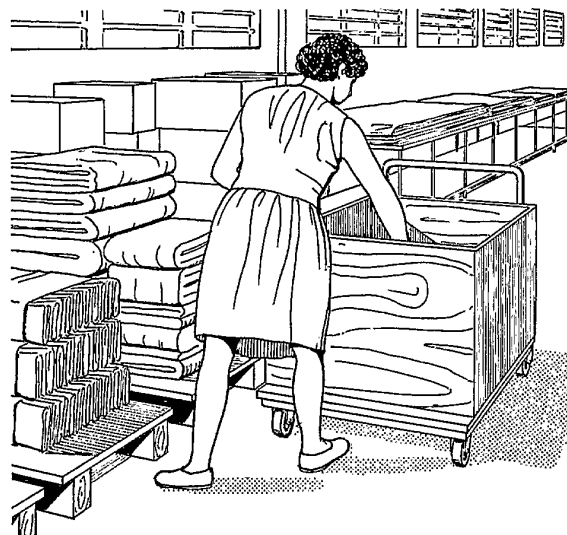

Figure 18: Multi-purpose carts are useful for transporting bulky items

better to eliminate them wherever possible. Lifting loads is usually combined with transport and the following rules will help to make this safer and more productive.

Don't lift loads higher than necessary

Time and physical effort can be saved by using platforms so that goods do not have to be lifted during loading and unloading operations. Where resources are available, design the loading area to match the height of the vehicle bed. Figure 20 shows a multipurpose low trolley. Figure 21 shows a loading area the height of which matches the vehicle bed. If this is not possible, provide material handling devices to reduce carrying before loading and after unloading.

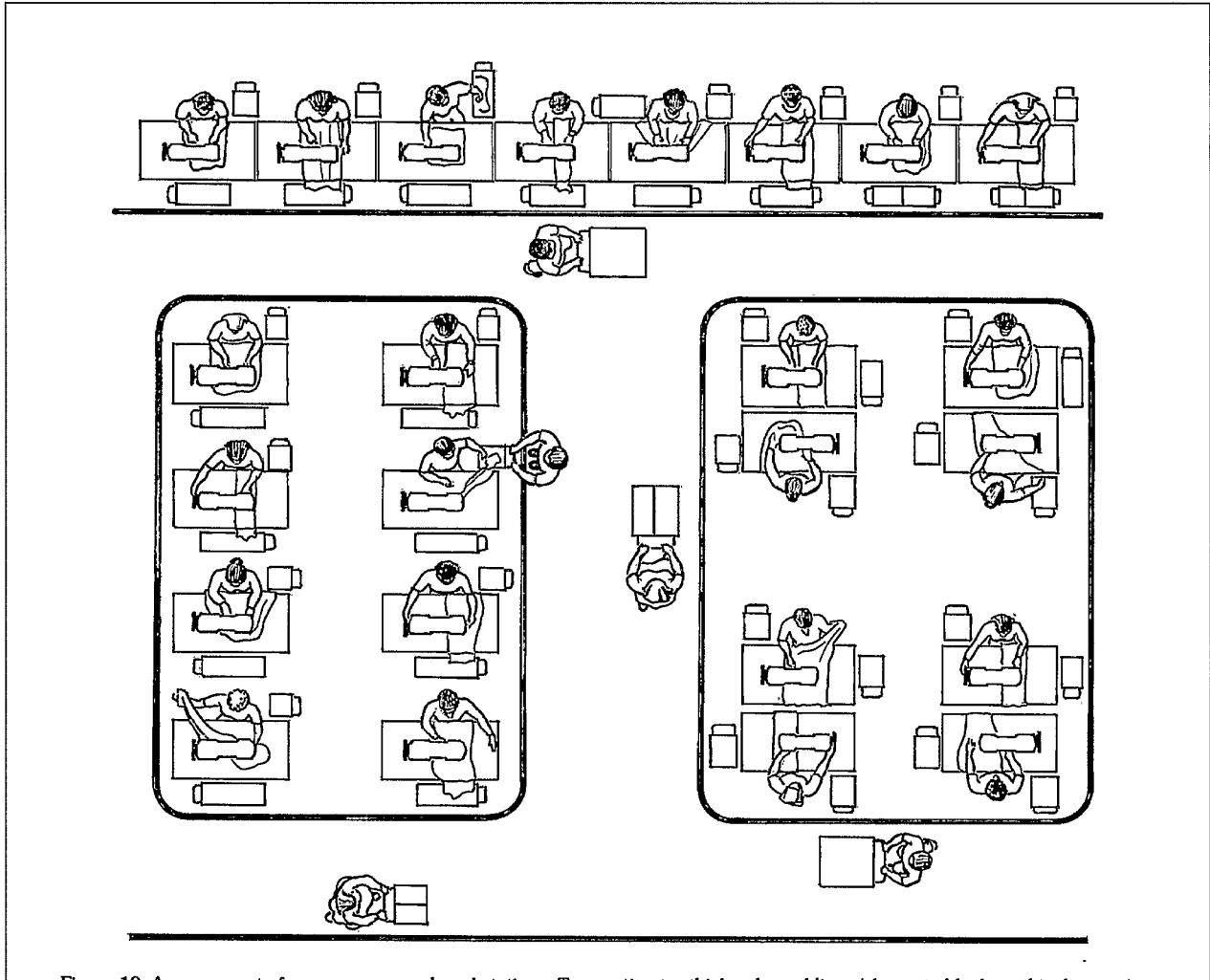

Figure 19: Arrangement of passageways and workstations. Ten-centimetre-thick coloured lines (shown in black on this diagram) painted on the floor help to define work areas and passageways

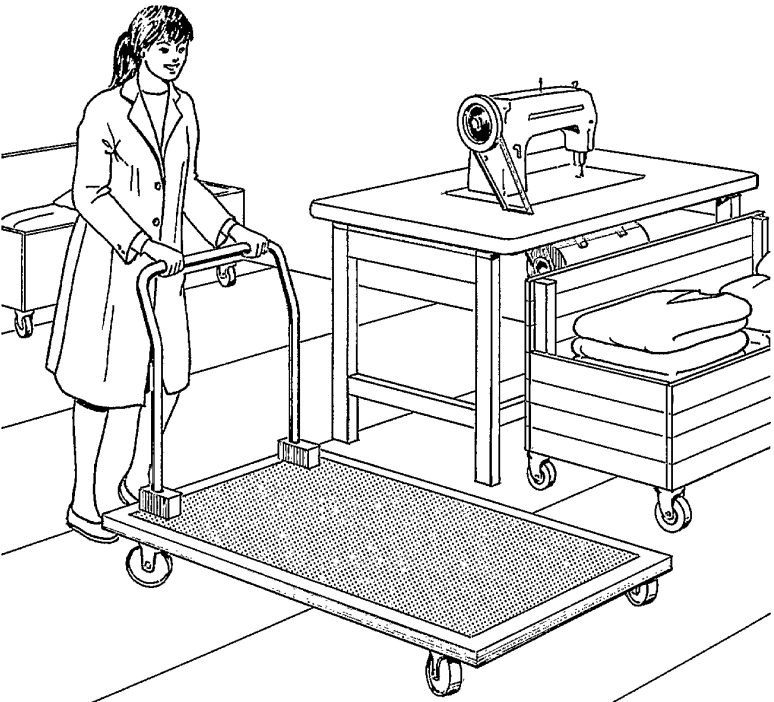

Figure 20: Bundles, containers and bolts can be loaded on this multi-purpose trolley. Its low platform allows boxes of different shapes and sizes to be stacked

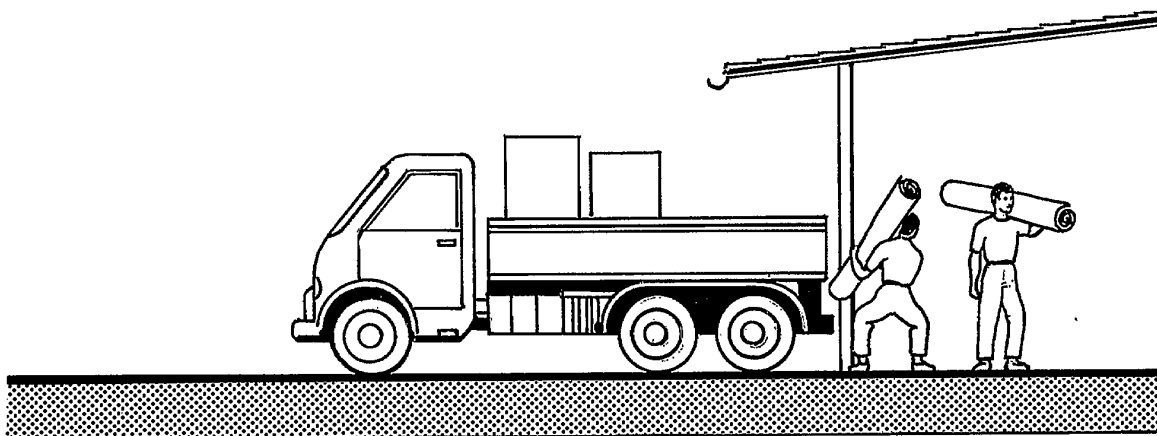
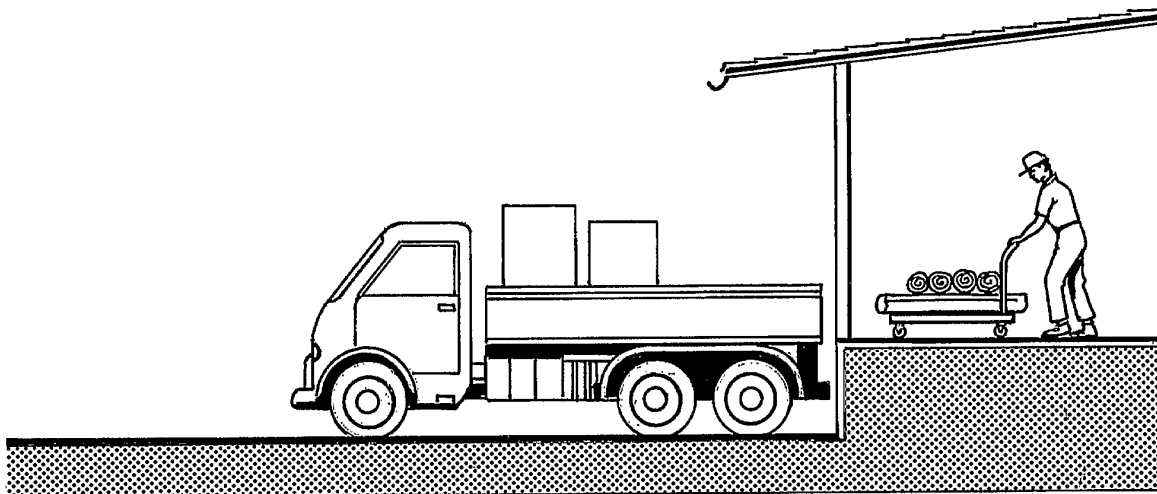
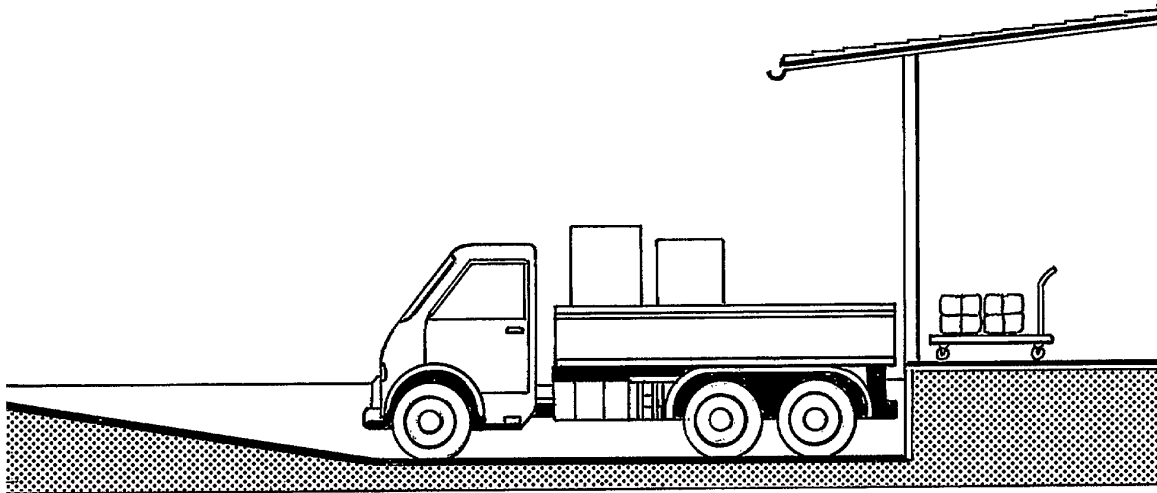

Figure 21: Matching the height of the vehicle bed to that of the loading bay prevents accident and unnecessary physical effort

In designing manual carrying methods, you should keep in mind the fact that the higher the load is carried, the more the percentage of physical energy spent on lifting and the less on actual transport.

Remember these guidelines:

- *minimize lifting*
- *provide good handles*
- *keep the load close to the body*
- *don't twist to pick up or put down a load*
- *handle things between hips and chest level*
- *handle only light objects above or below this level*
- *minimize bending or difficult reaching.*

Where possible, do not assign heavy lifting jobs to women and ensure that pregnant women do NOT lift heavy weights.

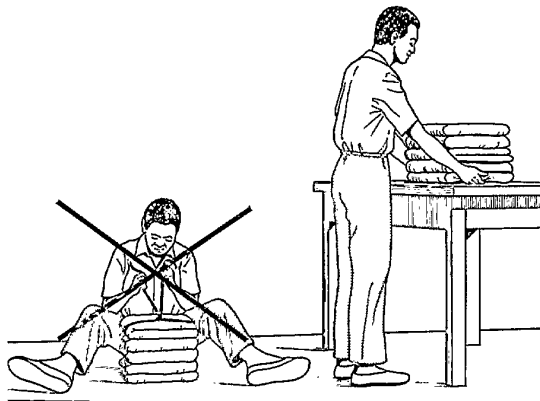

Figure 22: Workers should be discouraged from working on the floor. Their backs suffer and their productivity is low. Stable work tables and stools should be provided

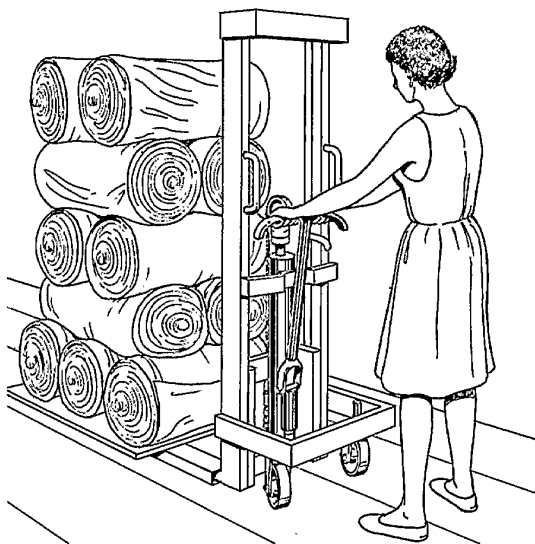

Figure 23: A low-lift pallet trolley is reliable, safe and easy to operate for carrying heavy loads a short distance with minimum elevation

Move materials and perform tasks at working heights

Unfortunately, we cannot always avoid the need to carry heavy fabric rolls or bulky bundles. Each time we put them on the floor, we will have to lift them up later which may cause back injuries. Wherever possible, all material handling should be performed at waist level and not on the floor. Some workers could prepare and tie bundles squatting on the floor but this uncomfortable position affects both their back and their productivity. Work tables and chairs should be provided and used (figure 22).

In selecting material-handling devices and when designing methods for manual carrying, give preference to the ones with minimum load elevation (figure 23). It is possible, and can be very profitable, to design and build special low-cost devices for handling different sized heavy items (figure 24).

Make lifting more efficient and safer

Manual lifting of heavy loads should be avoided. Manual lifts should be considered only as a last resort when mechanical aids are not available. When allocating tasks, consideration should always be given to the physical capacity of the least strong workers involved in the operation.

In organizing lifting work, remember that lowering and raising the body weight when taking weights up from the floor increases the required energy by 50 per cent as compared with lifting a weight from 0.5 metres above the floor. Where possible install platforms for loading and unloading heavy items.

You can help your workers to avoid back injuries by teaching them the correct lifting technique, i.e. keep the back straight and raise the load, using the muscle power of the legs and the grip of the hands, whilst keeping the load as close to the body as possible. Figure 25 shows a good way to lift heavy loads.

Dividing bundles into smaller parts before moving them should not be associated with lower productivity. It has been proved in practice that maximum efficiency is usually attained with weights below 20 kilograms. The physical capacity of a woman is on average about one-third lower than that of a man and her reach is also considerably shorter; this should be taken into account when assigning jobs which require lifting heavy weights, especially above shoulder level.

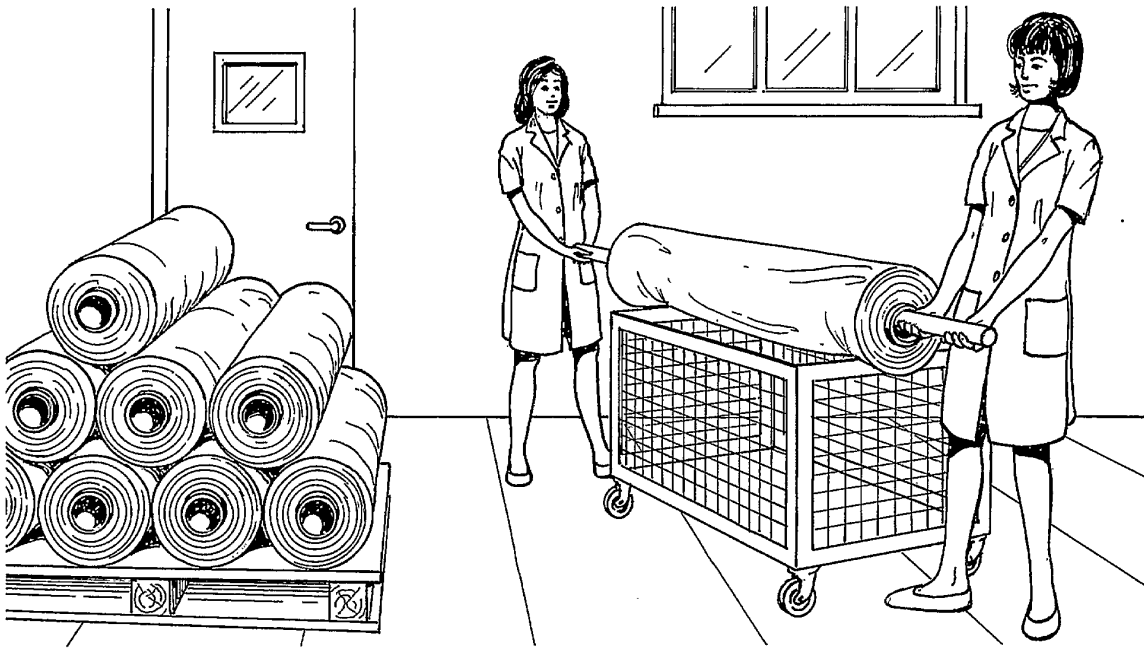

Figure 24: Heavy and bulky rolls of cloth can easily be handled and carried using one long rigid bar and a multi-purpose trolley. Alternatively, you can use two shorter wooden bars, inserting one in each end of the roll

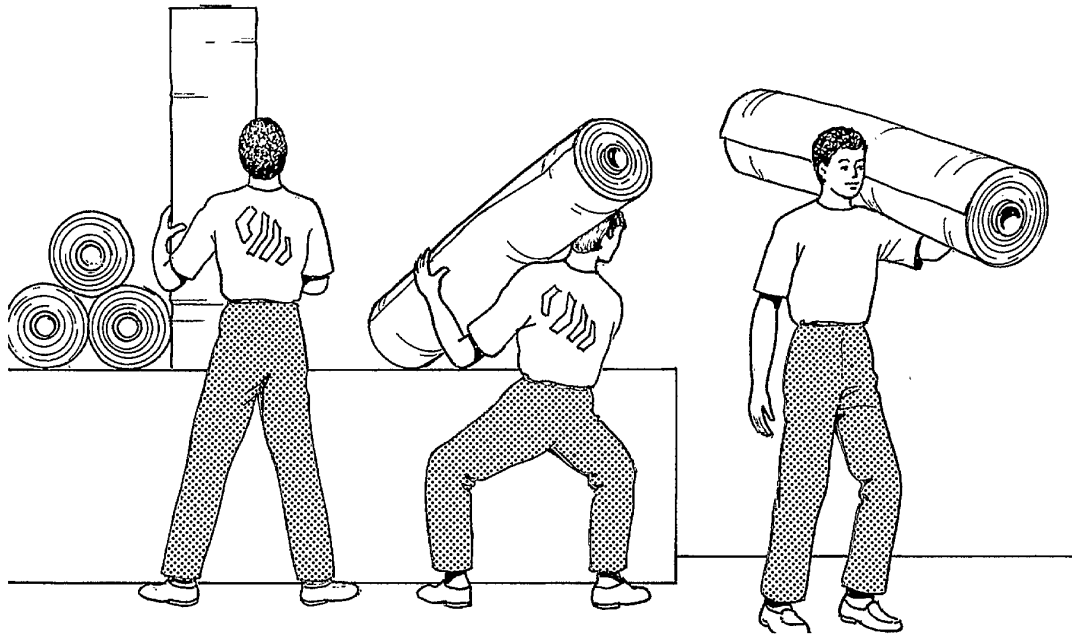

Figure 25: The correct technique for lifting heavy rolls from a platform. The higher the level of the roll above the floor, the less energy is required

Summary

Rules for efficient materials storage and handling

1. If in doubt, take it out.
2. Avoid placing materials on the floor.
3. Gain productive space by introducing multi-level racks.
4. Provide a place for each tool and work item.
5. The more you use it, the closer it should be.
6. Provide containers for operation outputs and inputs.
7. Use mobile storage.
8. Clear and mark passageways.
9. Don't lift loads higher than necessary.
10. Move materials and perform tasks at working heights.
11. Make lifting more efficient and safer.

3

Practical workstation and product design

A workstation is a place occupied by a worker when performing a job. The place may be one occupied all the time or may be one of several places where work is done. An example of a workstation is the area covered by a sewing machine, a chair, containers with incoming parts and finished pieces, and the nearby space in which the worker needs to move. In the case of a sewing workstation, this horizontal floor space is around four square metres. In cases where larger products are manufactured such as curtains, tents or rugs, this floor space can be as high as 6 to 8 square metres.

A well-designed workstation is important for productive work. Most workers in factories producing garments repeat the same or similar operations for the entire production lot which, if performed efficiently and quickly, can result in greater productivity.

Each workstation should be designed to suit the needs of a worker, the machine and the task to be performed. A well-organized workplace minimizes material handling, improves efficiency and reduces worker fatigue.

The existence of your enterprise relies on an efficient supply to the market. Survival and future growth is very much linked to your product, design, quality and service. Consistently manufacturing high quality goods usually leads to repeat orders.

Six rules for designing efficient workstations and good quality products are described below. Each one provides an opportunity for improvement and provides guidelines on how different production areas can be designed for efficiency. The cost of the following suggestions is minimal, yet they can produce considerable benefit.

Placing materials, tools and controls within easy reach

Search and select time can be saved by placing materials, tools and controls (such as switches, levers, pedals, etc.) within easy reach of the worker. Long reaches require additional time and effort from the worker. Therefore, the first rule for an efficient workstation is *“the more you use it, the closer it should be”*.

The distance that can be reached easily without leaning forward or stretching is quite small. Any object that is frequently grasped or used should be located between 15 to 40 cm from the front of the work-surface. Fixed locations assist the worker to develop good working habits, thereby reducing the “search and select” time required to grasp an object. Figure 1 shows some dimensions for normal and extended reaching areas accessible to a small person in a seated position. Taller workers will also work more comfortably in appropriately designed workstations.

Pointers for positioning tools are:

- identify tools that are most frequently used
- place the most frequently used tools in a location where they can easily be reached without leaning
- tools such as nippers and scissors which are constantly used could be attached to the machine table with a stretchable cord or hung around the worker’s neck
- tools such as pins could be kept in place by using magnets attached to the case of the machine or a padded strap attached to the sewing machine (figure 2).

Other small accessories for sewing, e.g. buttons, hooks, etc. could be placed in bins with tray for automatic dispensing or in boxes with proper labels. A small box with a basic maintenance toolkit should also find its place in the workstation.

Material inputs should be placed beside the worker to avoid unnecessary standing and walking (figure 3). Containers should also be provided for inputs and outputs so that all materials can be accumulated in one place and orderliness can be maintained in every workstation. Other points to remember are the following:

- make sure that the edges of the containers are smooth so the material can easily be removed without damage
- use containers that are not too deep to prevent the worker having to bend or twist. If possible, use stackable containers
- use containers that are movable for faster transport to the next operation.

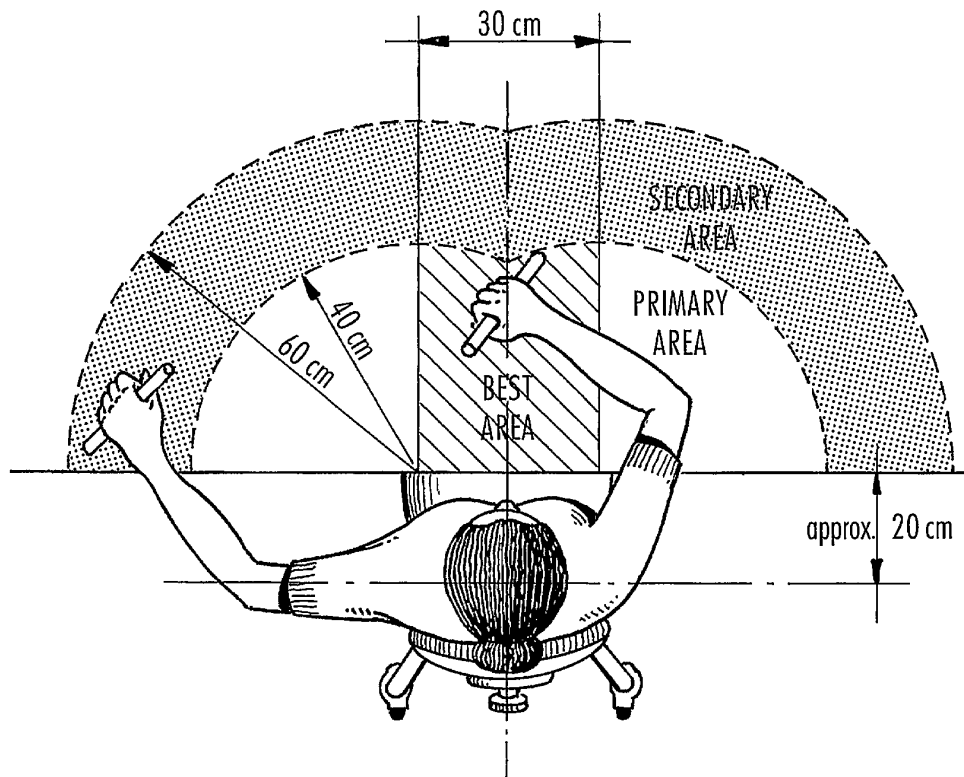

Figure 1: Normal and extended reach areas at table-top height for a seated small worker

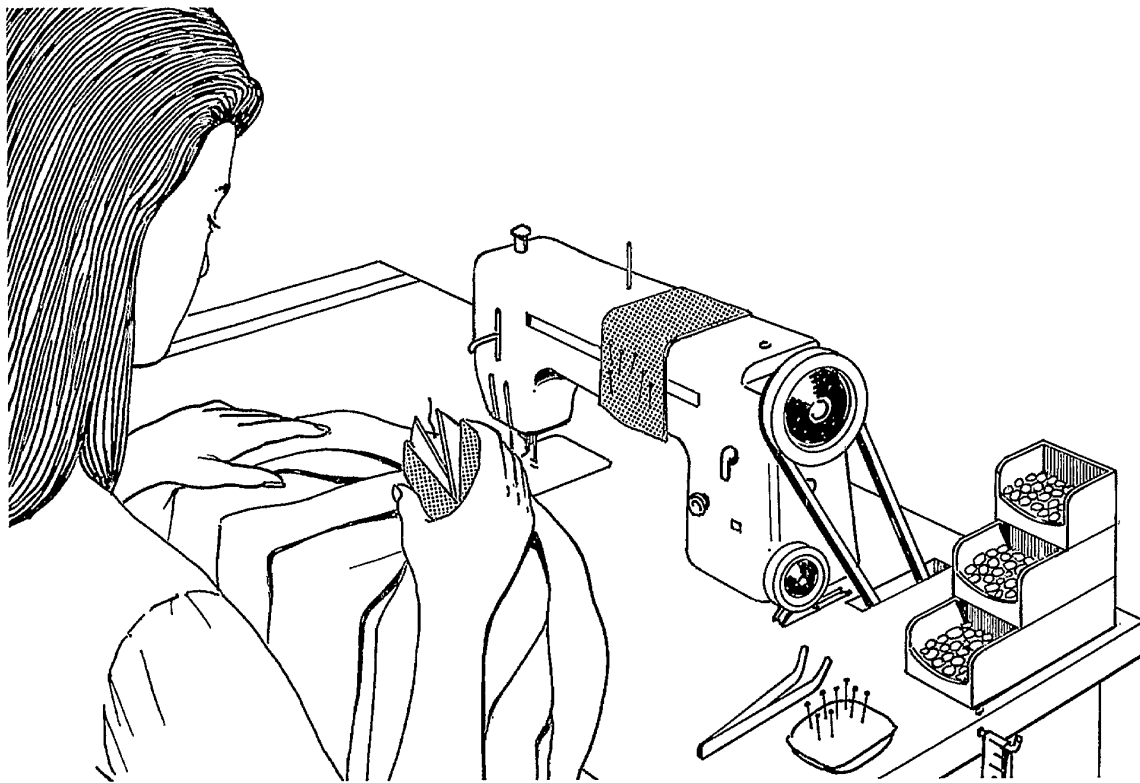

Figure 2: Nippers used for trimming off threads can be attached to the table of the sewing machine to minimize searching. Small boxes with buttons, pins on a pad or magnet, and a measuring tape help make the work more productive



Figure 3: A packing workstation with all supplies at hand

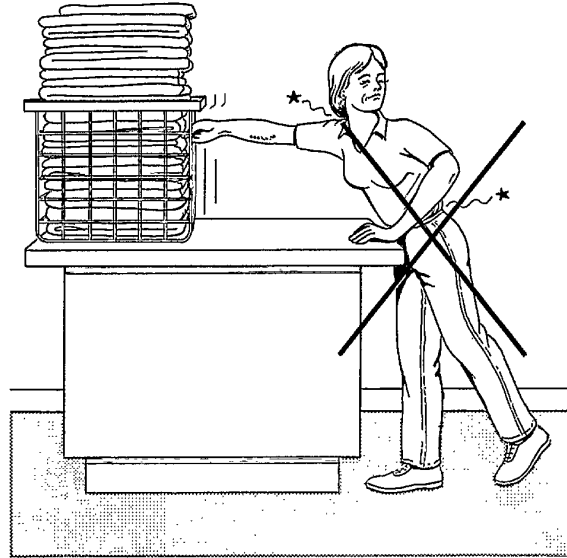

Figure 4: Difficult reaching for heavy containers should be avoided

Improve work posture for greater efficiency

Awkward bodily positions can quickly lead to fatigue and possible injury. For example, tasks necessitating raised arms tire the shoulder muscles rapidly. Operations performed while bending forward or twisting the body can easily cause back strain. As a consequence, the time it takes to complete a job increases and the worker becomes more likely to have accidents or damage goods (figures 4 and 5).

The following low-cost measures help to achieve a more comfortable and therefore more productive work position:

- provide a stable work surface where items can be firmly placed
- place materials, tools and controls where they can be reached easily by the worker without bending or twisting the body
- use platforms so that smaller workers can be at proper work height
- provide firm chairs with correct seat height and a sturdy backrest
- provide enough leg space to allow easy leg movement
- provide a footrest, particularly for seated workers.

Recommended dimensions for seated and standing work are given in figures 6 and 7.

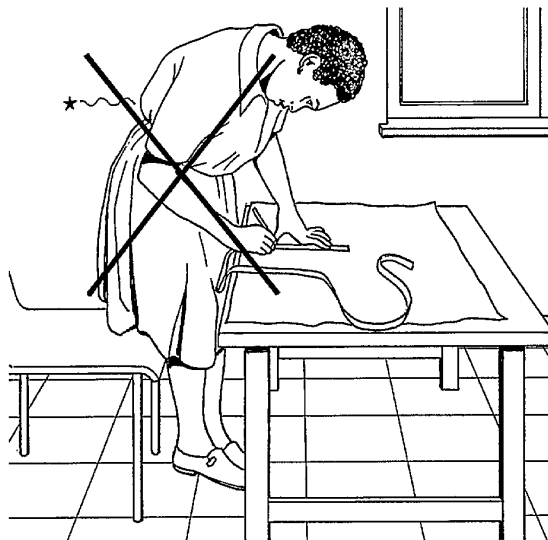

Figure 5: A working height which is too low can quickly cause low back pain problems

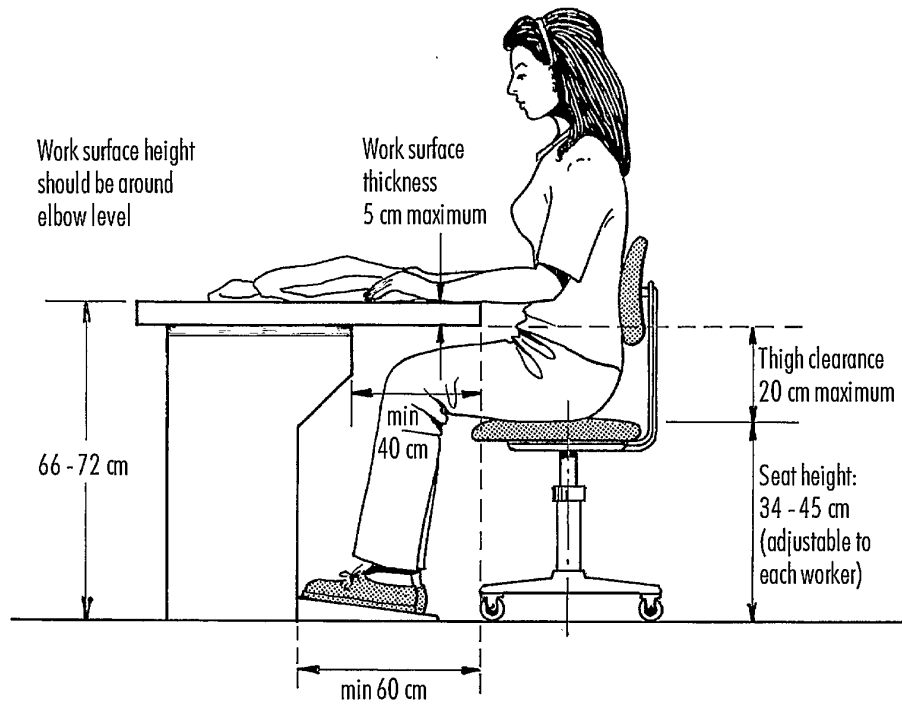

Figure 6: Recommended dimensions for most seated tasks

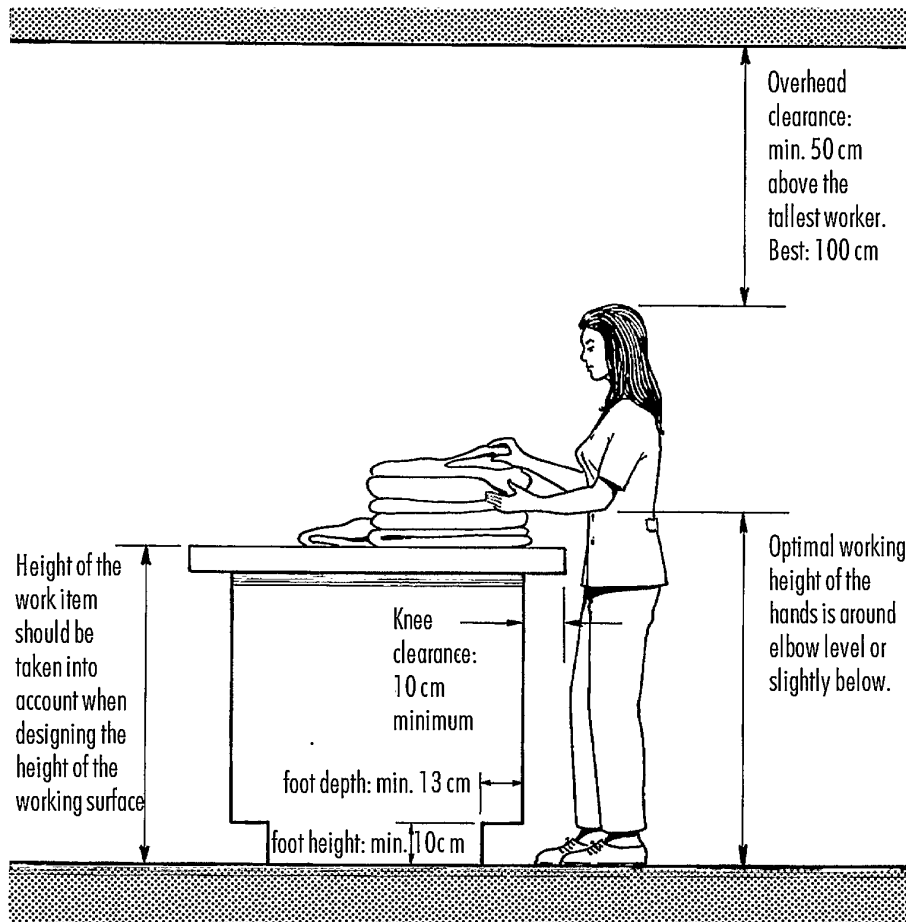

Figure 7: Recommended dimensions for most standing tasks



Figure 8: Double height work tables can be very practical for trimming and finishing tasks

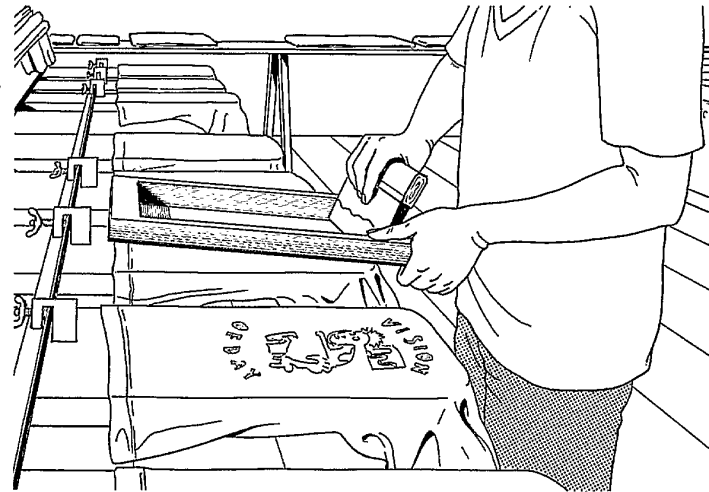

Figure 9: Silk-screening tasks are better carried out 10-20 cm below elbow height

The height of places where work is done with the hands is also an important factor. The elbow rule should be applied to determine the correct height. Most work operations are best performed around elbow level (figures 8 and 9).

The work surface or seat height may be varied by using an adjustable table or seat to suit the worker's physique. Many sewing machines are fixed in their height but they can be raised on wooden blocks to suit taller workers and the operation being performed.

Remember – make sure that the workplace is arranged to suit the physique of the worker and, in particular, that the tallest worker has enough space to move legs and body easily.

Chairs with adjustable backrests could also be provided to enable the workers, especially sewers, to lean back occasionally. Figure 10 shows the main features of a good working chair.

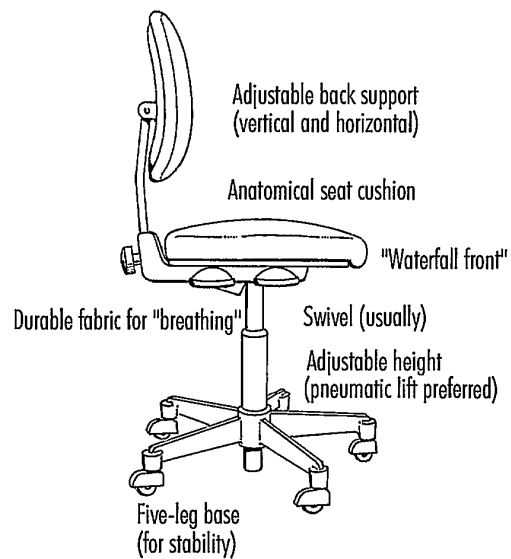

Figure 10: Adjustable chairs with a backrest should be provided for all seated workers

Vertical adjustments to make tasks more comfortable and productive can also be arranged by installing wooden platforms in front of the working table. Platforms are particularly useful in the following cases:

- short workers operating in a standing position (see figure 11)
- any worker who needs to reach a specific work point comfortably. For example, by raising the workstation a worker can reach to and from a conveyor belt without causing excessive strain on the shoulder (see figure 12).

A footrest for any seated worker, and in particular for a sewer's idle foot, can have a relaxing effect. See figure 13 for different designs.

Special consideration should be given to pregnant women: they should be assigned jobs that, where possible, will allow alternate sitting and standing; opportunities for pregnant women to stand up – for example, moving light containers to the next operation – will enable them to stretch their limbs and back. Such changes in posture, built into the work cycle, will benefit all workers.

For tasks such as preparing bundles or inspection, workers can alternate standing and sitting postures. The work table, bench and light position should be appropriately designed. Inclined work tables for inspection or marking operations are good because visibility is improved. High stools are often beneficial since they allow the workers to maintain a standing position yet place their weight on the stool (see figures 14 and 15).

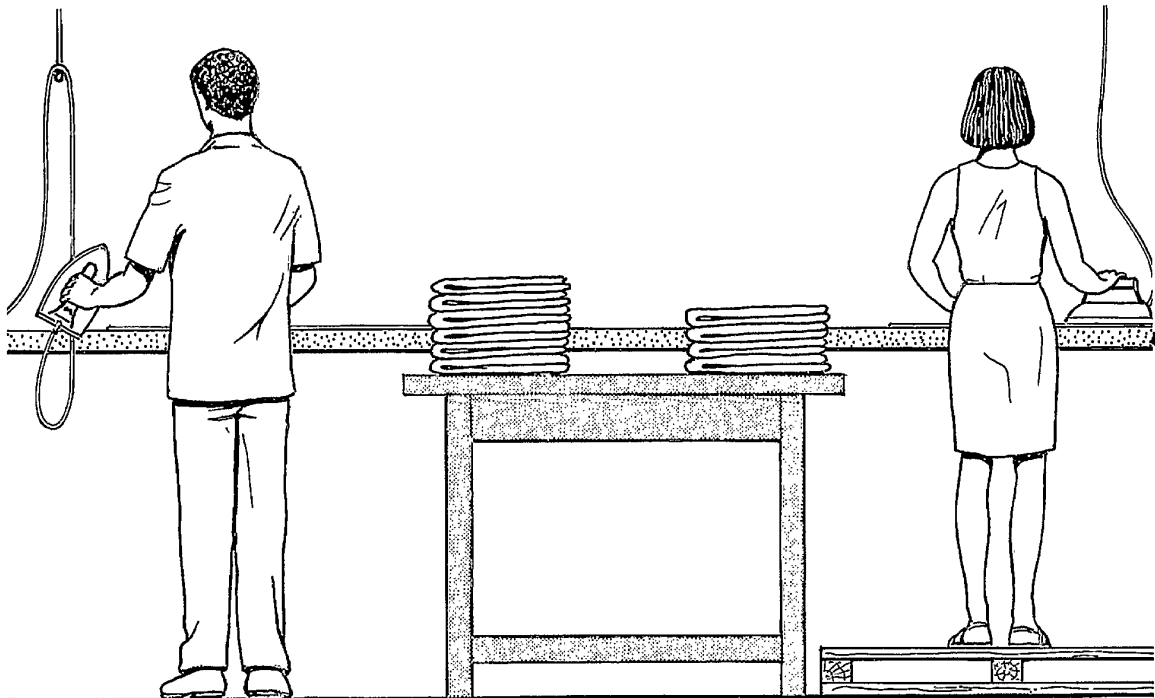

Figure 11: This ironing workstation requires a foot platform for a small worker to ensure an appropriate work height slightly below elbow height

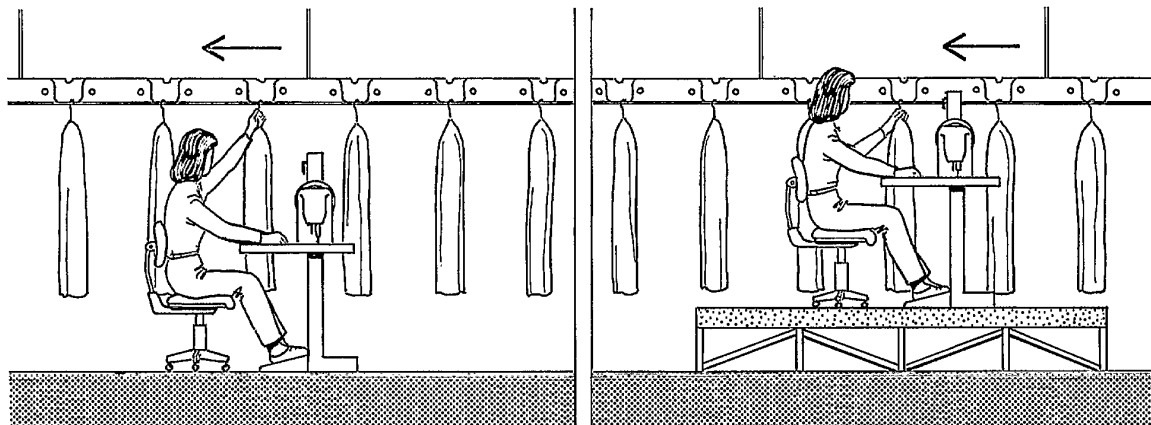

Figure 12: A too-high, uncomfortable reach for grasping hangers from a moving rail can be avoided by raising the workplace using a platform.

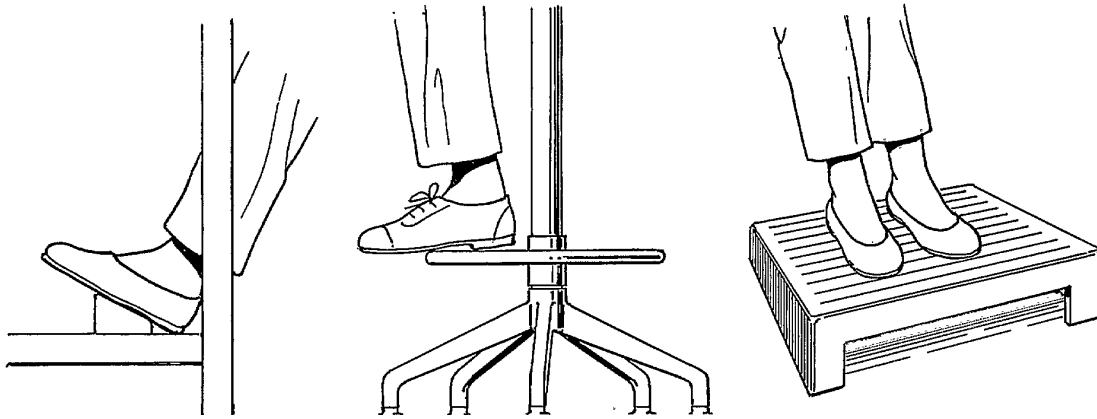

Figure 13: Different solutions for footrests: a) an integrated footrest of a work table; (b) a stool footrest; (c) a portable footrest

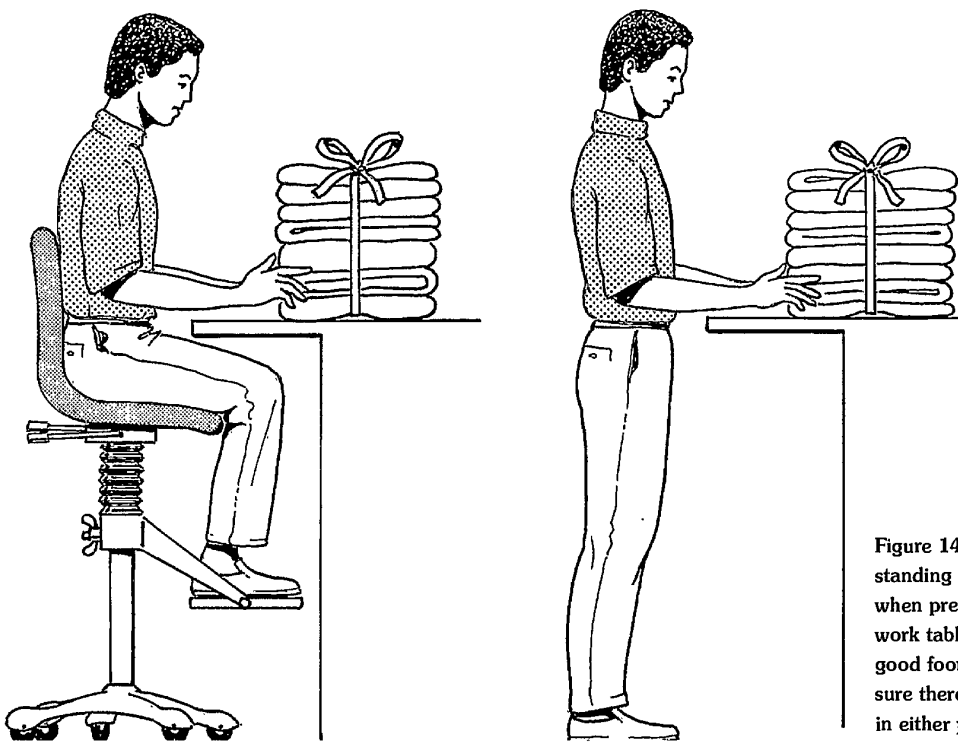

Figure 14: For alternating standing and seating postures when preparing bundles at a work table, a high stool with a good footrest is useful. Make sure there is enough leg-room in either posture

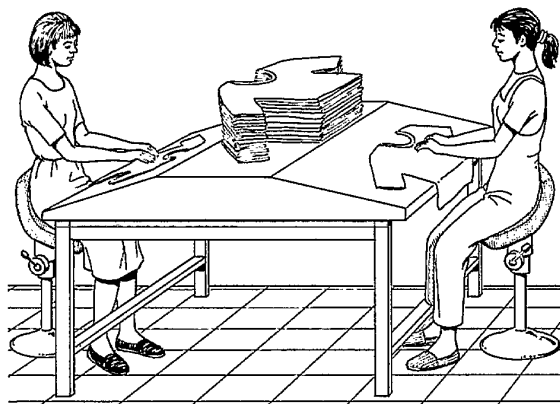

Figure 15: Provide standing workers with chairs or stools for revising and marking tasks, so that they may sit occasionally

Design your garments for easy assembly, low waste and high quality

Garment design and manufacturing is a field in which you can make a lot of improvements. It is true that many small industries manufacture standard garments for retailers under rather strict conditions and procedures. Many others, however, are producing their own designs and invariably have room for product changes. If you have that freedom, you can gain new markets and higher returns by enhancing the design of your models, increasing their quality, simplifying assembly operations and thus reducing waste.

If you want to have a higher return from your products, each should be analysed with a view to reducing manufacturing costs, improving product quality and profit margins, and consistently achieving high quality. In most cases it is possible to “engineer” or “re-engineer” the garment. To start with, select one model which you want to redesign and prepare yourself for an exciting task: to improve its design and manufacture.

The first step is to ask the following:

- is the product quality suitable for the market place?
- what is the purpose of each operation?
- can the design be changed to simplify or eliminate an operation?
- is the sequence of operations the best possible?
- why is each machine used?

The technique of engineering your garment consists of breaking down its manufacturing process into the main functional operations. Each operation is engineered or re-engineered using different work-aids to produce a design consistent with the required quality standard.

You can redesign both the garments and their manufacturing process for **easy assembly, low waste and high quality**.

The reasons why garments are redesigned for easy assembly are savings in assembly time and making the task more easy and functional. For this, you need to:

- revise and learn OR re-engineer the assembly tasks for each garment
- use interchangeable supplies
- consider the use of work-aids like jigs, guides, fixtures and attachments
- provide workers with clear written instructions and, if necessary, detailed sketches and model samples.

Workers can also help you in this process. Sit down with them and discuss how to improve your garments for easy assembly (see Chapter 10).

Environmental pollution and waste can deteriorate fabrics and other costly supplies, work-in-progress and finished garments. The more waste you create, the more time and effort you will need collecting and disposing of it. Nowadays there is an increasing industrial and social awareness of waste control.

You can control waste by:

- ensuring that patterns are correctly manufactured
- optimizing the layout of patterns before cutting operations
- ensuring the provision of standard, good quality supplies
- collecting waste the moment it is created
- installing waste containers near waste-generating workstations
- finding a secondary use for waste, e.g. training materials.

It is also likely that your workers have other good suggestions on how to control waste. Give them the opportunity to contribute their ideas.

High quality garments always deserve the attention of your customers. Manufacturing garments of quality speaks of a well organized enterprise and of committed workers. Good quality garments will increase the reputation of your enterprise and also its competitiveness. Quality products can reach international standards more easily, open new markets and this means new customers. Quality starts at cutting: good quality cutting reduces costs, throughput time, material handling and improves efficiency. The patterns used must be of good quality and shaped to represent the profile and fit the design required. For this you need to:

- create innovative designs
- if you have no good ideas, consult a local garment designer
- use good quality raw materials and supplies;
- buy good quality machinery
- introduce a preventive maintenance programme
- train workers on how to tackle production errors.

To improve garment quality try to involve your workers. Remember that they are “masters” in their workplaces. They are likely to know how to improve assembly tasks, save time, avoid waste, improve appearance and increase quality. Why not offer them a chance to become involved? Organize a joint discussion on suggested improvements.

Use guides to check measurements of pieces and garments

Checking the size of ply pieces being produced would be easier with the use of measuring guides attached to a work table. A measuring tape with marks according to the

measurement of the piece to be checked can serve as a guide. With this low-cost aid, the worker would just have to lay the piece flat on the table and compare its size against the guide's length (figure 16).

Size control can be done more efficiently if patterns, dummies, boards or frames are used. Patterns made of scrap cardboard should be avoided. Soft cardboard wears very quickly with use and the pattern profile changes, thereby producing incorrect shapes and measures and increasing the amount of sewing time necessary to fit panels. Special card, plastic or resin board should be used for patterns. Identify each pattern with its garment name and size to avoid mistakes.

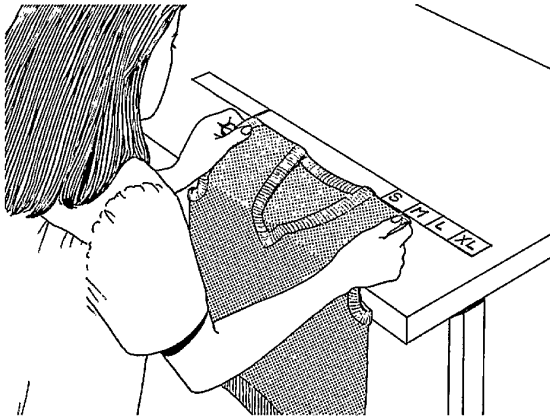

Figure 16: A measuring tape with regular marks according to standard sizes and fixed to the work table helps for checking garment sizes

Use jigs and other devices to save time and effort

All operations require a degree of material handling at the needle point. There are a number of methods and techniques that can be used such as jigs (manual and automatic), fixed and adjustable guides and work aids to replace the use of fingers during the sewing cycle. All these measures allow de-skilling of the operation and contribute to quality and productivity. Other examples of work aids are:

- the knee-lifter
- feeders, cramps or other fixtures to hold work in place
- the use of gravity
- minimizing vertical movement when work items are moved from one place to another.

One of the basic principles of motion economy is to use both hands simultaneously and productively. In many cases, work can be done more skilfully and efficiently when both hands are free and not controlling machine levers, etc., which other parts of the body can do as

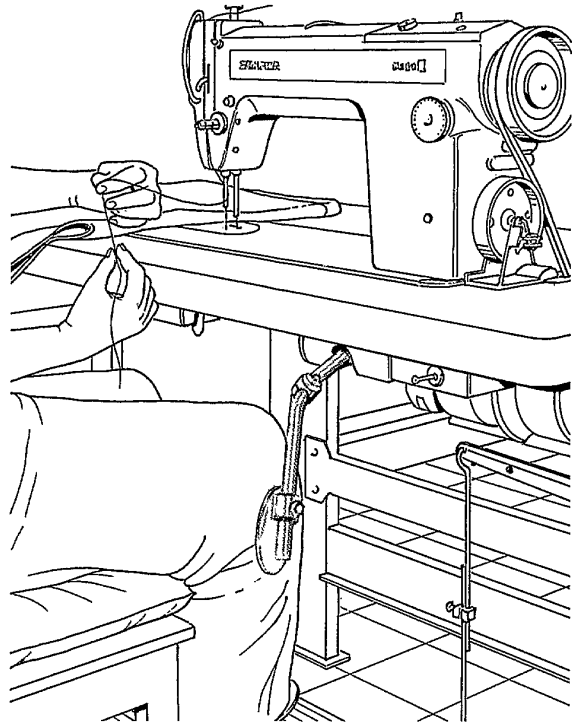

Figure 17: Using a knee-lifter for operating the foot presser allows a more precise positioning of the garment on the sewing point

effectively. Take for example the operation of the presser foot: by transferring its control from hand to knee through the knee-lifter, both the worker's hands are freed and the positioning of the garment on the sewing point is more accurate (figure 17).

In the cutting room metal cramps can be used for holding fabric during cutting tasks (figure 18).

Small or very light pieces of material can be held in place on the machine table using elastic wrapped around the sewing table. Similarly, strips of elastic can be measured

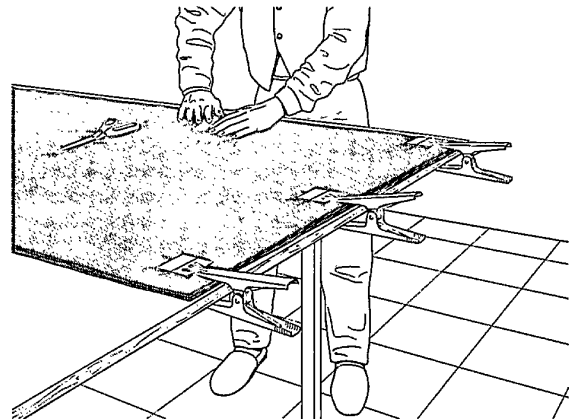

Figure 18: Low-cost metal cramps keep fabrics firm and stable, allowing easier and faster cutting operations

and cut more easily with the use of a measuring fixture attached to the work table. This is shown in figure 19.

When workers are being trained for manufacturing new products there is usually a high waste of material and therefore lost production. To minimize losses and ensure quality, it is advisable to use jigs even for small production runs during training.

Here are some examples of today's jig technology for improving sewing tasks. When attaching a tape to a skirt top, uneven stitching can be avoided by using a tube foot and a tape roll stand as feeders (figure 20). A sewing machine workstation with a special feeder and with a series of belts allows standard sewing operations (figure 21). The inner track of the stitching jig defines the stitching path (and cloth trimming) while the drive wheel engages the outer track of the jig (figure 22).

Simple components like cuffs and pocket flaps are most efficiently produced using double jigs. The finished component is loaded before the jig comes to rest. As soon as the jig stops, the operator can load the new cloth pieces and initiate the automatic sewing cycle (figure 23).

Figure 24 shows an engineered workplace layout, using large jigs for sewing bodies of a coat. While the operator loads the fabric pieces into one stitching jig, the jig machine automatically sews and turns the previously loaded pieces.

Outputs can be placed on small stacking tiered tables, frames or trays, sited by the side of the sewing machine. Some machines have automatic stacking frames. Appropriate containers should be used as shown in Chapter 2 (figure 25).

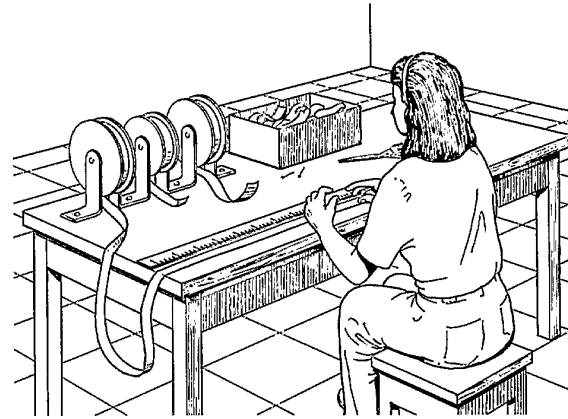

Figure 19: Measuring and cutting elastics, lace and other material can be made easier by using fixtures and guides attached to a work table

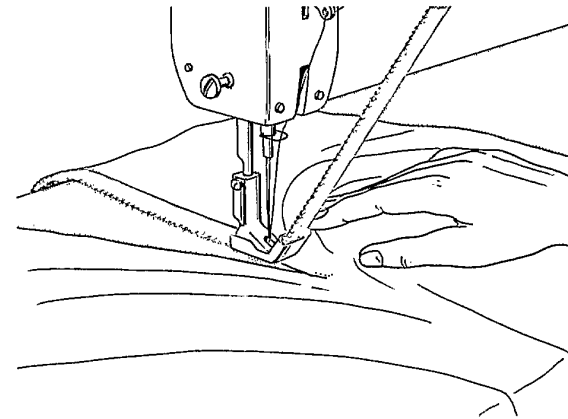

Figure 20: Using a tube foot makes stitching tape to skirts an easy, fast and good quality task

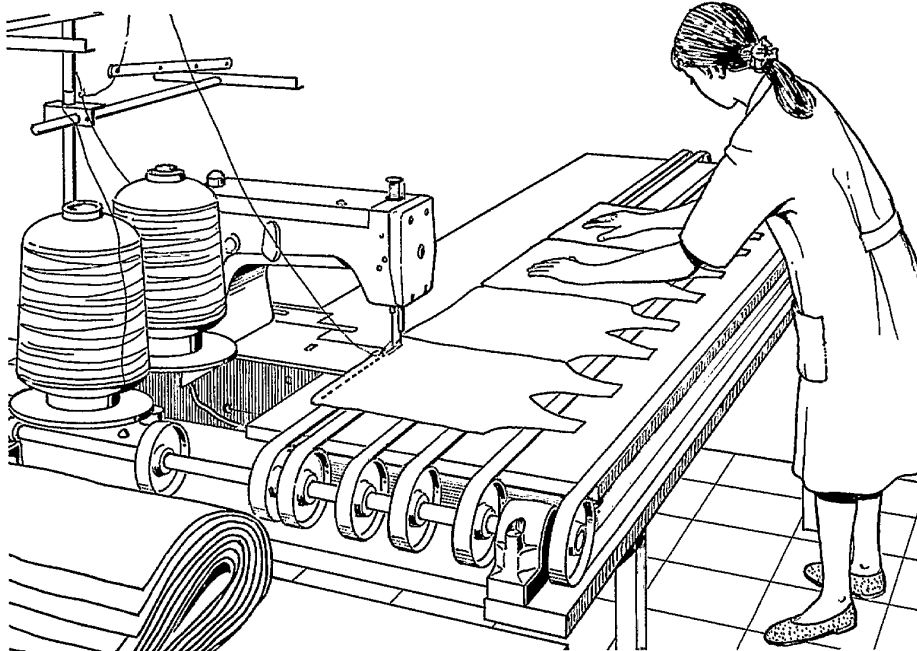

Figure 21: This belt-operated fixture adapted to a table ensures a standard quality and fast sewing operations

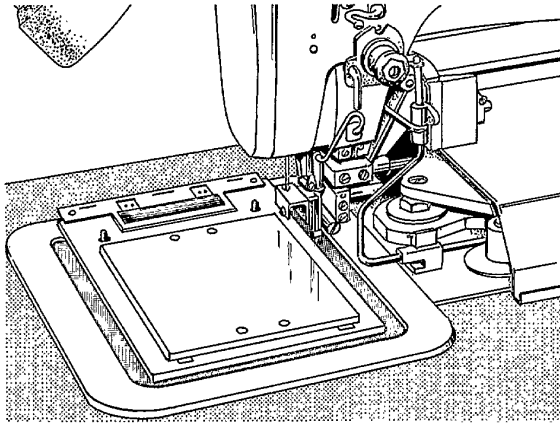

Figure 22: Shirt pockets can easily be stitched using a light weight jig

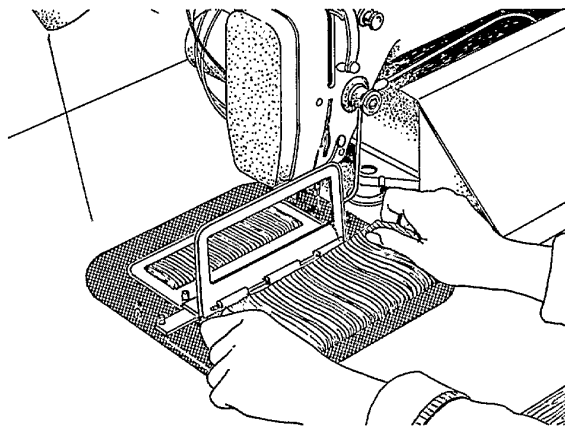

Figure 23: Pocket flaps can also be stitched using similar jigs



Figure 24: Bodies of coats can be sewed using larger jigs in automated jig machines

A litter bag attached to the work table of every sewing machine can help maintain a clean and neat workstation. This is shown in figure 26. Containers for productive outputs and for litter should be different (i.e. in colour and size) and installed in different places.

Trimming and quality control tasks can be improved by using appropriate adjustable frames to hold garments whilst being inspected (figure 27).

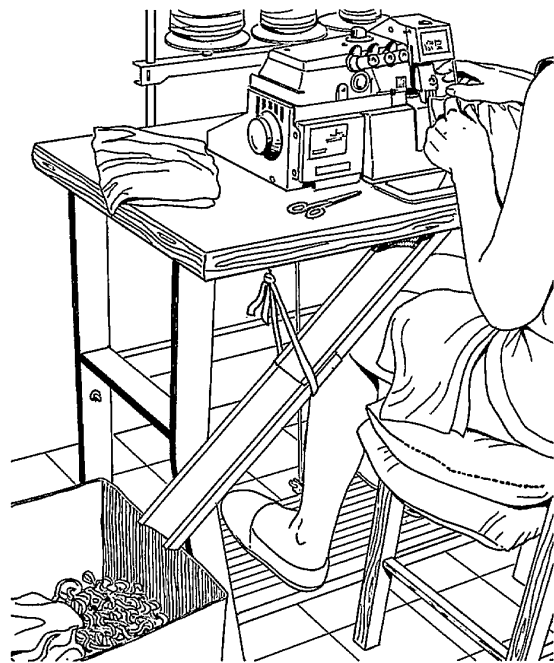

Figure 25: Useless outputs can be collected directly into a litter box through a hole in the table, connected to an adjustable slide

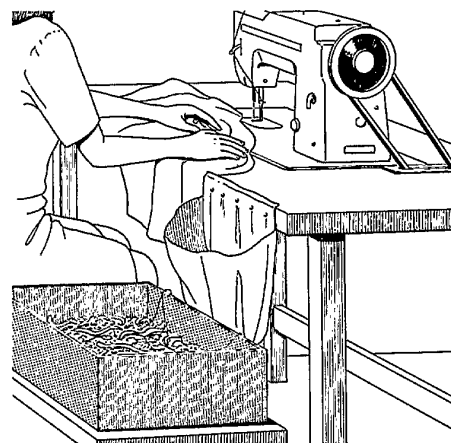

Figure 26: To keep sewing workstations tidy, litter bags for ends of threads and trimmings can be placed at the side of the work table

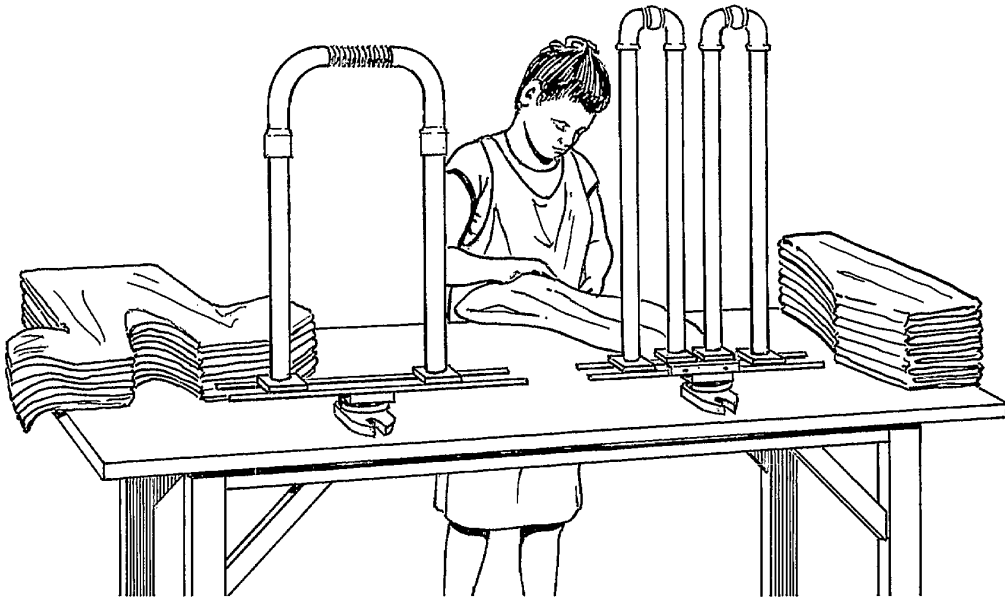

Figure 27: These two lightweight rotatory fixtures ensure a quick and easy mounting of (a) T-shirts and (b) trousers for quality control tasks

Improve displays and controls to minimize mistakes

Products and machines are often damaged by mistake and accidents are often ascribed to human mistakes. An effective way to avoid such mistakes is to ensure that each worker can see and identify clearly displays and controls that she/he is operating. The following points are important:

- keep visual displays, knobs, switches, pedals, etc., which have to be seen, touched or controlled, within easy sight and easy reach of the worker
- make displays and controls easily distinguishable; and
- use good lighting (see further information on lighting in Chapter 5).

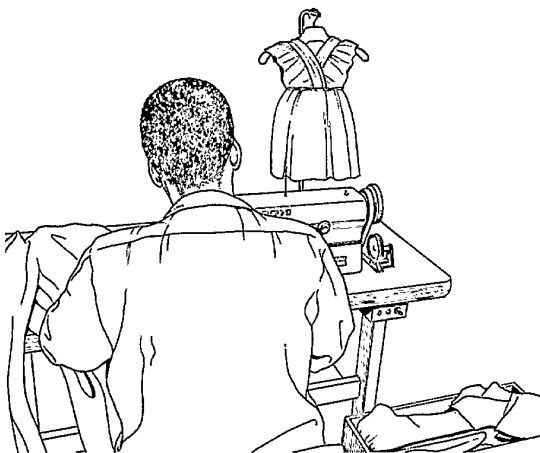

Figure 28: A sample of the finished product being worked on prevents mistakes and helps ensure the final quality of the product

Good location of frequently used displays is important. For example, a sample of the finished product being sewn by a line could be displayed in a strategic place within direct view of all workers so they can visualize the use of the parts they are sewing. Figure 28 shows a movable display rack that can be used for this purpose. A sample of smaller finished pieces or products can be displayed on top of the workstation or fixed to the column holding bobbins. This is a basic condition for good work and for avoiding mistakes and unnecessary rework.

Display or control *distinguishability* is as important as their location. For example, a stop switch should be clearly distinguishable from a start switch; an emergency signal should be different (e.g. red) from a normal condition signal (e.g. green). This difference can be enhanced by:

- using different sizes, shapes or colours for different kinds of switches or signals (figures 29, 30 and 31)
- attaching clearly visible, simply worded labels to each control or display
- grouping mutually related displays and controls using the same on-off directions
- placing displays and controls according to easy-to-identify sequences.

For effective displays, it is important that the function of each signal, dial, gauge or other visual device is clearly understood. For example, an emergency signal should be outstanding in its position and size and should be coloured red. Controls and displays (switches and gauges, etc.) should be logically placed in relation to the machines to which they apply.

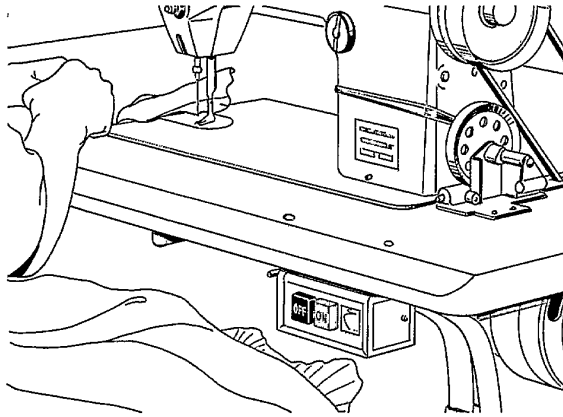

Figure 29: ON (red) – OFF (black) switches should be at hand and easily recognizable

When operating some controls, workers are sometimes confused about the control response. In sewing and other machines this may happen with on-off switches or with controls requiring manual adjustment. The direction of their movement (up-down; left-right; clockwise-anti-clockwise; push-pull or other) must be easily understood and should be properly labelled.

To avoid mistakes and accidents, all controls and displays of similar machines should keep the same configuration, including position, size, colour, function and movement. This will reduce the worker's learning time and will improve productivity.

Remember – ALL switches and buttons on programmable machines that are not in use, should be taped up. This will avoid misuse and involuntary operation which may require an experienced technician to reset the machine.

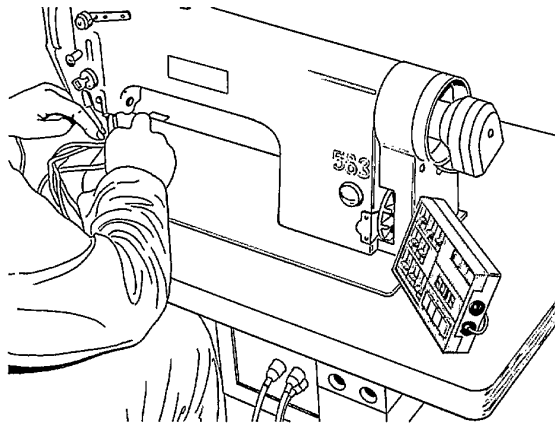

Figure 30: This small control panel with a touch-sensitive display can be placed in different positions for easy use

Summary

Rules for design of efficient, comfortable workstations and good quality products

1. Position materials, tools and controls within easy reach.
2. Improve work posture for greater efficiency.
3. Design your garments for easy assembly, low waste and high quality.
4. Use guides to easily check measurements of pieces and garments.
5. Use jigs and other devices to save time and effort.
6. Improve displays and controls to minimize mistakes.

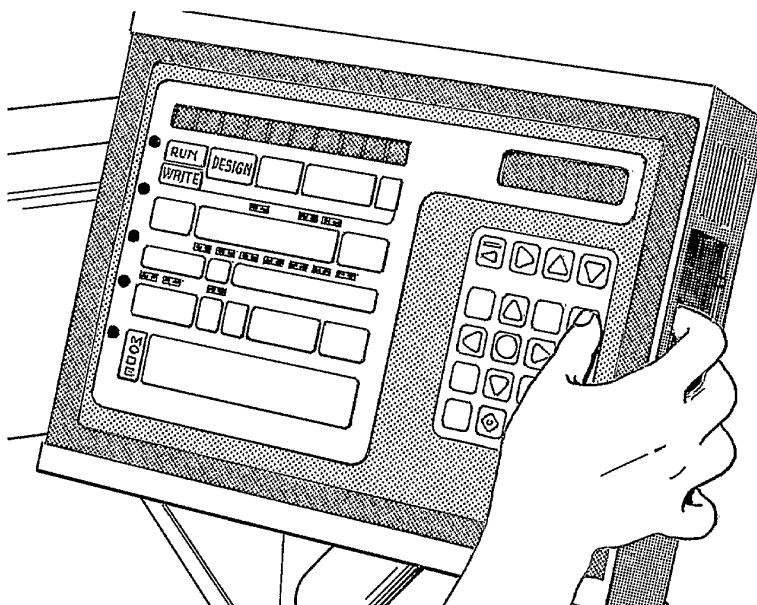

Figure 31: The control panel of this programmable embroidery machine groups the controls and displays according to different functions and programmes. Control and display labels should be written in local language to avoid misuse and mistakes

4

Productive machine safety, maintenance and environmental control

Machines are essential to modern production. However, along with increased productivity, they have brought hazards into the workplace. Proper control of machine hazards has traditionally been seen as costly and a constraint on productivity. In general, the garment manufacturing industry is considered to be less dangerous than other industrial sectors and, therefore, safety policy is a low priority in many enterprises. For example, it has been observed that some workers remove guards protecting belts from sewing machines, and manual cutting machines are operated with naked hands.

Machine breakdown is a common cause of production delay affecting delivery schedules. Considering the importance of meeting delivery dates, a competitive enterprise cannot afford penalties for delay due to machine breakdown. Thus, proper maintenance of machines to prolong their economic life, reduce breakdowns, prevent defective outputs and ensure safe operation should be given more importance.

Protecting workers against pollution from the frequent use of solvents for cleaning and the existence of cotton or other fibres in the environment should also be taken into consideration.

Maintenance and safety measures to eliminate these hazards and increase machine productivity, together with low-cost techniques for environmental control, are discussed below.

Give your machines a productivity check

Walk through the plant and take note of the following:

- are there any delays or bottlenecks caused by specific machines?
- do any machines operate slowly because of wear and tear?

- is there fear or hesitation among workers caused by unsafe machines or processes?
- are there situations where machine guards have been altered, removed or destroyed?
- have any machines been out of action in the past week/month, due to breakdown?

If you have answered yes to any of the above questions, the first part of this chapter will assist you in dealing with the problems of machine productivity and safety. Figure 1 provides a good example of the results of a machine safety and productivity check up.

Machine safety

All machines in the garment industry can be potentially dangerous when they are misused. You can eliminate, control or minimize the risk of accidents by installing guards on unprotected machinery, e.g., bandknives in the cutting room. Workers should wear personal protective equipment and ALL cutters should wear chain-mail gloves.

Sewing machines are relatively safe provided the correct training on how to use them has been carried out. Irons, especially steam irons, can cause serious steam burns if not used correctly. The most common accidents in the garment industry are:

- cut fingers in the cutting room
- a needle in the finger
- burns from irons.

There may be other hazards as well in the workshop, such as unprotected belts or pedals, unused displays or controls, hot parts, contaminated vapours, uncovered cans with solvents evaporating, naked electric wiring, etc. ALL hazards, wherever possible, should be removed. If you cannot eliminate a hazard, try to control it. The next step is to place a guard around it. However, guards must be very carefully designed or they may get in the way. Figure 2 shows a guard integrated in the design of the equipment.

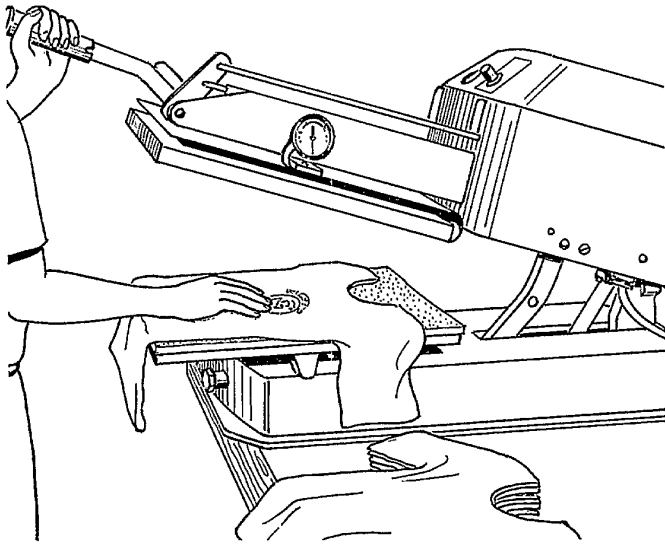
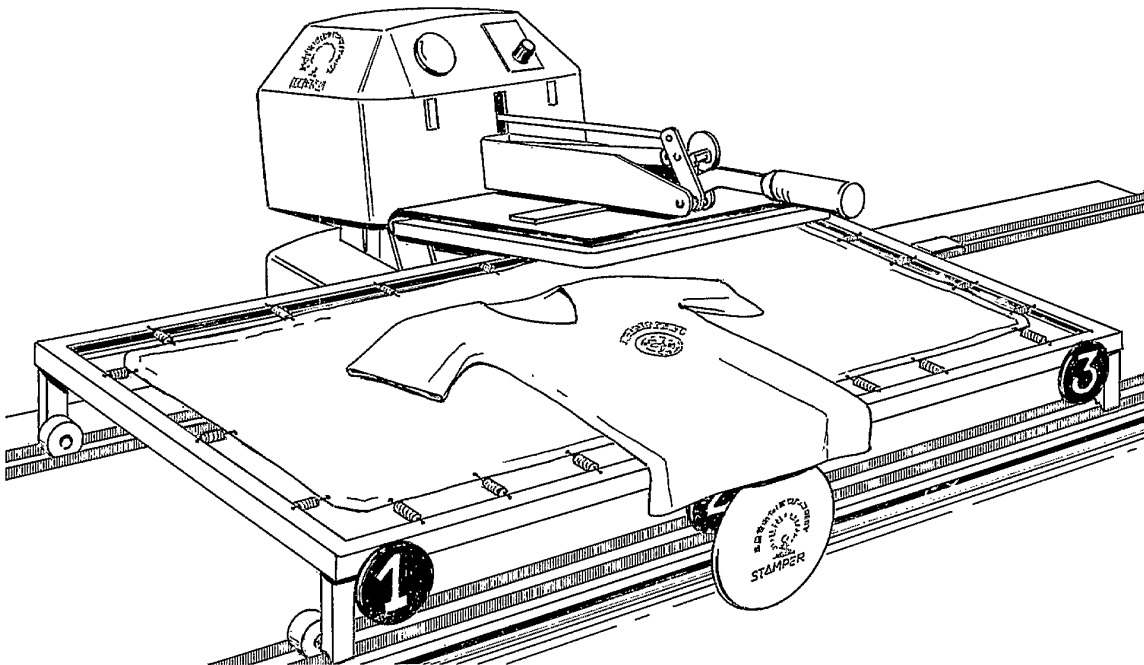
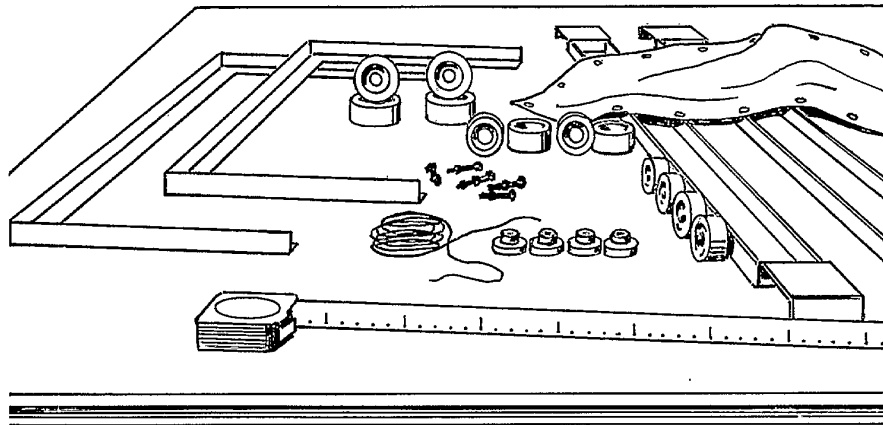

Figure 1

(a) This transfer-stamping workstation with exposed heating elements was slow to operate
 (b) A few spare low-cost materials were used for improvement
 (c) A movable table was built allowing faster operation of the machine without the risk of touching the heated parts. After improvement, there was no idle time and productivity increased by 200 per cent



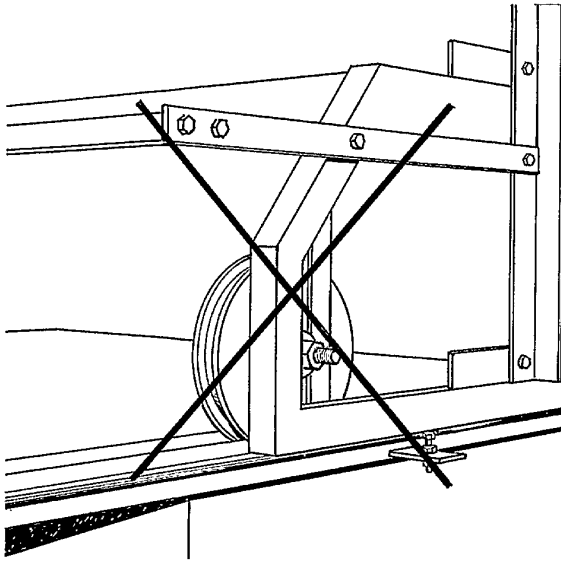

Figure 2 (a) (above): This low cost guard integrated to the frame of a cloth spreader machine protects workers' hands from the nip point

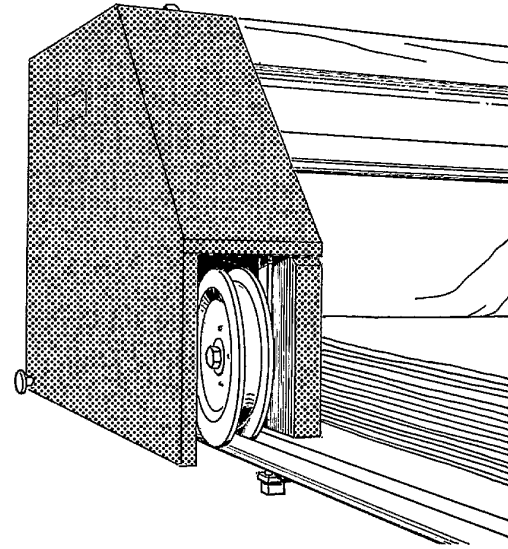
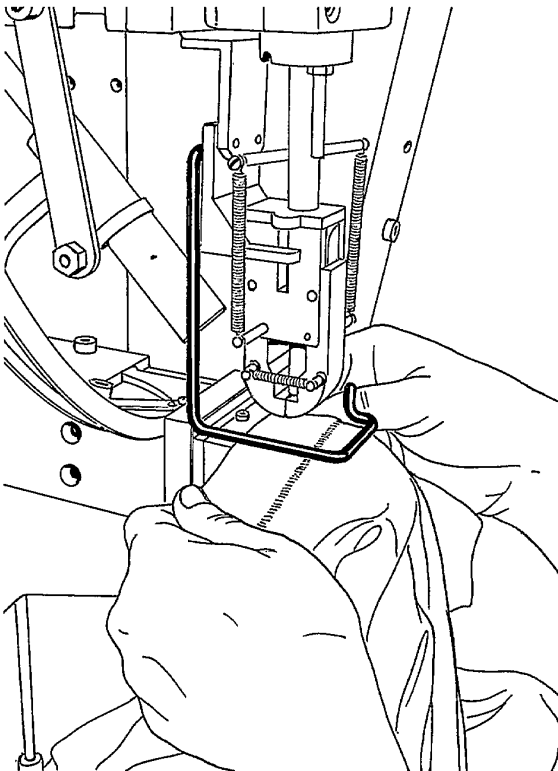

Figure 2 (b) (left): The metal rod in this snap fastener machine, which is placed around the working point, prevents both thumbs entering the danger area



The most dangerous equipment in the garment industry is the bandknife and straight knife. Although a chain-mail glove slows the cutting process by up to 5 per cent, it ensures complete safety to the worker. It also increases cutting accuracy because the wearer can cut closer to the line, thereby producing less waste and more accurate garment profiles.

When you consider that garment blocks are cut up to 50 ply deep, this slower cutting rate is more than compensated by the quality produced with fewer sewing problems and misshaped garments. Figures 3 (a) (b) and (c) show several manual cutters in operation and the safe use of a chain-mail glove with one of them.

Remember - In taking preventive and protective measures, risks should be assessed and dealt with in the following order of priority:

- *eliminate the risk*
- *control the risk at source (e.g. by guards)*
- *minimize the risk by devising safe work procedures*
- *in so far as the risk remains, ensure the use of personal protective equipment.*

Purchase safe machines

Manufacturers normally produce safe machines and equipment, with built-in guards and safety features. When a new machine is ordered, care should be taken to check that the machine is equipped with guards and that all safety features are in order.

Special care should be taken when buying second-hand machines and equipment as guards might have been dismantled or simply not included.

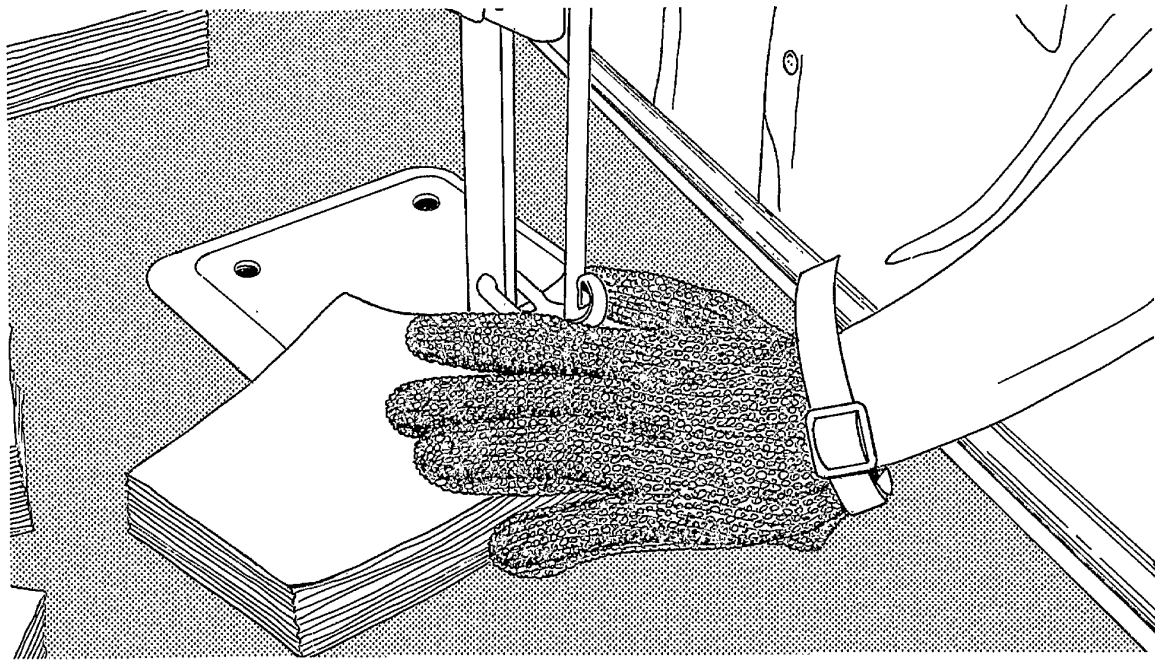
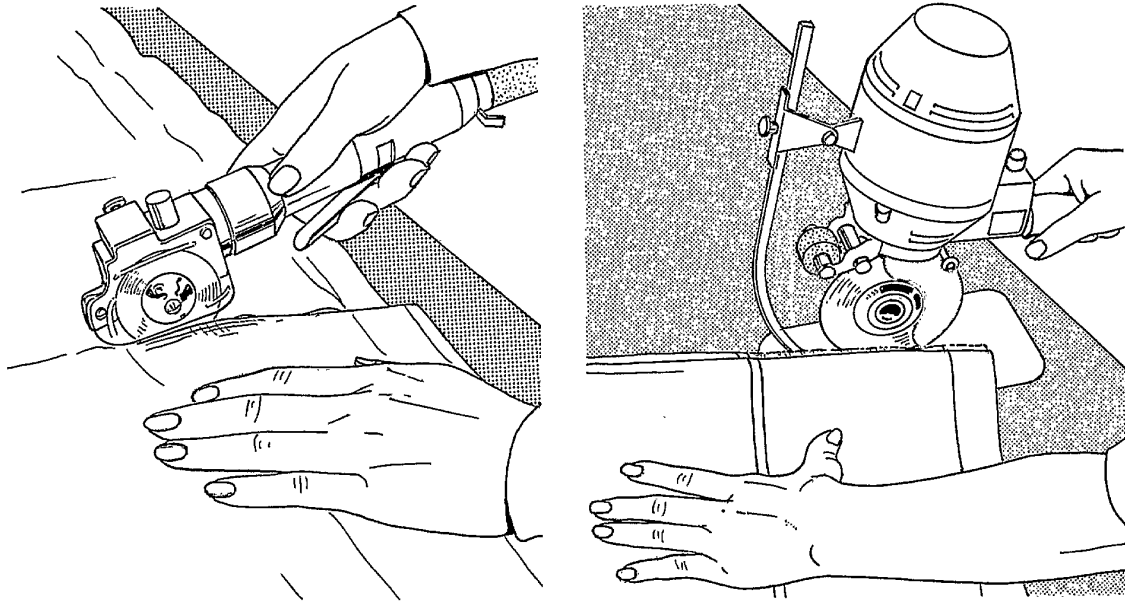

Figure 3 (a) (b) and (c): Most electric or pressurized air operated cutting machines have appropriate guards. It is, however, wise to always wear a protective glove. This chain-mail (metal mesh) glove allows safe operation when cutting small garment parts

If you have a special need, design your own equipment and ask a local manufacturer to build it; be sure to include appropriate guards on all potential “nipping” points.

Make sure that you have an operation manual at hand for each machine and that any operating instructions and labels are in the local language and readily available to the workers.

Maintain machines properly

A poorly maintained machine can be inefficient, if not dangerous. It will also have frequent breakdowns and quality problems. Proper maintenance is *not* lost production time; it is an investment for higher productivity and lower repair costs. Yet in many companies, machines are maintained only when they break down. This is due to a number of reasons:

- machines are owned by the contractors or they are leased
- no maintenance personnel are available
- no time to maintain machines is allocated under production time
- there is a strong belief that maintenance means cost
- some machines are not easy to maintain.

Machine down-time affects production and causes delays. Defects are also produced causing quality and productivity problems. Machine maintenance should, therefore, be planned and coordinated with supervisors and workers. Workers should be involved in machine maintenance and should be supplied with a basic tool kit to include tweezers, small screwdriver, machine brush, oil can and cloth wipes. One of the basic training skills is to train workers to do routine machine maintenance such as:

- changing broken needles
- bobbin changes
- machine cleaning
- adjusting thread tensions.

All other machine maintenance should be carried out by qualified mechanics or technician.

Some activities need to be carried out weekly, others every two weeks and some on a monthly basis. Figure 4 shows sewing machines turned upside down for regular maintenance.

Teach workers to troubleshoot common machine problems

In many cases machine problems are due to the worker not having received correct training in basic machine maintenance. This causes problems which have to be rectified by a qualified mechanic/technician. All garment enterprises suffer from such problems to varying degrees. Some common causes are:

- incorrect needles
- incorrect machine settings for the fabric
- inexperienced workers
- inexperienced mechanics/technicians
- fabric finishes.

On-the-job training sessions may be organized for beginners as part of their training period. Enlist the help of senior operators with teaching skills. Group work can provide good opportunities for these training sessions. Sessions should include acquiring the basic sewing skills and troubleshooting sewing problems. The identification of causes of common problems encountered with zigzag and overlock sewing machines discussed below should also be part of the training.

Figure 4: Maintenance tasks help prevent the unexpected breakdown of machines and other equipment. Trained workers can undertake simple maintenance tasks

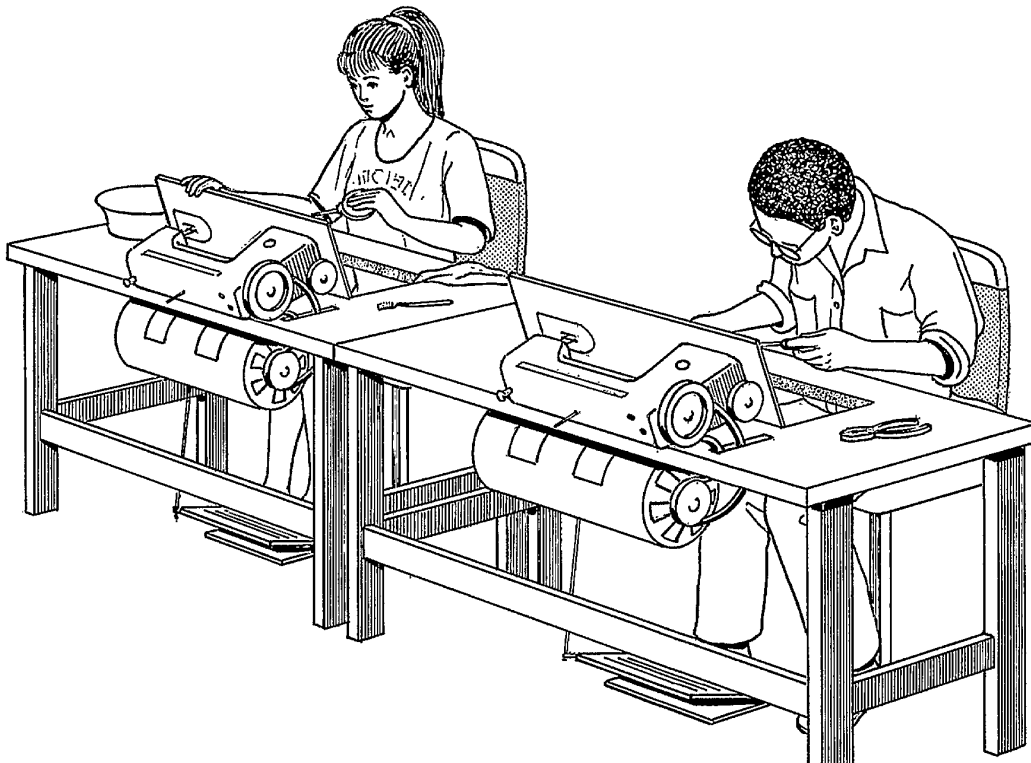

A. STRAIGHT / ZIGZAG SEWING

Problem

Cause

1. The needle thread is cut.
 - a) The needle thread is not threaded properly.
 - b) The needle thread tension is too tight.
 - c) The needle is bent or blunted.
 - d) The needle is incorrectly inserted.
 - e) The fabric is not being drawn to the rear when sewing is finished.
 - f) The thread is either too fine or too heavy for the needle.
 - g) Both threads are pulled back under the presser foot.

2. The bobbin thread breaks.
 - a) The bobbin thread is not placed properly in the bobbin holder.
 - b) Lint has collected in the bobbin holder and/or tension spring.
 - c) The bobbin does not rotate smoothly.

3. The needle breaks.
 - a) The needle is incorrectly inserted.
 - b) The needle is bent or blunted.
 - c) The needle clamp screw is loose.
 - d) The needle thread tension is too tight.
 - e) The fabric is not drawn to the rear when sewing is finished.
 - f) The needle is too fine for the fabric being sewn.
 - g) The pattern selector dial has been turned while the needle was in the fabric.
 - h) Wrong size needle.

4. Skipped stitches.
 - a) The needle is incorrectly inserted.
 - b) The needle is bent or blunted.
 - c) The needle and/or the thread are not suitable for the fabric being sewn.
 - d) The needle is not threaded properly.
 - e) A BLUE TIPPED needle is not being used for sewing stretch, very fine or synthetics fabrics.

5. Seam puckering.
 - a) The needle thread tension is too tight.
 - b) The needle and/or bobbin are not threaded properly.
 - c) The needle is too heavy for the fabric being sewn.
 - d) The stitches are too coarse for the fabric being sewn.

6. Stitches loop behind the fabric.
 - a) The needle thread tension is too loose.
 - b) The needle is either too heavy or too fine for the thread.

7. The fabric is not being fed smoothly.
 - a) The feed-dog is packed with lint.
 - b) The stitches are too fine.
 - c) The fabric was not fed correctly at the beginning of sewing.
 - d) The feed-dog has dropped.

- | | |
|----------------------------------|--|
| 8. The machine does not operate. | <ul style="list-style-type: none"> a) The machine has not been plugged in firmly. b) Thread is jammed in the hook mechanism. c) The pattern selector dial has been set at "overlock sewing". d) The bobbin winder spindle has been pushed to the winding position. |
| 9. The machine is noisy. | <ul style="list-style-type: none"> a) The machine is in need of oil. b) Dust and lint have collected in the hook mechanism. c) The feed-dog is packed with lint. |

B. OVERLOCK SEWING

Problem	Cause
1. The cloth is not being fed smoothly.	<ul style="list-style-type: none"> a) The feed-dog is packed with lint. b) The presser foot has been raised.
2. The needle breaks.	<ul style="list-style-type: none"> a) The needle was incorrectly inserted. b) The needle was bent or blunted. c) The fabric was forcibly pulled. d) The thread was jamming with spool spin.
3. The needle and/or looper thread break.	<ul style="list-style-type: none"> a) The machine is incorrectly threaded. b) The needle or the looper thread tension is too tight. c) The needle is incorrectly inserted. d) The needle is bent or blunted. e) The thread is jamming with spool spin.
4. Skipped stitches.	<ul style="list-style-type: none"> a) The needle is incorrectly inserted. b) The needle is bent or blunted. c) The machine is not correctly threaded.
5. The seam is not sewn neatly.	<ul style="list-style-type: none"> a) The needle and/or looper thread tensions are not correctly adjusted. b) The machine is not correctly threaded. c) The needle and/or the thread are not suitable for the fabric being sewn.
6. Seam puckering.	<ul style="list-style-type: none"> a) The stitch selector dial has been set at "Straight Zigzag Stitch". b) The bobbin winder spindle has been pressed to the winding position.

You may prepare tables similar to these listing the most common problems and causes encountered by your workers. Tables for other workstations, i.e. cutting, ironing and packing, can also be prepared. These tables should be available to workers to troubleshoot the most common problems.

Environmental control measures

Hazardous substances in one form or another can be found in almost all small and medium-sized enterprises. The garments industry generates a lot of dust from fabrics being cut and sewn. Some fabrics release chemicals which saturate the air causing difficulties in breathing and eye irritation. Solvents used for cleaning fabrics and garments may cause fatigue, headache and dizziness. Dust and solvents, when breathed, can lead to lung diseases and are very dangerous. Not only will this affect the well-being of your workers, it will also result in a reduction of productivity and product quality, increased absenteeism and turnover of staff.

High levels of dust interfere with efficient production and require cleaning operations that may spoil materials and finished products. Improved conditions usually mean increased output, higher productivity and quality.

There are simple and inexpensive ways to control most of the environmental problems. Improvements often result in cost savings, productivity benefits and increased safety of workers. The following rules provide a series of low-cost measures for sound environmental control.

Clean regularly and properly – do not spread dust

Dust originates from fabrics and threads, from cutting and sewing to packing operations. Thus, it is very common to see small clothing enterprises with ceilings and walls full of dusty cobwebs. Even machines which are not regularly cleaned could be full of dust which may cause them to break down.

Dust increases wear and tear on machinery, necessitating more maintenance. It also negatively affects the quality of raw materials and finished products. Dust entering the respiratory system can damage the worker's lungs. Some dust can also cause allergies.

Dust should be removed regularly and eliminated from the source. More comprehensive cleaning should be carried out as often as necessary. This cleaning should also include walls, ceilings, storage racks and other areas where dust accumulates. Dust on windows, walls and lamps will significantly reduce the lighting in the workplace.

One low-cost cleaning method is sweeping the floor carefully with an appropriate broom and accompanying dust pan to prevent dust from spreading. Spraying water on the floor before sweeping will avoid dust remaining airborne. When dust is moistened it can be easily removed with a broom (figure 5). More effective methods of controlling dust include using a vacuum cleaner or a wet mop (figure 6).



Figure 5: It is good practice to clean the floor at least once a day. Spraying water on the floor before brushing prevents spreading dust

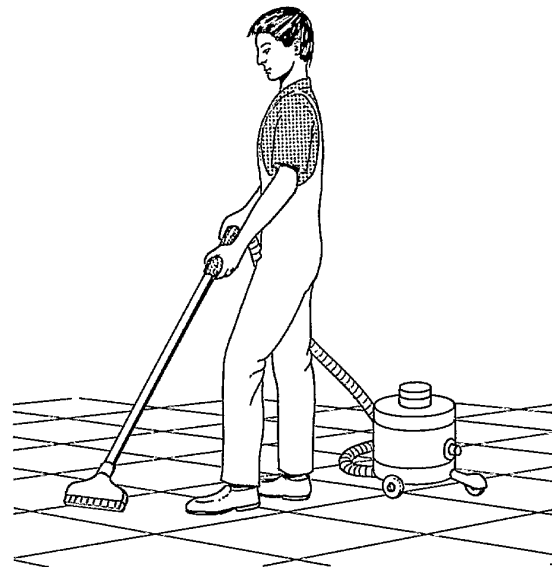
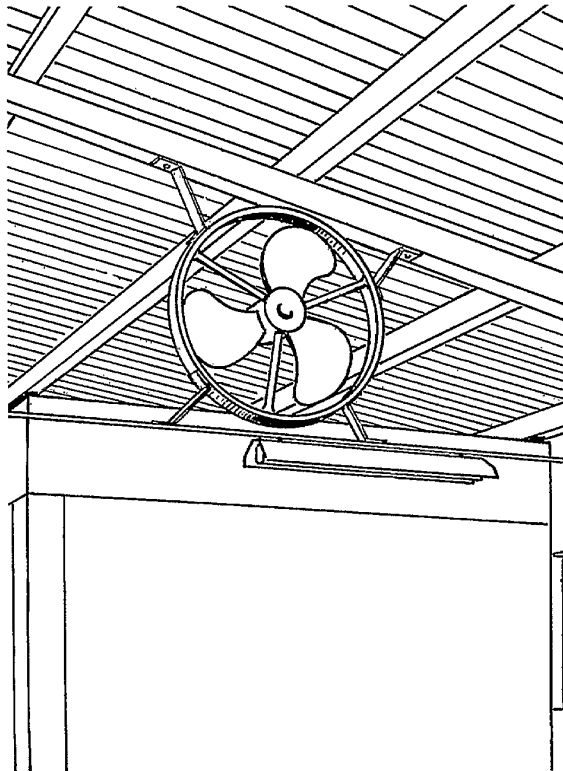

Figure 6: Vacuum cleaners are recommended for cleaning floors, walls, workstations, windows and ceilings

Warning: Do not blow dust away. Dust containing very small particles does not fall immediately to the floor after being raised by sweeping and blowing. A 0.001 mm particle will only fall 1 m in 3.5 hours in static air. This means that a particle remains airborne most of the working day and can be inhaled. Frequently, dust cannot be seen in the air, but the next day it can be found covering the floor, work tables, machinery, materials and finished products.



Figure 7 (a) (b) and c): Three examples of industrial fans attached to walls or ceilings



Make local ventilation cost-effective

Local ventilation should only be considered as a means of reducing chemical hazards when other means have failed. There are cost-effective ways of improving ventilation.

Use proper fans

Apart from those used for ventilating workstations, fans may be utilized to remove dangerous substances from the workplace. Contaminated air can be pushed or blown outside by having more open windows. A few points should be considered:

- there should be no obstacles between the fan and opening. Anything in the way significantly reduces the desired effect
- the air speed should be low to reduce turbulence. In the garments industry, different fans are used; some use industrial fans or wall fans as shown in figure 7. There are advantages and disadvantages for these types of fans. Industrial fans are so powerful that workers near them may be affected. Ceiling fans of the rotary type may lift the cloth being sewn, hence speed should be controlled
- contaminated air should not be blown in the direction of other workers on the way to the opening
- care should be taken that air expelled from the workplace does not affect people outside the enterprise
- a fan may not be sufficient to remove vapours from hazardous fumes such as those sometimes used in silk-screen printing. Extractor systems to remove dust and hazardous chemicals should be installed. These systems may be quite expensive and it may be more economical to replace the hazardous chemicals.



Replace a dangerous substance with a safer one

Exposure to chemical substances used for cleaning and stain removal causes fatigue, headaches, dizziness and irritation of eyes and air passages as well as damage to the lungs. Many problems of chemical hazards can be solved at little or no cost.

Some garment enterprises use organic solvents for cleaning fabric and finished products. Organic solvents can be dangerous and expensive. It may be possible to replace organic solvents with safer substances. For example, stains of an oily origin or other can normally be removed with a soap-based cleaning solution. A 5-10 per cent solution of soap will normally be less expensive and less dangerous than an organic solvent.

If you use organic solvents, keep them properly stored and labelled. They should be very carefully handled and used sparingly (figures 8 and 9).

When using a cloth soaked with organic solvent, the worker should always wear protective gloves to avoid skin contact. Remember to discard damaged gloves; inappropriate or worn-out gloves which allow chemicals to penetrate can be more dangerous than wearing no gloves at all. All such operations should be done away from other personnel, in a well-ventilated area.

For removing bigger stains requiring the solvent to be sprayed, an appropriate respirator should be used. Do not use dust filters to protect against organic solvents as vapours from the spray will pass directly through these. Use a well-ventilated room with air blowing from the operator to the work and then directly outside.

If these cleaning operations are regularly done special attention should be given to the workplace. Cleaning operations should be organized in a well-conditioned and well-ventilated area. Respirators are compulsory and their maintenance is essential. Remember that wearing filter respirators is very strenuous due to the breathing effort required. The worker will tire more quickly and work performance will decrease. Therefore, filter respirators should not be worn for more than three hours a day.

Respirators using charcoal filters only have a limited lifetime, especially in a humid climate. In many cases, a filter will only last for one day and filters will lose their absorption capacity if they are not kept airtight. An air supplied respirator will in many cases be a better solution.

Alternatively, you may consider sending stained fabrics or garments to dry cleaners who have the proper facilities for this work.

Some workers may be allergic to cotton or other fabric fibres. Light cloth filters can be distributed to them (figure 10).



Figure 8: Containers with solvents should be clearly labelled. Workers should be informed when using dangerous solvents

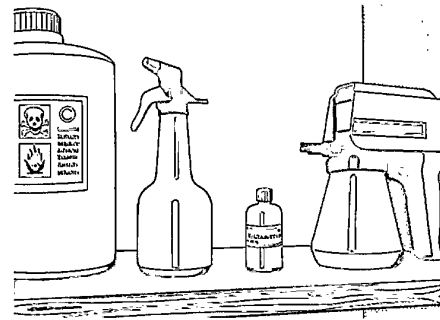

Figure 9: Provide proper storage for solvents, oils and other hazardous chemicals. Ensure all containers are closed properly after use



Figure 10: Light cloth masks help workers who are allergic to dust, cotton or other fabric fibres to breath unpolluted air

Summary

Rules for productive machine safety, maintenance and environmental control

1. Give your machines a productivity check.
2. Machine safety: eliminate, control or minimize the risk.
3. Purchase safe machines.
4. Maintain machines properly.
5. Teach workers to troubleshoot common machine problems.
6. Clean regularly and properly — do not spread dust.
7. Make local ventilation cost-effective.
8. Replace a dangerous substance with a safer one.

Good lighting for quality products

We receive 80 per cent of all information through our eyes. Although the human eye is very adaptable and can allow work with an absolute minimum of light, bad lighting leads to mistakes, poor quality and low productivity as well as eye strain, fatigue and headaches for the worker. Numerous studies confirm that better lighting pays off through higher efficiency. Improvements in lighting conditions in a number of industries have very often resulted in 10 per cent productivity growth and a reduction in errors by 30 per cent.

Better lighting does not mean more light bulbs and greater use of electricity. Natural lighting is often better than artificial lighting. The way artificial lighting is arranged and maintained is equally important. For example, a change in the visual background can enable a worker to perform a task efficiently, which otherwise would require tripling the lighting level.

You will learn from this chapter how to attain better lighting without increasing the electricity bill; you may even pay less and your business, as well as the workers, will definitely benefit from these improvements.

First of all, you must decide whether the existing lighting facilities need improvement. Lighting requirements are dependent on three main factors:

- the nature of the task
- the sharpness of the worker's eyesight
- the environment of the working area.

For example, a sewer needs concentrated light at needle point, so needle lights should always be fitted. A worker packing garments requires more overall lighting; in many cases packers work on special tiered work tops, where lights are built into the station. Age is also important: an older worker may need twice as much light as a younger one.

These factors make it difficult to calculate the required level of lighting using instruments and tables. However, you can learn much from going around the workplace, observing the workers and asking them about their visual problems. If you see workers adopting an awkward posture, with their eyes very close to their work, it is very

likely that there is a visual problem. It is important to identify the cause. For example, if there is a naked light in the worker's field of view, it definitely reduces his or her work efficiency. Dark ceilings, walls and floors reflect less light than paler ones.

Your programme of improvements may not have much impact if the workers' eyesight is insufficient. One study conducted in a factory discovered that 37 per cent of workers wearing glasses needed a new prescription and 69 per cent of those without glasses needed them. The same may be true for your enterprise. Therefore, an eyesight test for all workers should be carried out. Even if some workers do not follow advice about acquiring glasses, you will be aware of the problem and a possible reason for low efficiency.

With these ideas in mind, guidelines are provided below which will help you improve lighting in your factory.

Make full use of daylight

Natural light is the best and cheapest source of illumination, but very often small enterprises do not make full use of it. Measure the surface area of your shop-floor and of the windows and skylights. If you do not have at least one-third as much window surface as floor surface, your workers are probably not benefiting fully from natural light. Be careful, however: windows and skylights provide heat as well as light in hot weather (and cause heat loss in cold weather), and daylight varies depending on the season.

When thinking about fitting new windows and installing skylights, remember that the higher the window, the more light it gives. Skylights can give double the light of a low window, and low windows tend to get blocked by machines or storage containers. If your factory doesn't have skylights, consider replacing one or more opaque roof panels with translucent plastic (figure 1).

Well chosen paint colours and finishes on the ceiling, walls and equipment can help to cut lighting bills by one-quarter. At the same time, this helps to produce better visual conditions and a pleasant, cheerful working environment

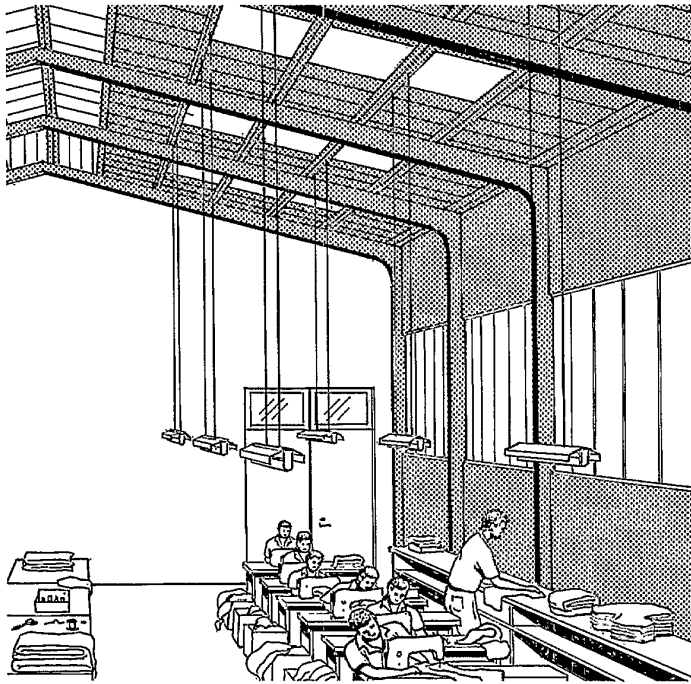

Figure 1: Clean skylights and high windows contribute to a good general natural lighting and provide good colour rendering

which encourages high standards of cleanliness and organization. Gains can be achieved from: lower losses of reflected light, better light diffusion and reduction of brightness contrast. In order to spread reflected light diffusely and evenly throughout the interior, ceilings should be as near white as possible. The matt finish of whitewash is very good. Many enterprises are adopting white tile ceilings.

To avoid harmful glare, don't use bright, shiny, gloss paint for walls. Pale colours are better than white. A slightly darker colour below eye level is helpful.

Lack of regular cleaning can result in the loss of at least 10 to 20 per cent of light. Special care should be taken to clean skylights, which are sometimes difficult to reach.

The colour of equipment such as sewing machines, workbenches and desk-tops should normally be matched with that of the walls. Nowadays normal machine colours are light beige, cream or light green and these assist in reflecting the light on dark colour fabrics, but not to the extent of reflecting light into the workers' eyes. These colours are much better than the black formerly used for the bodies or chrome finish for the tables, which reflect more glare.

An unequal distribution of natural light over the work area, particularly in sewing rooms, poses a problem. Take this into account and change the layout of benches and machines in order to minimize shadow zones. Workstations with high lighting requirements should be

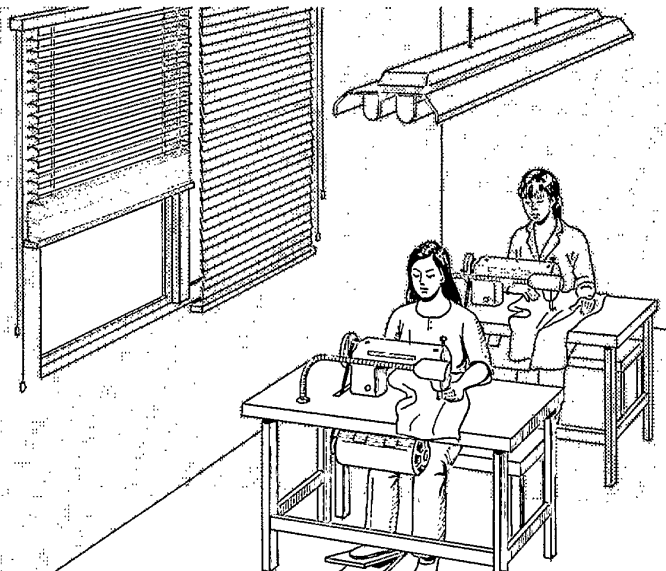

Figure 2: Tall windows allow natural lighting which can result in higher productivity. Blinds need to be provided to minimize direct sunlight and glare

moved closer to the windows and possibly be grouped together for the provision of additional lighting (figure 2). However, if the workstation layout responds well to your production needs, you may instead rearrange the distribution and height of the lamps or add needle lights.

Avoid glare

Glare means especially undesirable bright points or shining areas within the field of vision. Glare can contribute to errors, low quality and productivity. It causes a reduction in the workers' ability to see, discomfort, annoyance and eye fatigue. Visibility can be considerably improved without increasing light intensity by eliminating glare.

There are two types of glare: direct glare and reflected (indirect) glare.

Direct glare is caused by a light source (i.e. a naked bulb or direct sunlight) within the worker's field of vision (figures 3 and 4).

To reduce glare from windows:

- use blinds, curtains, louvres, shades, trees or vines (see Chapter 6 for more information)
- replace clear glass windows with translucent materials or glass blocks
- change the orientation of workstations.

Placing workers side-on to windows makes the best use of the light. Workers facing away from low windows are working in the shadow of their whole bodies.

To avoid glare from lamps:

- no naked light bulbs or tubes should be in the view of the worker when looking at the working area
- deep shades or shields could be employed
- shades should be mounted low enough to ensure that all bright surfaces are completely hidden, or high enough to ensure that they are well outside the normal field of view of the nearby workers.

Reflected (indirect) glare. Even if workers' eyes are protected from direct glare, they can still be bothered by reflected glare (figure 5). To reduce the distraction from light reflection on polished surfaces, such as shiny table tops or the sides of machines, you can:

- change the position of the light source
- lower the brightness of the source
- make the immediate background brighter by placing a light-coloured surface behind the work
- cover the table top with clean matt paper, white fabric or other appropriate non-glossy material
- change the orientation of the workstations.

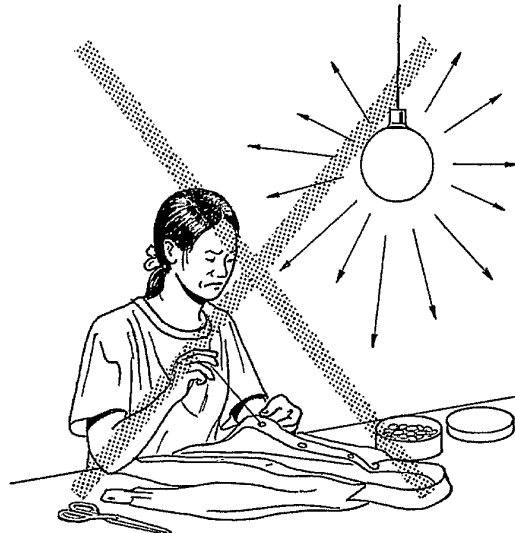

Figure 3: Avoid direct glare from a naked bulb



Figure 4: A shaded lamp should be placed at the appropriate height

Choose an appropriate visual work background

Visual work that demands close, continuous attention is performed with much less strain if the background is free from eye-catching distractions. Elimination or screening of potential distractions contributes to efficiency in all operations and improves quality control. This idea is particularly useful for quality control of transparent garments or other delicate items (figure 6).

For marking and inspection tasks on light coloured cloth the use of a dark background will also be helpful. Change the colour of the background to contrast with the colours of the cloth in use (figure 7).

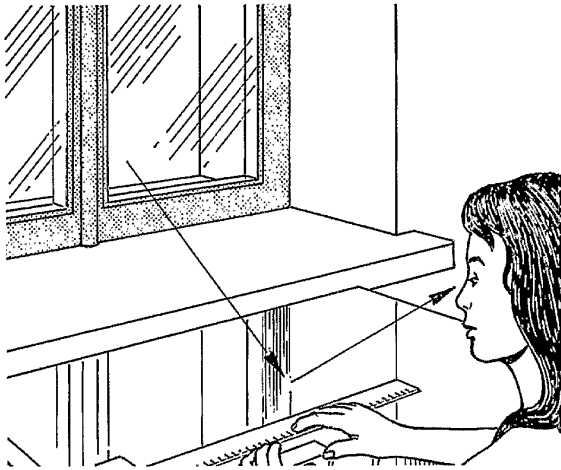

Figure 5 (a): Glare reflected from a polished surface reduces visibility. Reorientating the workstation by 90 degrees, or less, to the right or to the left will solve the problem

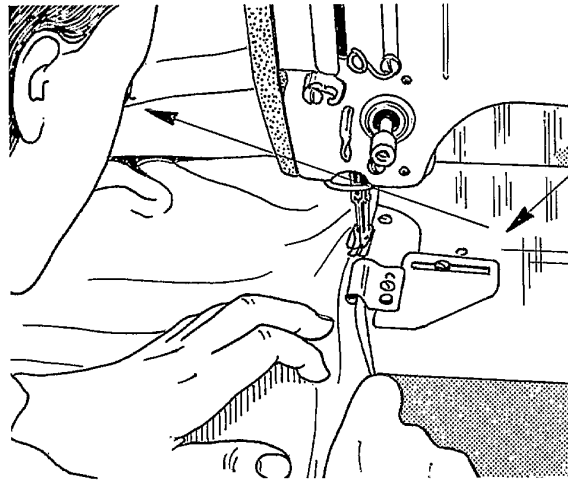

Figure 5 (b): In this sewing workstation, indirect glare can be avoided by changing the direction of the light source. Otherwise, a more opaque surface should be installed

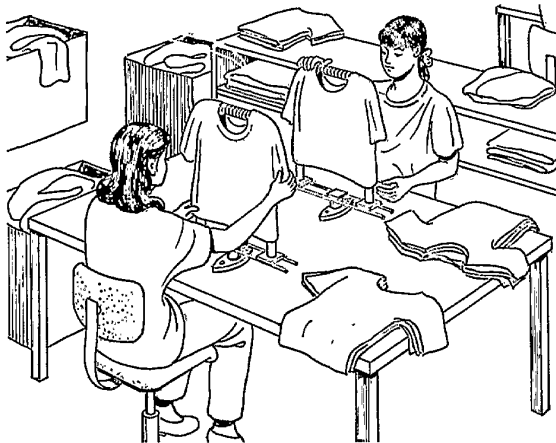

Figure 6 (a): Trimming or inspection tasks might be unnecessarily difficult

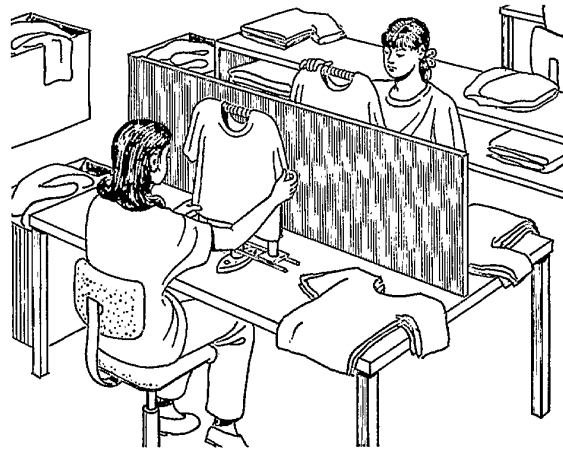

Figure 6 (b): A low detachable partition prevents visual distraction. This contributes much to operational efficiency in quality control tasks

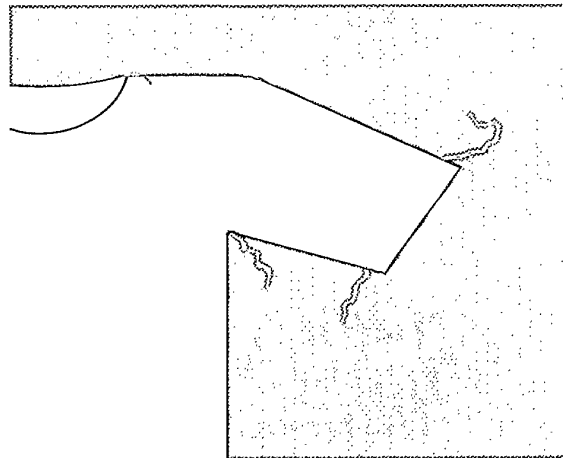

Figure 7: A good contrast between garment and background helps detect loose threads that need to be removed

Find the right place for light sources

Many garment enterprises have poor lighting arrangements, this is because little or no thought was given to the manufacturing layout. Light fittings should be located so that they reflect the most light. By changing the position of lamps and the direction of light falling on a work piece, it is possible at very low cost to improve visibility dramatically without increasing the total quantity of illumination.

To improve product quality and productivity, you have to determine the most appropriate light height and direction for the lights in order to :

- distinguish an object from its background
- reveal its surface texture
- enable any marking or defect to be easily seen.

Figure 8 shows the importance of finding the most appropriate light direction to distinguish any object from

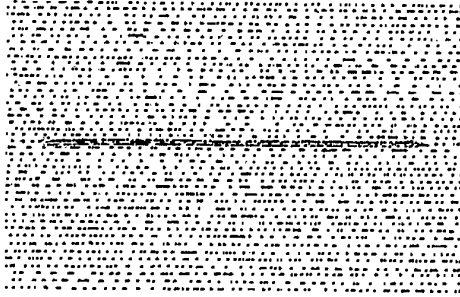

its background and reveal its shape. This is particularly useful in the garment industry in finishing tasks and quality control to detect faulty stitching or loose threads.

In most garment enterprises fluorescent light fittings are arranged either perpendicular or parallel to the sewing machines. Both may be acceptable. In general, a perpendicular distribution ensures more even light distribution than a parallel one. If perpendicular, the lights should be positioned along the machine heads, not above, to prevent shadows. The average ratio of light fittings to machines is 6:7, that is, almost one fitting per machine (figure 9).

The height of the lights from the work table is another important factor, not only for ensuring maximum illumination but for the visual comfort of workers. Lights positioned too low will generate heat and possibly glare, causing discomfort.

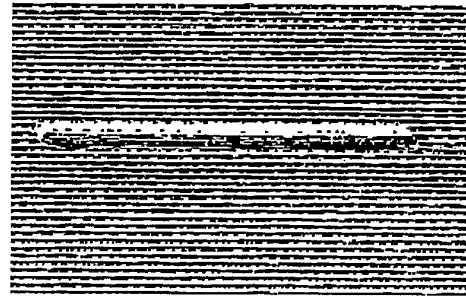

Figure 8: The position of the source of light is important for error detection (a) Lighting from above is less efficient than (b) surface illumination

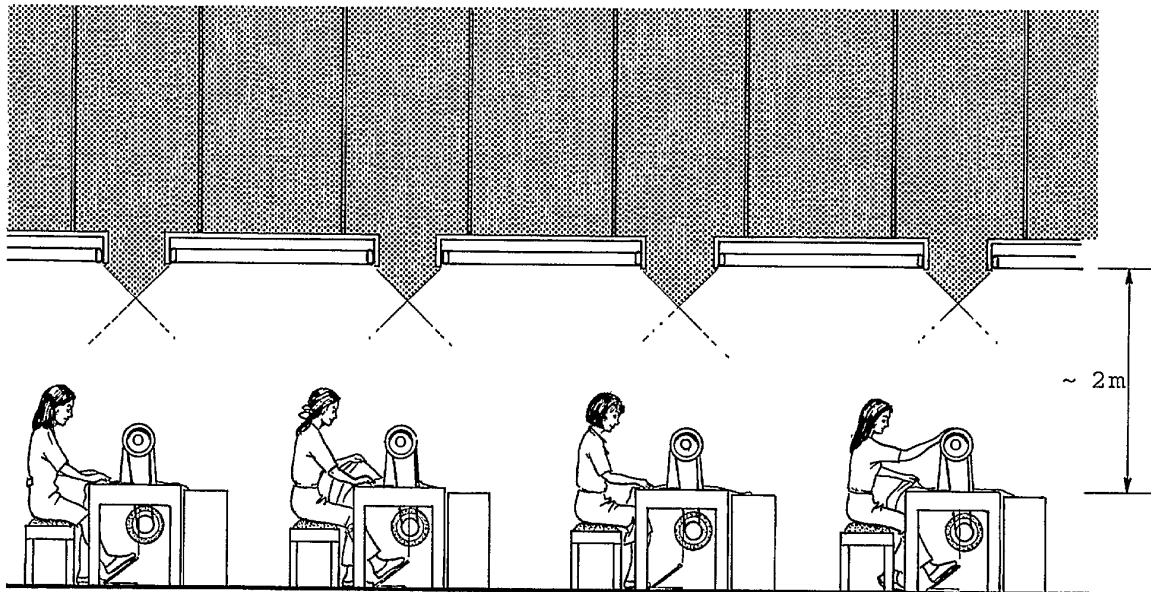

Figure 9: Correct positioning of lights in the sewing area when fluorescent tubes are perpendicular to the heads of machines. Note that tubes are drawn without shades for clarity but shades should not be removed

Use the right lighting device and fixture

Different lighting devices and fixtures are available in the market. Electricity consumption, level and quality of illumination, and cost are affected by the type of lighting used. Fluorescent lamps are recommended because they produce far more light per watt of electricity and have a longer life than incandescent bulbs. While the tube type of fluorescent lamp is commonly used at present, newer compact fluorescent lamps with low energy consumption are now available. These are relatively expensive and require a higher initial investment, but the savings on electricity consumption and maintenance will be substantial. Research shows the comparative data in Table 1.

The TLD type is a more advanced linear fluorescent lamp which has a better colour rendering quality. This helps in determining colour shades.

To save on electricity, install an individual switch for every light fitting as shown in figure 10. Train workers to switch off lights when they do not need them, particularly lights confined to individual workplaces.

Avoid shadows

Shadows make it difficult to work. It is hard to see into a shadow because the eyes will adjust to the surrounding brighter light. Sharp shadows on the work-surface are a source of poor work quality, low productivity, eyestrain, fatigue and sometimes accidents. See figure 11 for further information on different positions of light sources.

Many of the suggestions made so far will prevent shadows. If you have made improvements in any of the following areas, you have already reduced shadows:

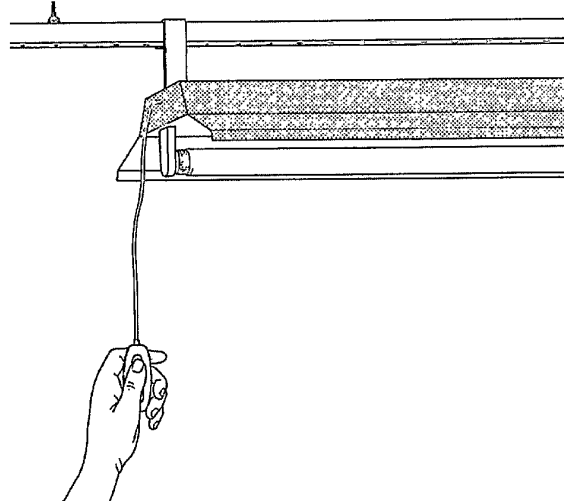

Figure 10: Individual switches for every single workstation could save electricity consumption

- more and clearer windows and skylights
- light-coloured, matt-surfaced ceilings and walls
- workstation layout and orientation which avoid shadow zones
- rows of lights for rows of machines
- better light direction
- needle and bench lights.

There is more you can do to control shadows. For example, you can improve the general luminosity considerably in the workshop by allowing from 10 to 40 per cent of light to escape upwards. In this case, light will be much better dispersed due to reflection from the ceiling. To profit from this improvement, the ceiling should be reasonably low, not obstructed and should be painted white. The openings in the top of industrial light

Table 1: Electricity consumption and effectiveness, comparative data

Type of lamp bulb and power (W)	Quantity of emitted light (lumens)	Luminous efficacy (lumens/w)	Average life (hours)	Relative cost of lamp bulb monetary unit (mu) ¹
Incandescent 25 watts	180-200	7.2-8	600	1 mu
Incandescent 50 watts	500-550	10-11	600	1 mu
Standard fluorescent tube 40 watts	800	20	5 000-7 500	3.5 mu
TLD fluorescent lamp 36 watts	800	22	8 000-10 000	4.0 mu
Compact fluorescent lamp 18 watts	800	24	8 000-10 000	15 mu

¹This and other comparative data cited below may vary according to local costs.

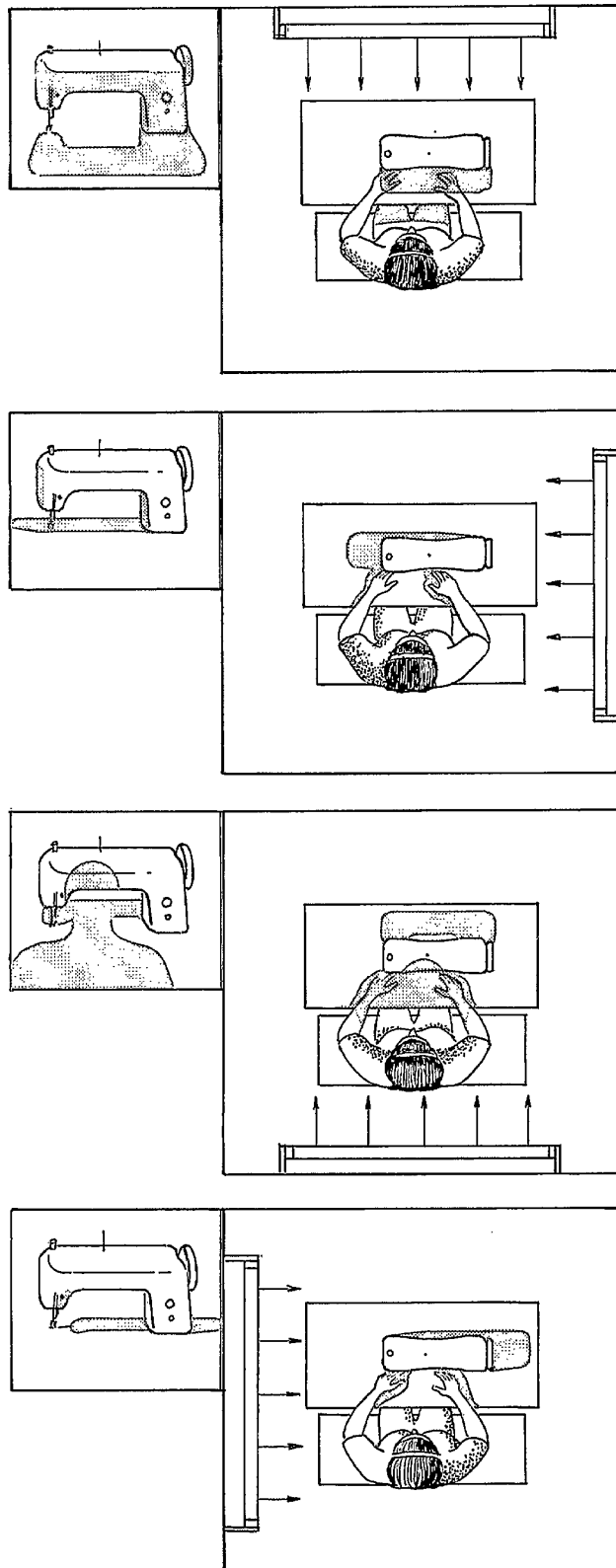

Figure 11: The risk of using a single light source on a sewing workstation. Problems vary according to its positioning: (a) light from the front and above – the working point is difficult to see and there is often glare; (b) light from the right side and above – this is better but much of the work item is still in shadow; (c) light from the back and above – the head and trunk of the worker create shadows over the working point; (d) light from the left side and above – this seems the best option.

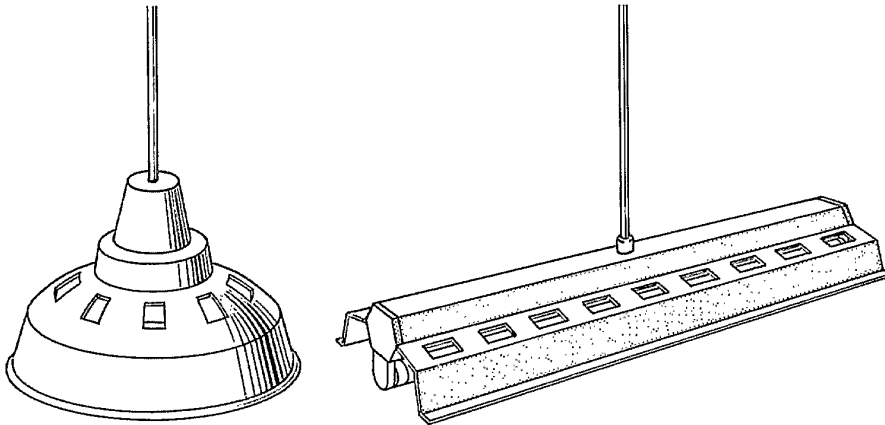

Figure 12: Lighting units with openings on top improve general illumination and provide for better lamp ventilation

fitting units allow ceiling illumination, better lamp ventilation and lower dirt accumulation than closed-top units (figure 12).

For work areas, where only artificial light is used, the spacing of the lighting units is very important. Figure 13 gives guidance on how to attain more even lighting conditions. Figure 14 illustrates a suggested distribution of light fittings in the case of a progressive line of production layout.

Local lighting

As mentioned at the beginning of this chapter, the specific lighting requirements at workplaces differ very much depending on the nature of the task as well as on the sharpness of the worker's eyesight. Precision tasks, like embroidering, fixing decorative details by hand or quality control tasks (i.e. detecting fabric defects and shortages), may require special lighting arrangements and additional local lights can be used. Properly arranged for such

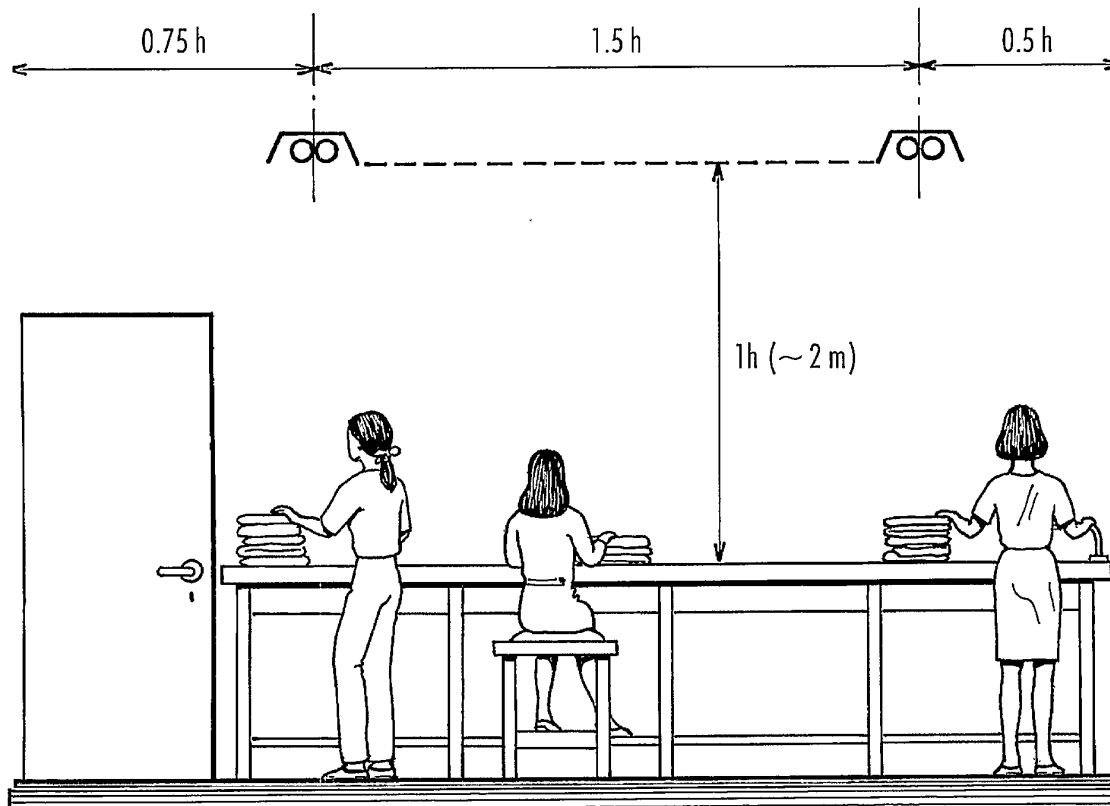

Figure 13: Recommended spacing for industrial-type lighting units. The distance from the work surface to the light fixture is h . Where there is a passageway near to the wall, the fixture should be at $0.75 h$ from the wall. When working close to walls, the fixture should also be closer ($0.5 h$) to it

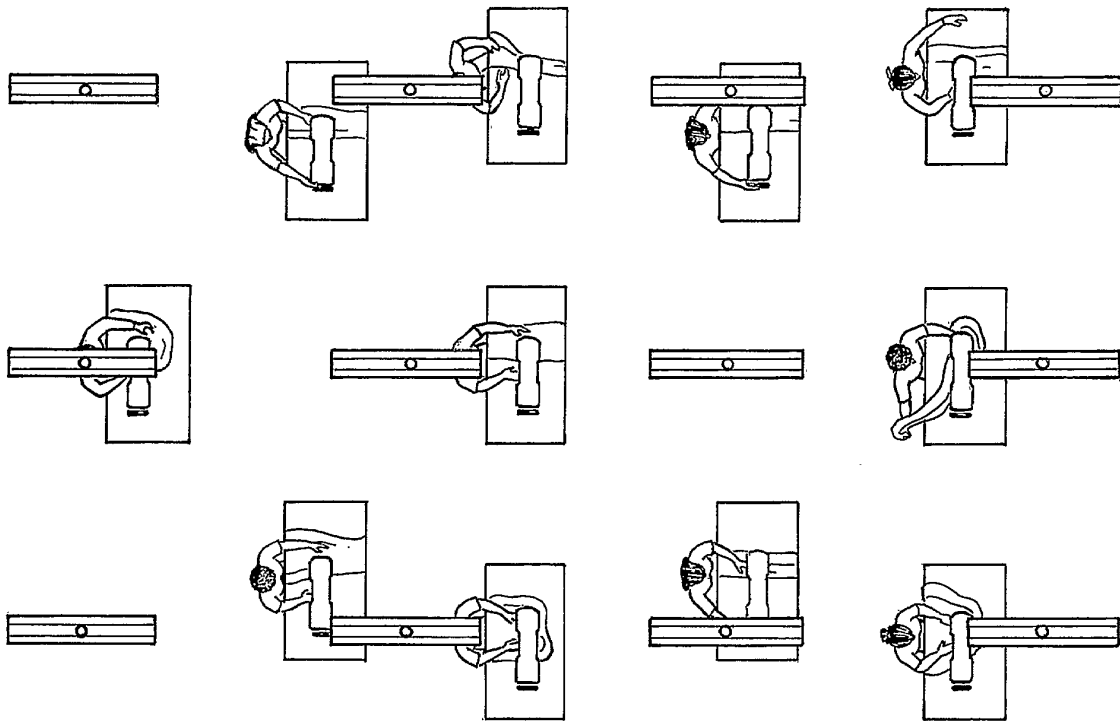

Figure 14: Suggested distribution of lighting points in the case of a progressive line production layout. Distances between sewing workstations may vary

meticulous tasks, local lighting will contribute to higher product quality and presentation, and increased productivity (figures 15 and 16).

Ensure regular maintenance

Even with the best new lighting installation, it is essential to establish a proper maintenance routine. Without maintenance, *the actual level of illumination could be half of the initial level in a few months' time.*

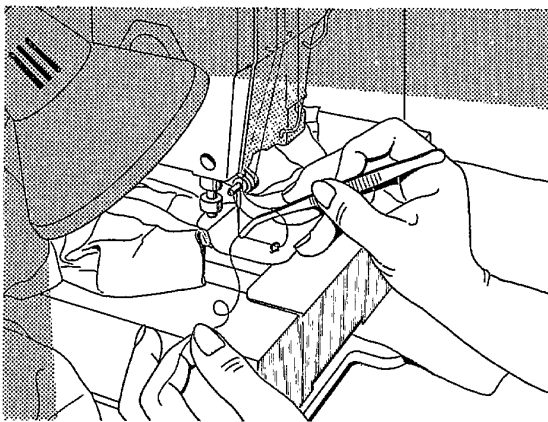

Figure 15: Precision tasks or older workers may need extra local lighting

There are a few main causes for loss of illumination:

- **Dust or other deposits on lamps.** The need for regular cleaning of lamps is often overlooked because dust collects relatively slowly and evenly. Dust which may be absorbing a large proportion of the emitted light is often difficult to detect. Table 2 shows that the type of fitting makes a big difference. If you decide to use a closed-top reflector or fitting (figure 17), clean it every month.

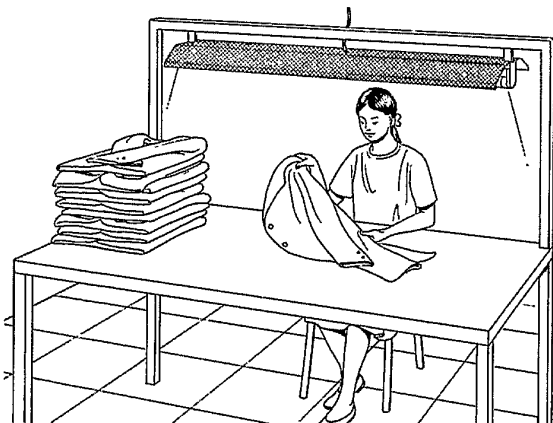

Figure 16: A bench light fitting for special workstations like quality control or packing tasks

Table 2: Percentage illumination loss over time

Type of fitting	3 months	6 months	9 months	12 months
Closed-top fitting	18%	25%	35%	40%
Open-top fitting	8%	12%	15%	18%

- **Loss in light output** from bulbs and fluorescent tubes throughout their life. For example, a fluorescent lamp can lose 25 to 30 per cent of its initial output before it burns out. That is why one should consider introducing a system of group lamp replacement at the same pre-determined time. Lamps which are removed need not be scrapped; they may be used in places such as corridors or little-used storing places. Some of them can be kept to replace lamps from the next batch which fail early.
- **Dirt on windows, skylights, ceilings and walls.** A 20 per cent increase in illumination or more can often be gained by regular cleaning of all windows and skylights inside and outside. It is also important to clean ceilings, walls and other interior surfaces, because of their contribution to light reflection.

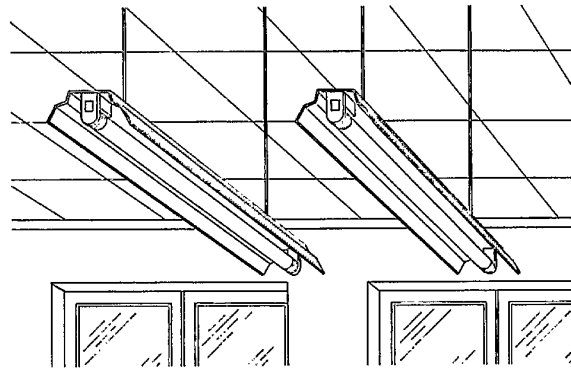

Figure 17: Fluorescent tubes with closed-top reflectors have to be cleaned every month

Summary

Rules for better lighting without increase in the electricity bill

1. Make full use of daylight.
2. Avoid glare.
3. Choose an appropriate visual task background.
4. Find the right place for light sources.
5. Use the right lighting device and fixture.
6. Avoid shadows.
7. Ensure regular maintenance.

Premises suited to production

Many small to medium enterprises are unable to design their own buildings or choose one which meets all their needs. In many small garment industries, the factory is a leased building, or even an extension of the owner's house. This is particularly true in some developing countries. Given this situation, very few companies have ideal workplaces.

Still there are many ways by which the working premises can be improved without heavy capital investment. This chapter discusses a series of simple and practical ways to improve the premises of your enterprise. Temperature control, better ventilation, properly designed floors and layout, and attention to fire and electrical safety can increase the workers' efficiency and avoid large losses. The following rules can also make your factory more attractive to customers and improve your image as an entrepreneur.

Protect your premises from outside heat and cold

One of the most important conditions for productive work is the correct temperature inside the work premises. The optimum will vary according to the local climatic conditions, the season, and the type and intensity of work. A comfortable temperature range will be from 20 to 25°C. Deviations from this temperature range inside the work premises can be very costly and result in lower productivity. Proper measures are needed to reduce the penetration of heat or cold from outside.

There are two basic ways heat or cold gets inside the factory: direct (through openings such as windows, doors, gaps or skylights) and indirect by conduction through the

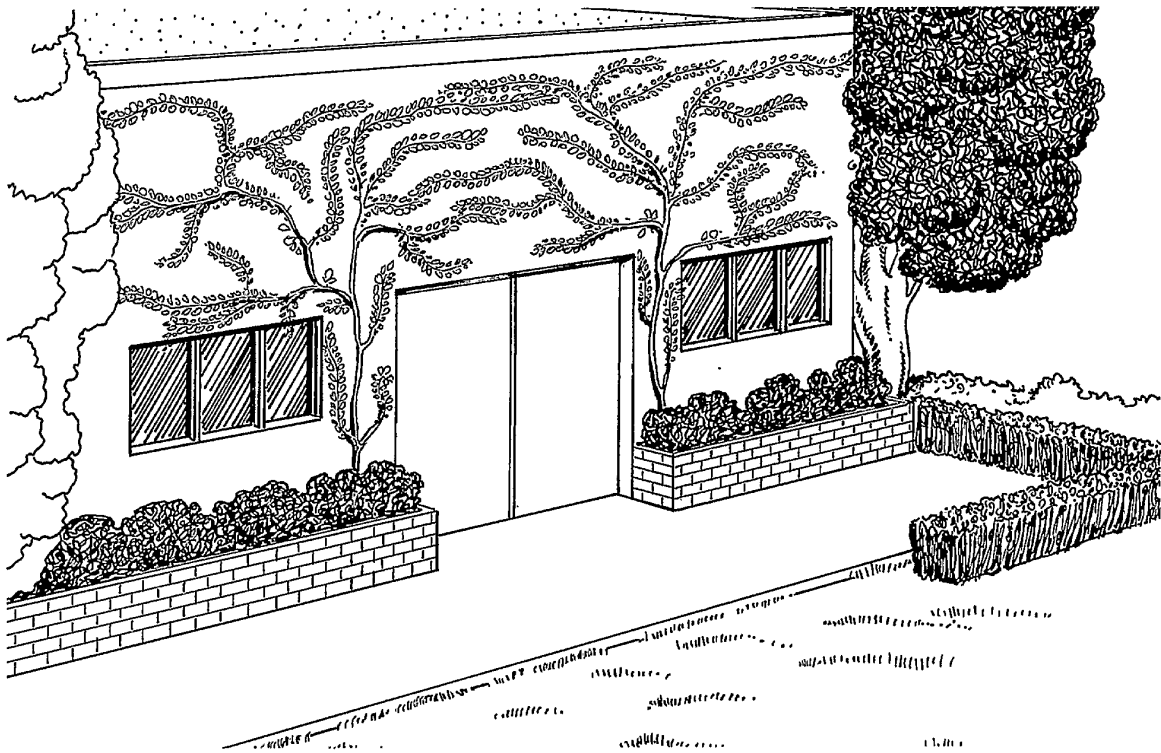

Figure 1: Trees, bushes and climbing plants are good natural protection for preventing heat absorption by walls

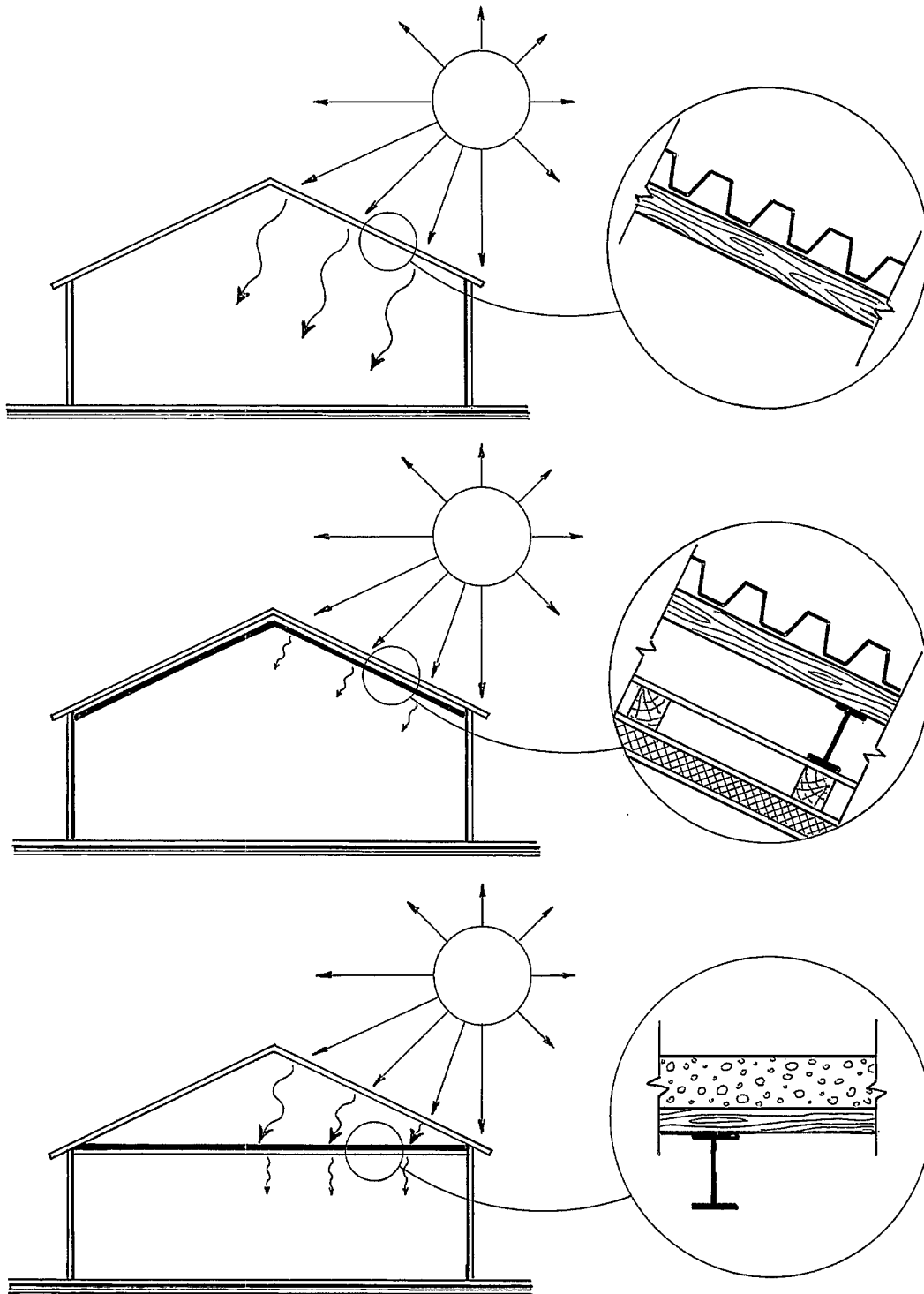

Figure 2: (a) A factory roof and walls made of single metal sheets gives a very low level of thermal insulation; (b) an appropriate ceiling and double layered walls can considerably reduce heat and cold penetration; (c) construction of a flat ceiling is another effective way of reducing penetration of radiant heat. Adopting this solution depends on the height at which the ceiling can be placed

fabric of the roof, walls and floor. In addition, sunlight coming through windows and skylights falls on objects inside the factory and heats them up.

If your enterprise is located in a subtropical country with cold winters you will also need to protect workers from cold. Ensure that entrance and external doors are designed with double contact surfaces. Windows and skylights should also be surfaced and sealed to prevent warm air escaping.

Let nature help you

Keep the enterprise premises green by planting trees and flowers (figure 1). Trees, bushes, grass and flowers help to reduce the harmful effects of the sun's radiation and hot winds. They also form a natural "filter" preventing dust from penetrating inside the factory. If there are trees surrounding the factory building have their side branches trimmed off up to at least three metres from the ground to allow a fresh breeze to get into the factory. Install some benches under the trees for workers to rest during their break times. Fresh air will invigorate them. Keep bushes below 1.5 metres to allow currents of air to reach the building.

Improve the heat reflection of the walls and roof

The texture and colour of the outside walls and roof are mainly responsible for the reflection or absorption of heat. Untreated concrete or brick walls transmit a lot of heat into the interior. To reduce this effect, the external side of walls and the roof should be smooth in texture and light in colour, preferably white.

Improve heat insulation

A thin metal wall or roof does not protect against penetration of heat or cold (figure 2a). Use double layer walls to prevent heat from entering and leaving through the walls. The layer of air between two walls is a good insulator.

Whatever the material used (concrete, tiles, metal sheets) and the shape (flat, inclined, gable, parabolic) of the roof, it is often worth investing in the construction of a ceiling. This will improve the thermal conditions in the workshop. Do not forget to insulate the ceiling with a layer of any heat-insulating material you may find locally (plywood, polystyrene, glass fibre, etc.). Even earth will do. **Warning: Do not use asbestos as insulating material** (figures 2b and 2c).

Use shades to protect against heat from the sun

Shades can do a lot to keep the temperature down in your factory. Properly designed shades work in two ways: they protect the walls from solar radiation and also absorb outside heat without transmitting it to the interior. Moreover, they help to improve lighting conditions by reducing glare and dispersing the light more evenly.

Good evergreen trees planted on the sides of the building are a natural and efficient means of providing shade.

Another practical and low-cost solution is to attach light-coloured vertical screens to the outside of the windows (figure 3). They can be permanently fixed (a) or adjustable (b).

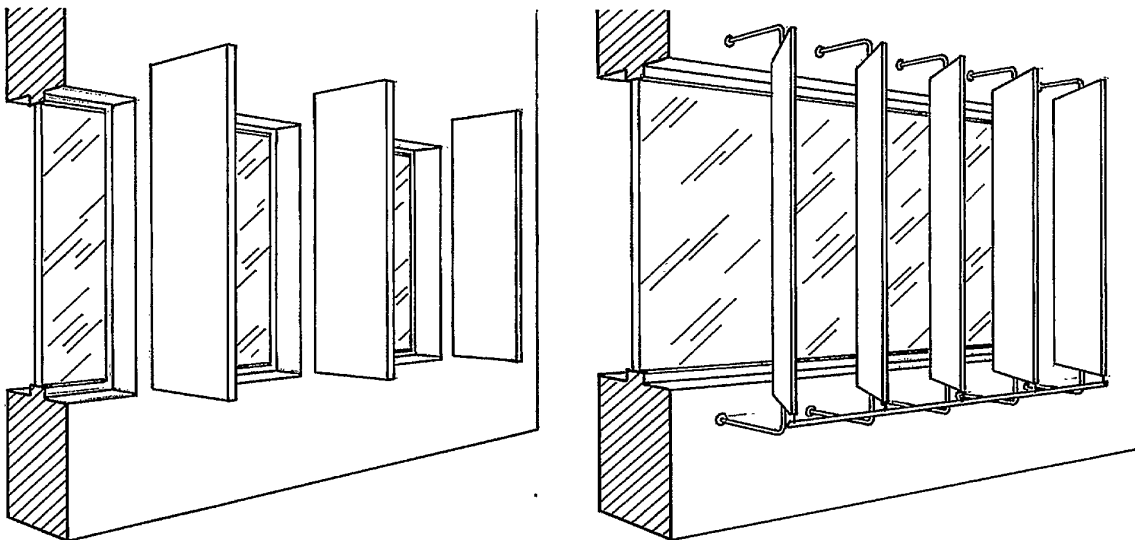

Figure 3: External vertical screens against solar radiation (a) permanently fixed; (b) adjustable

In tropical countries, vertical screens can be used effectively in combination with horizontal shades. The horizontal shades block out the sunlight when the sun is high in the sky (figures 4 and 5). Another possible design is permanent comb-type shades (figure 6).

All these shades can be home-made and fixed on the outside walls to protect windows which are most exposed to the sun. Remember that their effectiveness depends on the orientation of the windows regarding the rise and fall of the sun. You should select the most convenient according to your needs.

To improve further the protection of the building against solar heat, you can consider the use of sun-reflecting films or even coloured glass. The simplest solution is to paint the upper part of the window glass with a water solution of blue dye or laundry-bluing. Try it – it works.

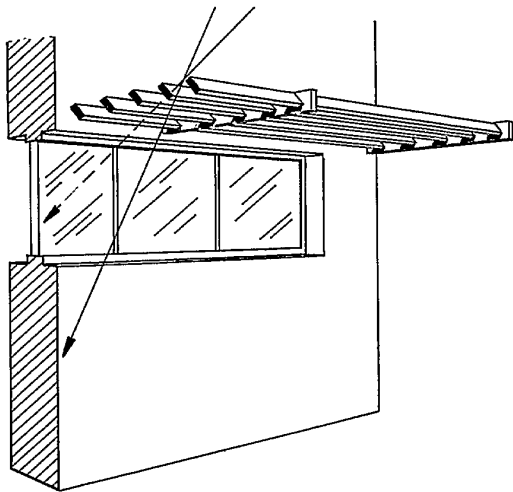

Figure 4: A canopy made of a row of planks. This provides good protection against heat penetration, and better lighting conditions than a solid canopy

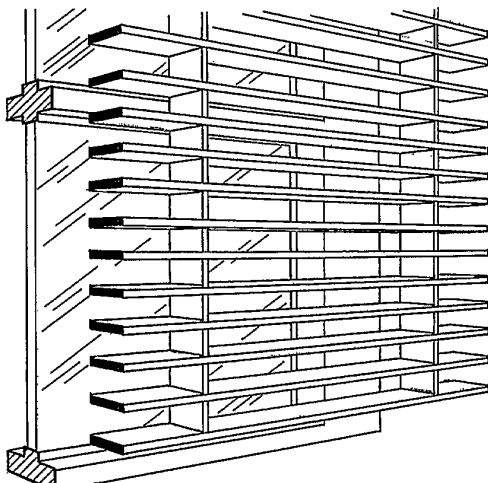

Figure 5: External louvres made of wood planks give all-day protection against solar radiation

Let natural air-flow improve ventilation

If there is not sufficient ventilation, the air in the production area quickly becomes contaminated by dust, vapours from ironing and gases. In the average workshop, the air needs to be changed between eight and 12 times per hour. There should be at least 10 cubic metres of air per worker. The smaller the room, the higher the air-flow should be. All working premises have some natural ventilation, but this fresh air supply is seldom sufficient especially in hot countries.

Ventilation should not be confused with air circulation inside the factory: the first replaces contaminated air with fresh air, whereas the second is intended only to improve thermal comfort by moving the air without renewing it. Figure 7 and others give some ideas for improving ventilation in production shops. However, the specific design of your working premises and the characteristics of local climate conditions may require other adaptations. Use this idea as a general guide and, if possible, consult a local architect or specialist in ventilation.

Make better use of horizontal air-flow

Horizontal air-flow helps to improve thermal comfort and remove pollution. Open windows are a popular and simple way of providing cross ventilation – wire-mesh screens assist in reducing airborne particles, insects or small birds. Multi-section windows help to regulate airflow according to wind conditions (figure 8). Workstations generating vapours or dust should have a good horizontal air flow to improve ventilation.

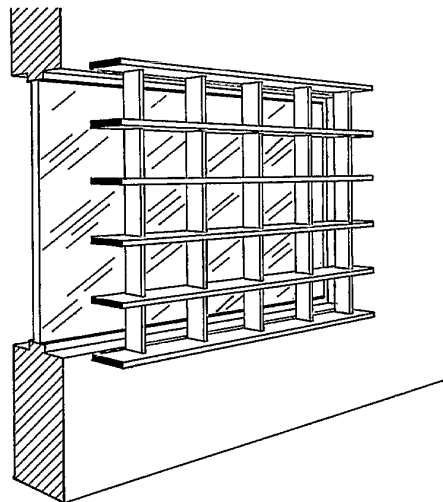

Figure 6: External comb-type shades

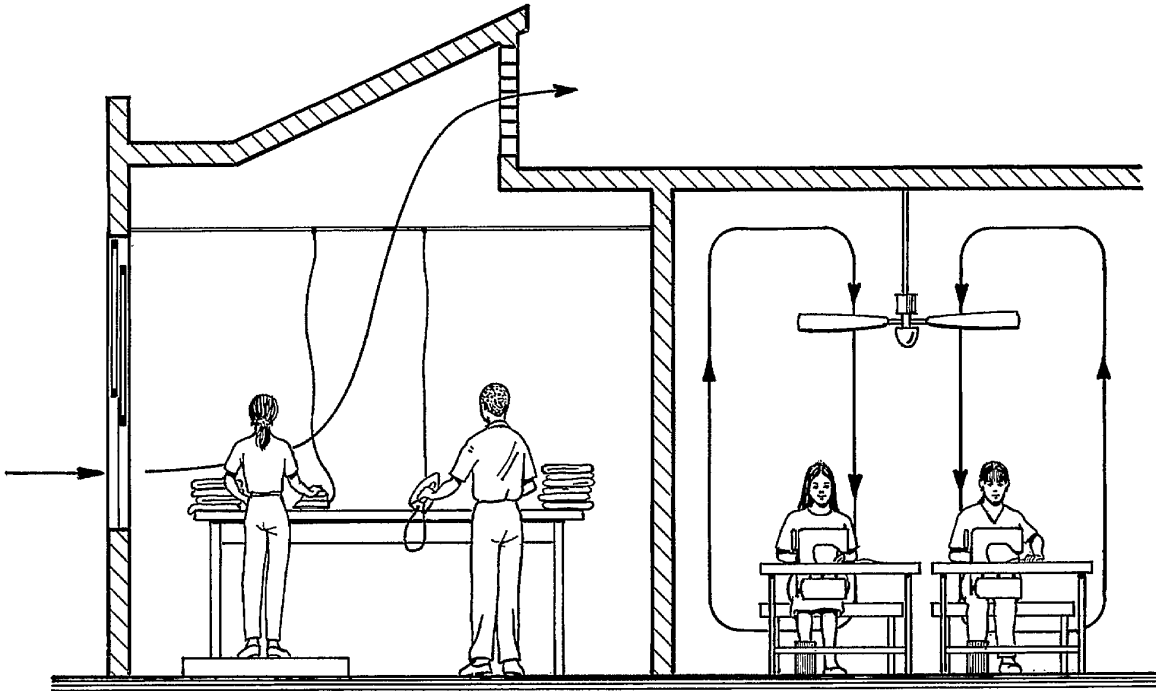

Figure 7: (a) Ventilation means renewal of air; (b) air circulation means moving internal air. Both principles contribute to better worker comfort

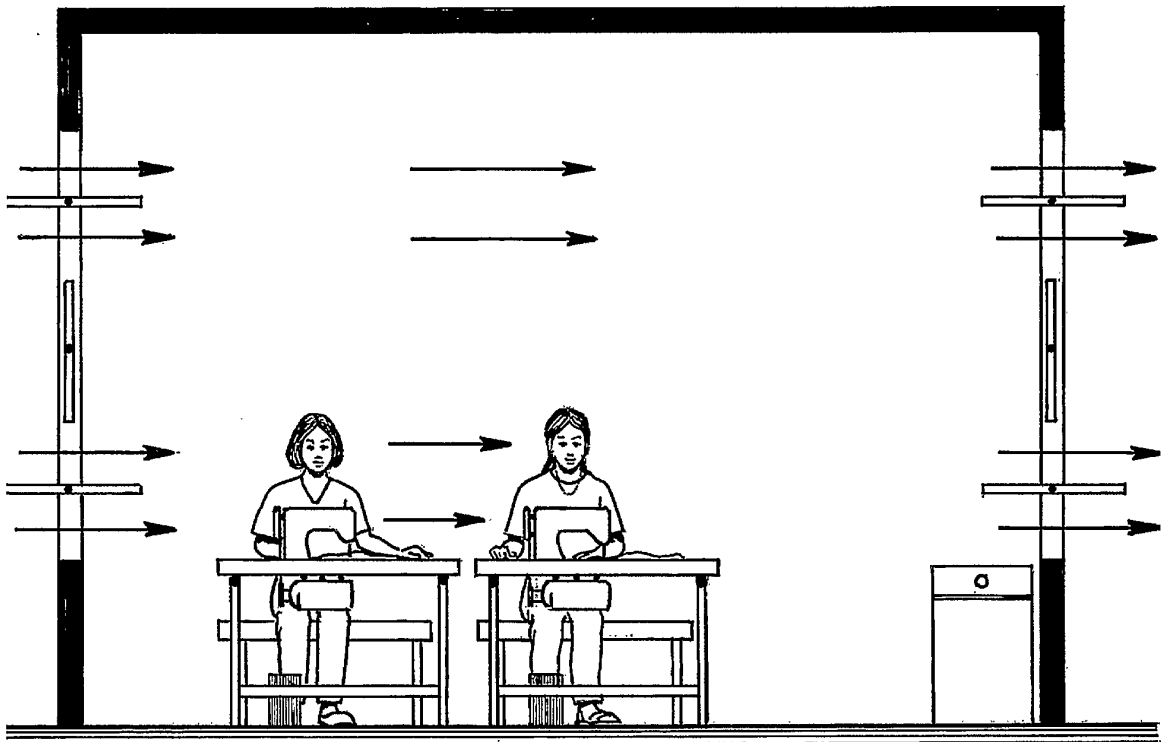

Figure 8: Natural cross ventilation from adjustable openings on opposite sides of a sewing room is a good solution for air renewal

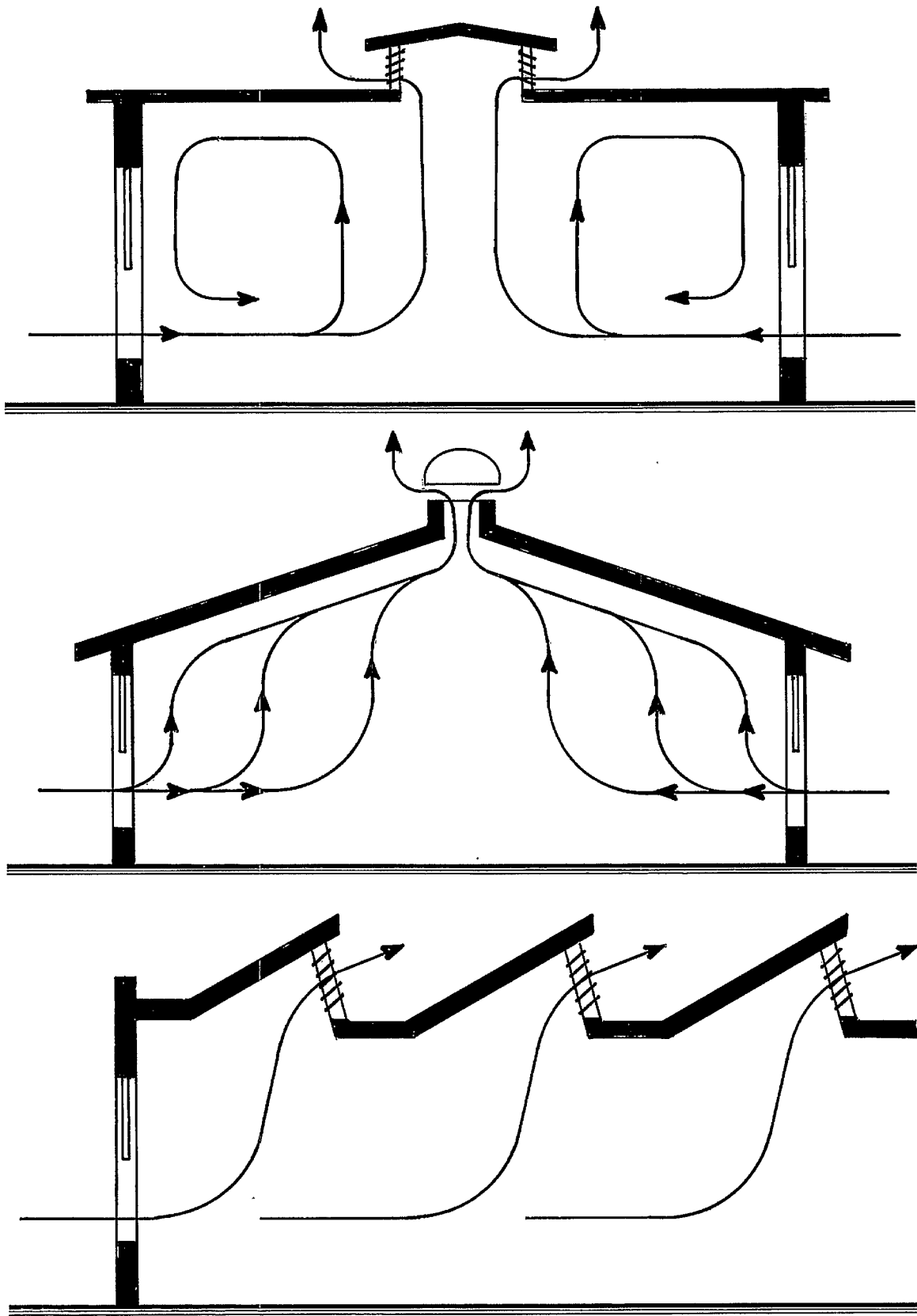

Figure 9: Natural air-flow routes on buildings with different roof designs

Utilize the tendency of hot air to rise

Usually it is not possible to provide sufficient ventilation in a large production area by opening windows or using wall fans. Inevitably, in the middle of the workshop there will be an area with no air movement at all. This problem can be resolved by using the natural upward flow of heated air, the "chimney" effect. This can be done by providing sufficient openings in the roof, i.e. adjustable louvres or exhaust deflectors. The shape of the roof very much influences the effectiveness of natural ventilation. Inclination of the ceiling towards the roof helps to avoid pockets of hot air (figure 9).

In tropical countries, walls built with hollow bricks and special pre-cast concrete panels with fixed louvres facilitate the entry of fresh air (figure 10). In the upper part of the walls, where the roof leans against them, horizontal slots can be left allowing fresh air to cool the inner side of the roof (figure 11).

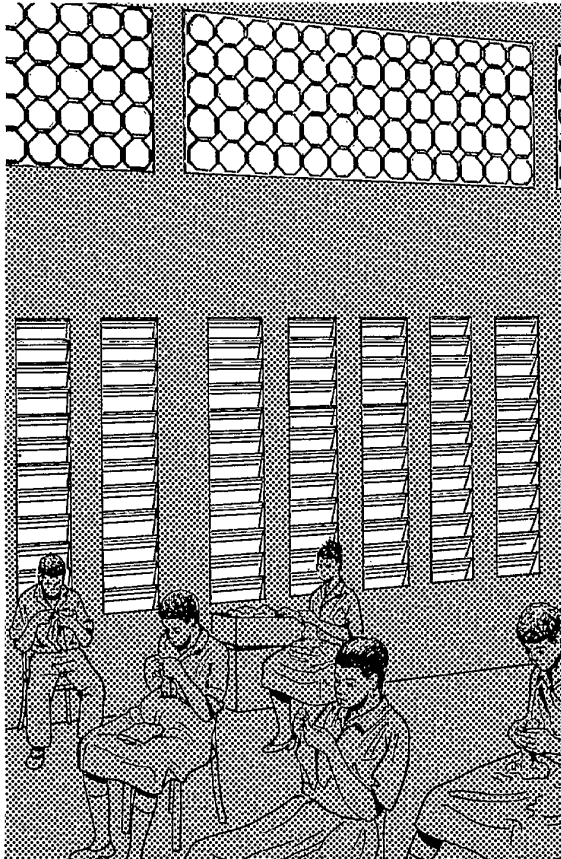

Figure 10: In hot tropical countries walls provided with special bricks and pre-cast concrete panels with fixed louvres improve the intake of fresh air

Improve your floor surface

We are inclined to underestimate the importance of the floor for productive, smooth and safe work. Inappropriate floor surfaces, or poorly maintained floors, can be a major source of accidents, work interruptions and product damage.

For garment producers, the floors should be flat to ensure stability of machines, efficient and safe movement of workers and to ease the displacement of movable material-handling equipment. The main floor technical properties are:

- good compression resistance, to facilitate the movement of wheeled containers and mobile racks
- good resistance to wear and abrasion, to avoid dust formation and to have sufficient resistance to withstand normal use over many years
- very good ease of cleaning and washing



Figure 11: Horizontal slots in the upper part of walls help to cool the roof allowing the intake of cooler air

- fairly good resistance to chemicals, particularly good oil resistance to avoid floor deterioration below sewing and other lubricated machines. Resistance to synthetic acid and disperse-dye solutions and pigments is also important.

The most convenient optional floor coverings are concrete, plastic and ceramic tiles. Floors which are frequently washed down with water should have an even gradient of 1–2 per cent towards a drain to ensure that the water flows away from the traffic area.

Carrying bulky bundles on an uneven or slippery floor is a common cause of accidents. Transport surfaces can be covered or painted with high-friction coatings which reduce the risk of slipping but do not influence rolling resistance of carts and movable racks.

Sudden height differences in passageways impede easy transport of containers and carts, and can cause accidents. Remove height differences and fill or bridge such places. If these obstacles are structural, provide gradually inclined covers so as to avoid stumbling or wheel barriers (see figures 12, 13, 14 and 15).

Provide ramps to eliminate the need for steps or stairs (figure 16). Ramps with a small slope between 5–8 per cent (5–8 cm of height for every 100 cm horizontally) greatly facilitate the transport of work items on carts. Make sure that the surface of the ramps is always dry, smooth and non-slippery. Non-slip pads and stripes should be used on stairs.

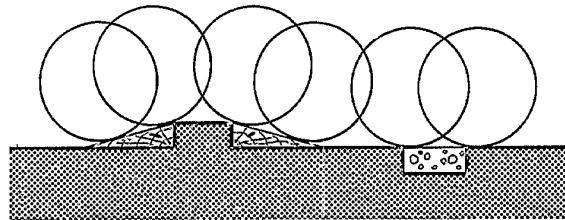
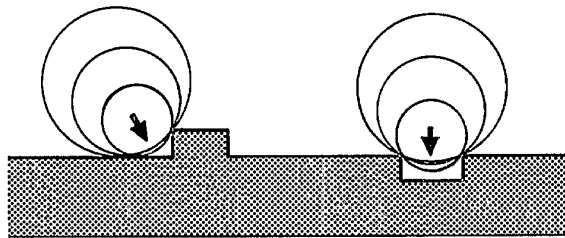

Figure 12: (a) Remove sudden height differences wherever possible. Larger wheels are generally better than smaller ones as they can more easily overcome obstacles or hollows. (b) Fill in or bridge sunken places. If height differences remain, provide gradually inclined covers so as to avoid stumbling or wheel obstacles

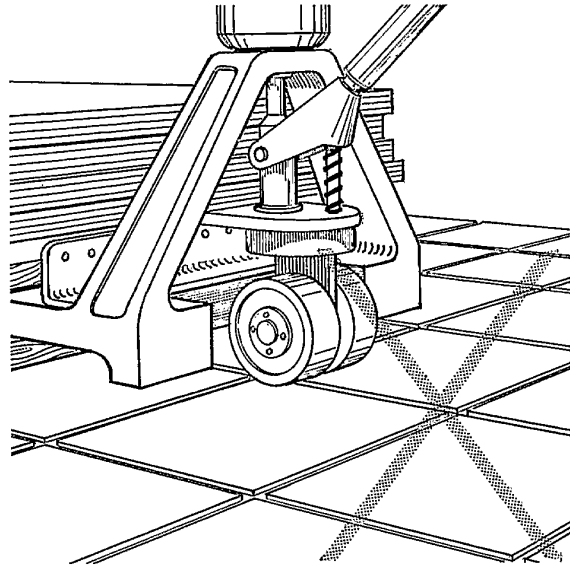

Figure 13: Flooring should be as complete as possible. Tile joints should be filled up to ensure smooth and silent transportation

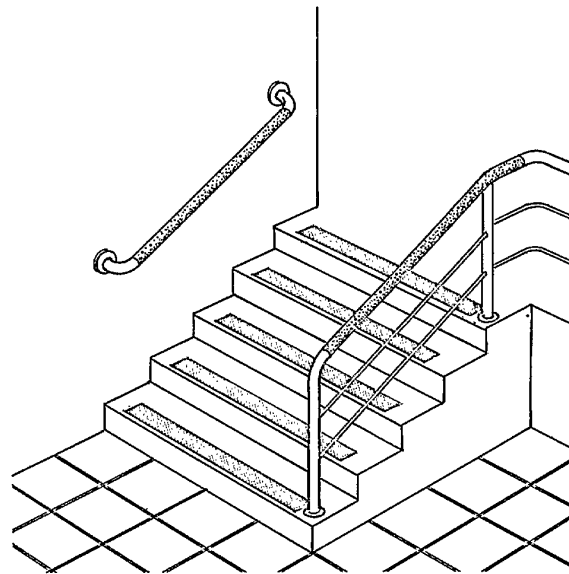

Figure 14: Install non-slip pads or strip bands to prevent slipping on stairs or ramps

Build flexibility and adaptability into your plant layout

When you are setting up or modernizing your production facilities, it is the right time to improve space allocation, transport arrangements, production routes and the infrastructure of the building. Following a few rules will help to adapt the layout of workstations and storage areas to quickly organize production according to changing needs. It will also help to complete orders on time.

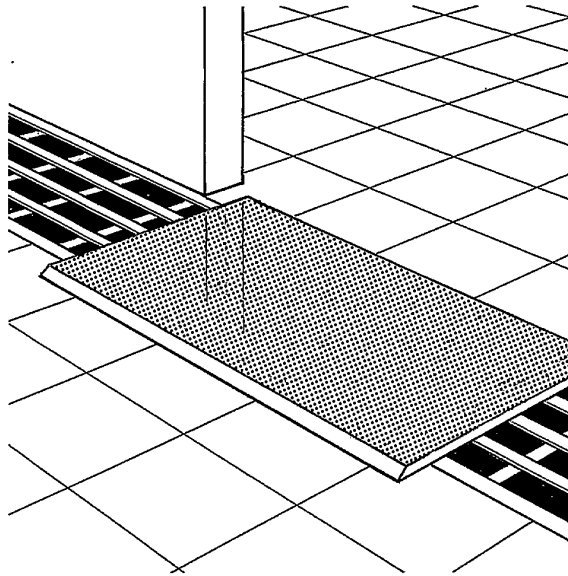

Figure 15: Where bridging is needed, make sure that the surface is even, not slippery and allows the passage of wheels

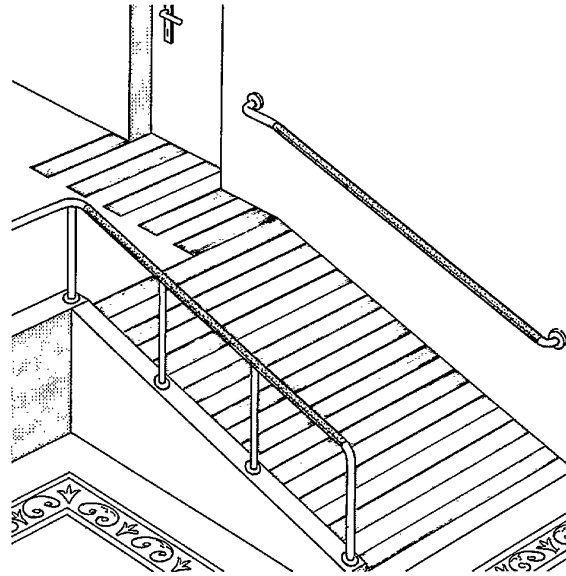

Figure 16: Provide ramps instead of stairways. Keep the angle of inclination of ramps below 15 degrees

Reserve free space in the work area – otherwise you will find it quickly becomes overcrowded, with no space for extra tasks or increased production. This will help to avoid blockages of passageways. Provide space for additional machines in case of expansion or transfer of special machines for a particular process.

Allocate sufficient passageways and make sure that they are kept clear. Often in small garment enterprises, little care is taken to provide adequate passageways for efficient and

safe movement of materials. In addition, passageways tend to become filled with bolts, bundles and containers. You should define passageways clearly; these can be marked, as well as work and storage areas, by drawing easily visible border lines of different colours (for example green – work area; brown – passageways; grey – storage area; yellow – line marking boundaries). You can paint them or use special marking tapes. Make sure that everyone knows that the zones are to be respected. Never allow anyone to put anything down except where it belongs (figure 17).

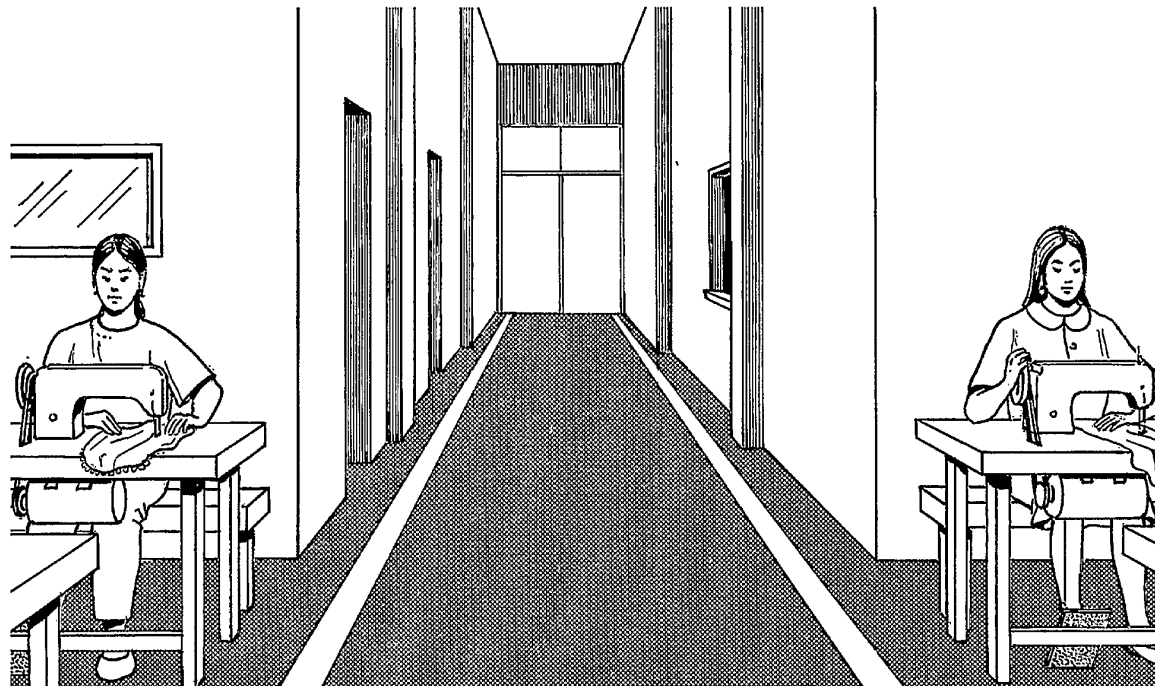

Figure 17: Define passageways by painting colour and lines on the floor

Use production equipment and storage facilities which are easy to assemble and to dismantle. Always give preference to equipment and storage units supplied in "modular kits". These enable you to set up, move or replace a workstation in a very short time and with a minimum of disturbance to production.

Provide evenly distributed general lighting and supply circuits throughout the production area, instead of installing them according to the power or a particular production layout. Since positioning of lighting is critical to the position of machines, both should be thought out thoroughly and simultaneously (see Chapter 5).

When planning the layout of your workshop you should consider the floor area required by work/activity sectors, circulation zones and storage areas. The required floor area of the most common workplaces like sewing, cutting, ironing and packing workstations, including chairs and storage containers, should be known and available when planning your layout. The floor area needed and the quantity of racks, carts, pallets, containers, cabinets and buffers also need to be considered.

Prevent fires and electrical accidents

Fire

Fire in your work area can ruin your whole business and cause serious injuries or even deaths. Fire protection should always be a priority. Following these simple rules can help prevent fires or reduce fire damage if one occurs.

Prevention

Prevent fires by making sure that rubbish and other inflammable scrap materials are cleaned up, placed in metal containers and stored outside the workshop. In addition, follow the rules below concerning common sources of fire:

- **electricity:** ensure that electrical circuits are enclosed, insulated, earthed and properly fused; check that electrical circuits are not overloaded (see next section, on electrical hazards)
- **friction:** properly lubricate moving parts of machines; make sure that moving belts or drives do not rub against housings
- **hot irons:** make sure irons do not overheat and have appropriate clear controls. ensure that they are placed only on stable, insulated surfaces when not in use (figure 18)
- **combustible and flammable material:** keep it away from irons and flat-bed transfer machines using heat fusion processes.

Escape routes from the work area

Firstly, make sure that every floor or large room has at least two ways out and that these exits are kept unobstructed and unlocked. Clearly mark escape routes and exits and provide sufficient lighting and directional signs so that there is no confusion in reaching exits. Secondly, make sure everyone knows what should be done in case of fire. Thirdly, make a plan for emergency escape,

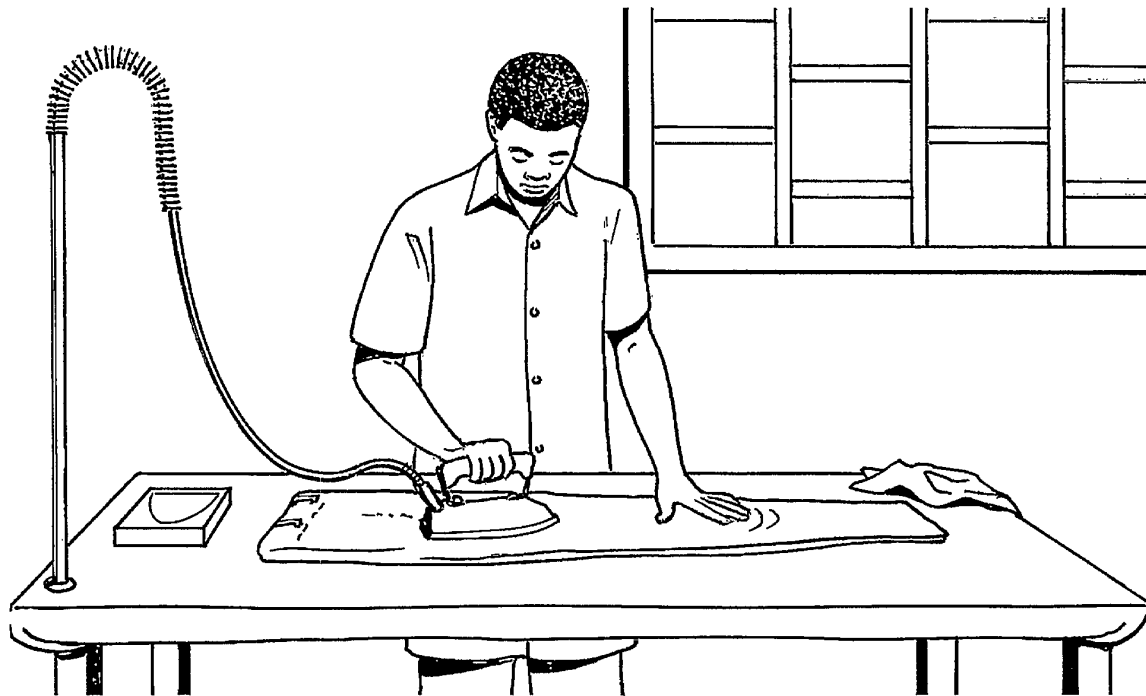

Figure 18: A manual ironing workstation

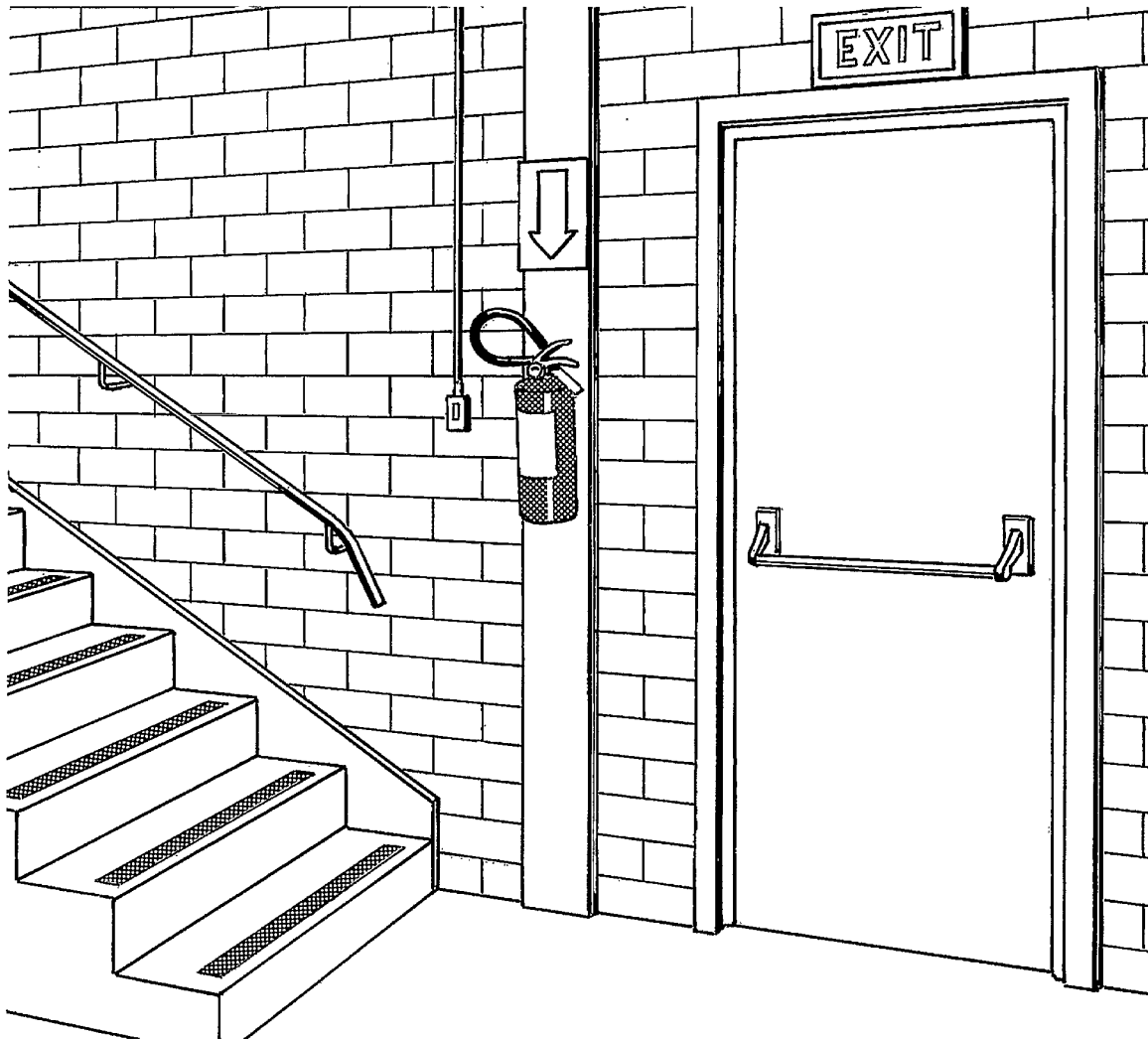

Figure 19: Fire extinguishers should be placed near the sources of potential fires. Be sure that extinguishers are within easy reach, are properly maintained and can be operated by workers

including a place to gather outside the factory where you can account for everyone and be sure no one is still inside.

Fire fighting

Provide appropriate fire extinguishers and fire fighting equipment near the sources of potential fire. Check the equipment regularly. Assign responsibilities for fire-fighting and train workers appropriately – the supplier of your equipment can help you with this (figures 19 and 20).

Electrical hazards

People tend to ignore electrical hazards. The abuse of safety rules whilst working with electricity is a prime reason for fatal accidents and fire. The following rules can help you to reduce electrical hazards.

Prevention

Establish a firm rule that any repair or maintenance work on sewing or other powered machines should only be done when the power is turned off and the switch is locked in the “off” position. The key to the lock of the power switch box should be in the pocket of the person doing the work.

In addition to this basic rule:

- circuits should never be overloaded
- avoid multiple adaptors and loose extension leads
- be sure that all electrical wiring is identified and protected; there should not be any exposed wiring. Run wiring across the ceiling and down to machines, not across the floor
- all circuits should be protected with circuit breakers or fuses; this protects the machines against damage and the workshop against fire

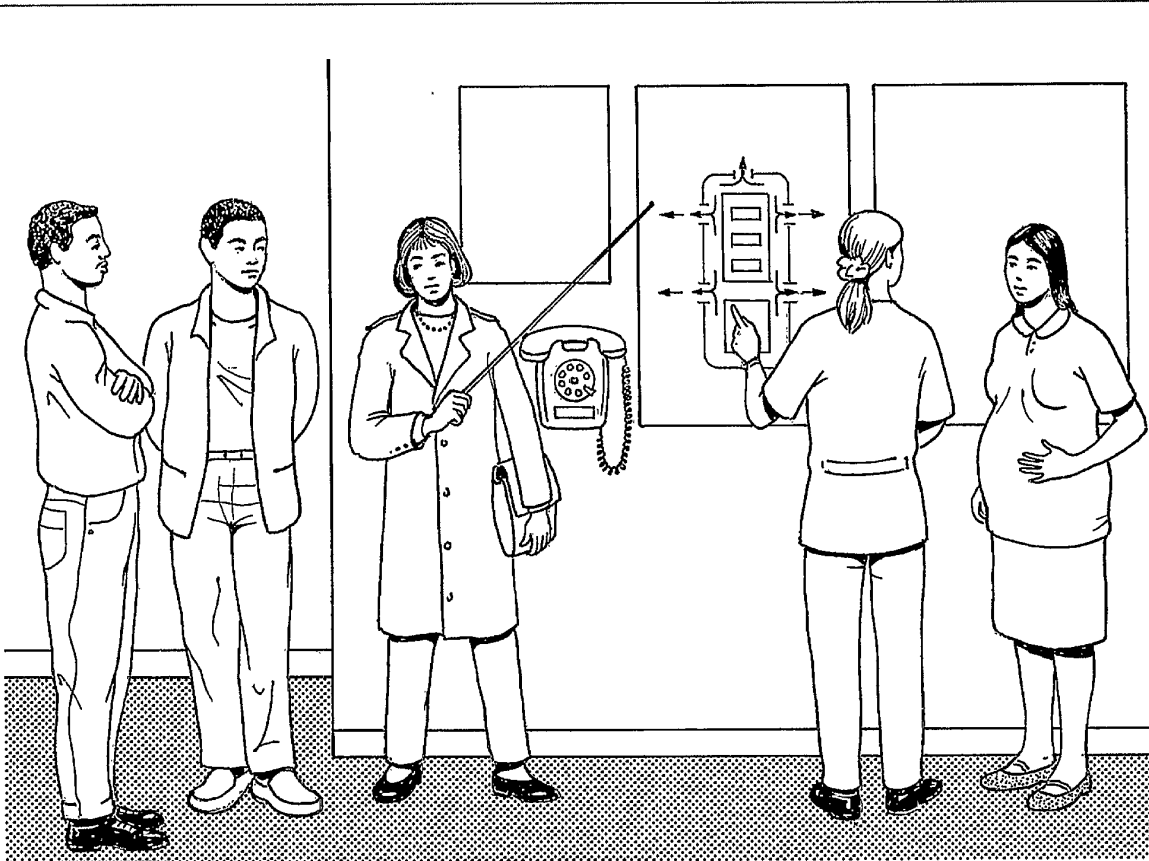

Figure 20: Design emergency action plans with the participation of workers

- all equipment should be earthed and separate earthing wire should run from the machine to an independent earthing rod
- machines should be tested annually for their electrical safety and checked that their insulation is intact
- portable tools like cutting machines and equipment should be double-insulated and earthed
- be certain that the electrical power can be shut off immediately in case of emergency; the main power switch should be within easy reach and clearly marked; all other switches should be clearly labelled as to what they control
- check that all workers know how to switch on and off the main power supply; be sure that recently recruited workers are also trained for emergencies.
- once the person is clear of the power source, be prepared to administer mouth-to-mouth resuscitation or cardio-pulmonary resuscitation. Training on these techniques is available at most hospitals or paramedical services.

Summary

Rules for making your premises a better place to work

Emergency action

Everyone should know how to help a person suffering an electric shock:

- turn off the power and remove the person from the source
 - if the switch is not accessible, find a long, dry, clean, non-conducting object to remove the person from the power source or the source from the person; beware of this operation; it is very dangerous.
1. Protect your factory from outside heat and cold.
 2. Let nature help you.
 3. Improve the heat reflection of the walls and roof.
 4. Improve heat insulation.
 5. Use shades to protect against heat from the sun.
 6. Let natural air-flow improve ventilation.
 7. Make better use of horizontal air-flow.
 8. Utilize the tendency of hot air to rise.
 9. Improve your floor surface.
 10. Build flexibility and adaptability into your plant layout.
 11. Prevent fires and electrical accidents.

7

Effective work organization

Improving organization of work processes is the best way to increase productivity, especially since it can be achieved with little or no capital investment. If you have followed the advice in the previous chapter, you will have established many of the preconditions for efficient organization. When you have reached this stage you can consider more advanced improvements.

Not all the ideas suggested in this chapter can be implemented immediately. Changing the design of machines and products, or the layout of the shop-floor, can be expensive and time-consuming. There are, however, a number of ideas which can be set up immediately with little or no cost, such as changing work assignments. You can start with these ideas and work towards the others over a longer period.

Some of the ideas you will find in this chapter may seem “soft” on workers. You may be used to the idea that only strict supervision and strong pressure give good results. Remember that supervision is expensive and that workers, however much they need their jobs, are not fools. They would rather work well for a boss they respect and admire and who treats them fairly.

On the other hand, do not fall into the trap of thinking that being nice to workers is sufficient. Efficient work is difficult to plan and design. You will need to think hard about products, machines, work flows and job assignments.

The benefits of better organization do not always show up immediately. New procedures and work practices take time for workers to learn. Adjustments may be necessary before the new system starts to work. There can be a “dip” in productivity when organizational changes are introduced, followed by a strong improvement if they are done well. While Chapter 10 will assist you in implementing change and offers several procedures for involving workers in the process of that change, Section 1 in Part 2 will assist you in assessing the impact of changes on productivity.

Let us first discuss some simple ideas which can have a strong impact on productivity.

Eliminate extra tasks and operations

Each work operation is a cost – it takes space, machine- and operator-time and energy. Your first step should therefore be to examine critically every production task and operation. In doing this, ask yourself whether the task or operation is really needed. Can it be eliminated altogether? Can it be changed or simplified? Can it be performed in combination with other tasks and operations?

You can eliminate or rearrange tasks by:

- introducing changes into the design of the product
- switching to new production methods
- performing a number of tasks in one operation by using special multi-task machines.

Additional tasks and operations are those that do not add value to the product or service. These incur costs for the enterprise but are not paid by the customers.

To achieve an efficient and effective production operation, consider the following guidelines:

- identify tasks and operations that do not add value to the product or service. These are, for example, delays caused by machine breakdowns, incomplete raw materials, looking for missing jigs and parts, “dead” production time due to blocked passageways, unnecessary transportation of materials from one operation to another, and excess reworks caused by lack of understanding of the task
- assess the effect of removing the non-value-adding task or operation from the production process
- determine the best way to improve the task; some tasks can be eliminated, combined with other tasks, simplified or changed
- apply the improvement.

The workers can help you to identify the main extra tasks and operations. Others may require a detailed analysis. You may also involve workers in planning how to eliminate additional tasks and in implementing new lean production processes.

Defeat monotony to keep workers alert and productive

In garment production, many operations are simple and repetitive. Usually, workers have limited skills and do the same tasks every day. While this practice makes workers experts in their particular tasks and improves productivity, it creates monotony; monotony and lack of variety can cause burden and fatigue. Repetition of the same movements can result in muscle strain and general stress. Attention wanders, quality suffers and the worker needs to stop the machine and recover. The result is low efficiency and negative work attitudes.

Operations that require repetitive movements that result in worker fatigue and muscle strain require an extensive investigation into the workplace and methods used with the aim of improving work quality and efficiency. Some simple steps to defeat monotony include the following:

- **Introduce frequent changes in tasks to stimulate the worker's attention.** Each job has a variety of movements which use different muscle groups. Possible changes include the production of different garment designs and varying colours.
- **Rotate workers to different workstations.** This will require training workers in several tasks and operations, including quality control, which will be helpful in the event of absenteeism. Most important, this will lead to a multiskilled workforce.
- **Create opportunities to change from sitting/standing or from standing/sitting working postures.** Provide appropriate work tables, chairs and stools. (See Chapter 3.)
- **Allow frequent short breaks.** No one can keep perfect attention for a long time and when attention drops, mistakes are made. Breaks help overcome this problem. Jobs which are repetitive, fast paced, or demand close attention to quality will be done much more productively with frequent short breaks. These breaks can also be an opportunity to move around and exercise.
- **Pipe in music.** This helps in breaking the boredom. Music stimulates the workers without interrupting their work. It is specially effective during the half-hour before lunch and at the end of the working day.

Install planned buffers to make the work flow smoothly

Buffer stocks are small supplies of goods placed before and after each machine or workstation. In machine-paced assembly-line work, like garment production, the use of

buffer stocks helps to make the work flow smoothly. This will reduce delays caused by workers waiting for the next work-piece. You have to take note, however, of the bundle tickets to prevent mixing the parts and off-shading. If a small stock can be built after the workstation, the next worker will not have to wait either.¹

The type, design and capacity of the buffer depends on product design, work-pace variations, space available, etc. In the case of small items, simple bins are usually sufficient. For bigger garments, special movable racks or containers should be made available (see Chapter 2).

In designing buffers you should try to:

- minimize the floor space taken up by the buffer
- ensure easy maintenance, transport and replacement
- choose the appropriate height for the buffer and design it to minimize the effort needed to put stock in or take it out
- store work-pieces in a systematic manner so you easily see what is available.

When buffer stocks are present, workers can build up a small advance which they can use to rest for a few seconds or correct machine settings. Buffer stocks help to make production continuous and, although a simple idea, they are used in most modern production systems. However, remember that having buffers does not mean having huge piles of work-in-progress at both sides of each workstation.

Ensure work-in-progress is under control

The introduction of various style changes into the production process requires tight management controls of both the raw material inventory and work-in-progress. Very often the preparation and identification of garment parts to be processed pose problems. Whether work is organized in single units or bundles of 20 to 100 units, the work flow has to be controlled well. The main options for transporting single units or bundles are:

- by the supervisor or a worker, manually
- in boxes, using manual or motorized carts or conveyors
- by overhead conveyors, manual or motorized.

In all cases, it is better to have sufficient units at each workstation but avoiding having excess stocks lying idle on the shop floor.

It is normal practice in bundle systems to organize the work flow to provide each worker with a minimum of two bundles of work-in-progress, one being sewn and one waiting.

¹It is important that stock balancing and line balancing is carried out on a daily basis. Labour skills and performances, machines and stock available are balanced to produce good work flow.

The simplest method of controlling work-in-progress is to have a large number on each bundle/box. The work-in-progress can then be loaded and manufactured in sequence. This ensures that styles and sizes are manufactured following the production plan to match the customer order.

The Kanban method

Kanban is a very simple technique which is designed to help cope with material flows throughout the manufacturing process. The basis of the approach is a Kanban card, which displays information relevant to the unit or the bundle it accompanies. Such information may include:

- quantity of components making up one Kanban
- component identity number
- process flow information (i.e. source, destination, etc.)
- processing description.

Kanban cards are often fixed to a box, which contains the parts in question and may also be referred to as the Kanban. When such box arrives at a workstation, the operator carries out the prescribed action on all of the parts within the box. Once the worker has completed the tasks, the processed units are placed back in another Kanban, ready to go to another processing station (see figure 1). The empty Kanban is now a signal to the system that this workstation requires more work. In a simple flow system, it may be returned to the previous station, where it will be refilled with more work and brought back, ready for processing.

This method of signalling can be extended throughout the entire production cycle, so that empty spaces on a finished-garments shelf should indicate the need to complete more garments, which in turn triggers the preparation of more material to be processed, the release of raw materials and the purchasing of new stock. This system helps to keep stock both on the shop floor and in

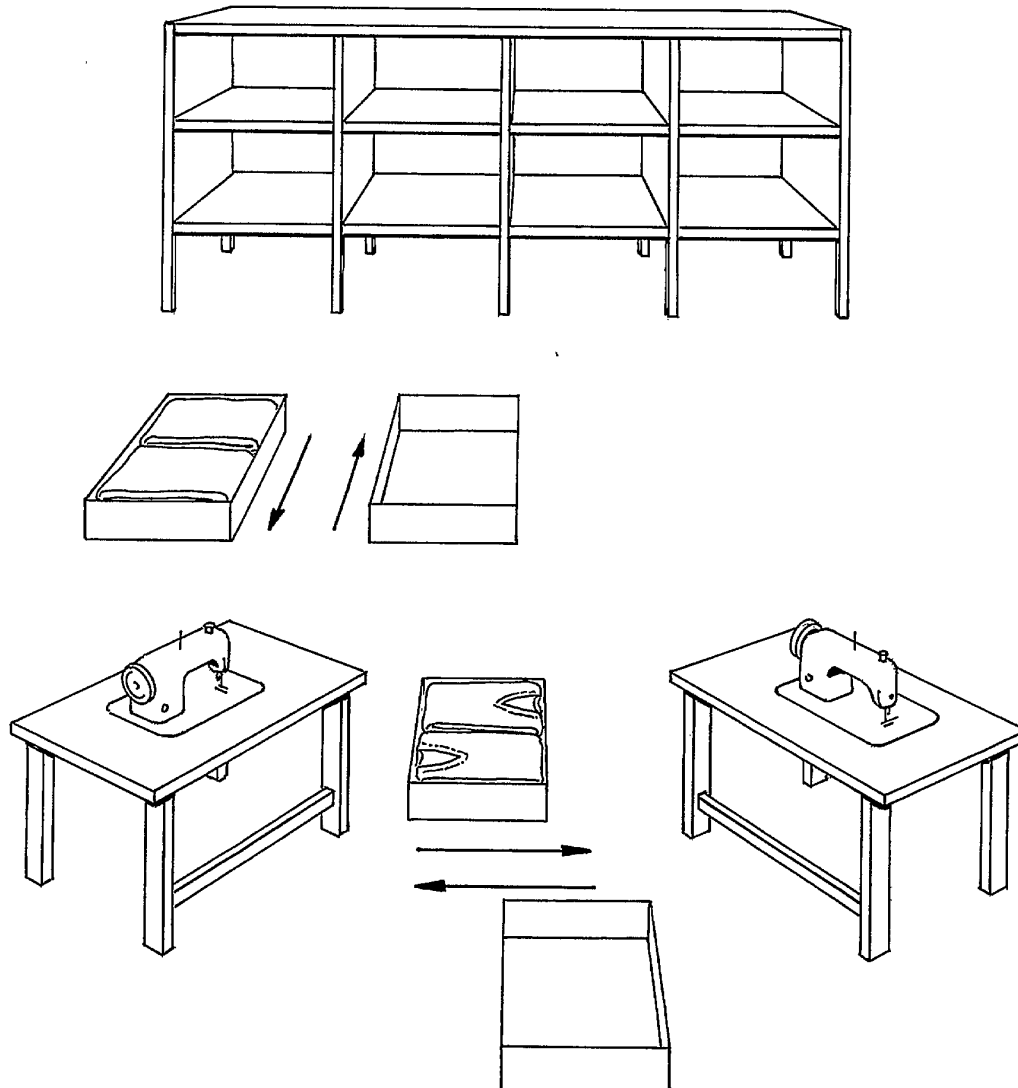

Figure 1: The Kanban concept

stores at a manageable level, thus making the production status more clearly visible and helping to reduce working capital.

The introduction of the Kanban system requires some planning and preparatory steps. An easy, low-cost way of introducing the Kanban technique is through simulation of part of the production process using a manual method. You will find the procedure for this simulation exercise in Section 3 of Part 2.

Provide adequate training and retraining

Adequate integration and training of new workers is essential to ensure best production practices, proper use of machinery, control of waste, safety and health, and commitment. All these will lead to consistent quality production and higher productivity. Your training strategy should be designed to allow workers to learn quickly and become adapted to both the culture and the technology of your enterprise. Training stages should include induction training (company awareness), basic training (quality requirements) and advance training (quality, dexterity skills).

Small enterprises offer excellent opportunities for new starters to quickly become adapted and feel comfortable. You can help improve their easy integration by following these simple and low-cost guidelines:

- ensure new workers are welcomed on the first day by management and introduce them to supervisors and fellow workers
- allow beginners time to familiarize themselves with the enterprise environment
- organize a visit to the production area and to other premises
- allow newcomers to choose a locker and provide, if necessary, suitable working clothes;

Similarly, you may help novice workers to reach their full daily production quota by:

- assign a suitable time for them to become familiar with the equipment and tools to be used and to learn about the technical details of their jobs
- organize a fluid exchange of information with experienced workers, particularly those who show an open attitude to newcomers
- include training on quality control and maintenance skills
- show samples of both good and bad quality products and encourage discussions on how to overcome production errors
- fix a daily production quota below the standard (avoid the "do what you can" message).

Remember that retraining may be necessary if you decide to introduce job rotation or job enlargement and enrichment techniques. For example, to introduce group work you will need multi-skilled workers as team members.

Design responsible, flexible jobs

Look around: your workers are all different in ability. One may be quick but error prone, another may be slow but precise; one may like to learn new skills, while another avoids any changes. The physical capacities of individuals also differ to a considerable degree. It is obvious that there is no "average worker". Nonetheless, we continue to design work for the "average worker". As a result, one part of the workforce is under constant strain as their capacity is lower than "average" and we have low quality, work interruptions and absenteeism. Others are under-utilized as their capacities exceed the "average". The following two rules will help in designing more productive jobs.

Specify individual tasks and responsibilities

Poorly organized work leads to many lost opportunities and extra costs whereas careful organization offers many benefits. Here are some points to follow:

- everyone should be clear who is responsible for output and quality
- workers should be helped to develop skills and become interchangeable in jobs
- workers should be fully occupied within their capability.

The first practical way of fulfilling these three points is to create a job description for each worker. Workers perform better if they know what is expected from them and if they have the necessary skills to meet the requirements. They should be given a clear understanding of what to do in certain situations: what can be addressed at his/her level and what should be put to management for solution.

Combine production operations and tasks

Another practical way of creating more interesting and productive jobs is to combine some production operations. This means that some workers are responsible for several operations of the same or similar nature. If you combine a sufficient number of operations, workers will be responsible for the greater part of a garment and the total quality of the product. Combining "like" operations motivates workers by making them feel individually responsible for a significant piece of work, rather than just a single fragmented task. Remember that the emphasis should first be on "like" operations.

In the garment industry, particularly in small jobbing shops, there are many opportunities for combining some production tasks. Cutting pieces of cloth could be combined with preparing or matching garment parts in

bundles. In the sewing production lines, for example, sewers can be trained on more than one operation, seam profile and machine. Some ironing or finishing tasks may be combined with folding ones; wrapping and packing tasks could easily be carried out by the same workers.

Combining tasks also helps to develop new skills. A small enterprise can hardly afford a high level of specialization of skilled workers. Unexpected absences of repair-workers or quality control specialists can result in production stoppages or shipment of a defective garment to the customer. For instance, if each worker is responsible for checking the quality of inputs to his or her workstation, he or she will not waste time working on already faulty garments.

Many enterprises train their workers to both machine and inspect their own work. Again, the operative word is "train". Remember: untrained workers without supervision will produce inconsistent quality standards. Small and medium-sized enterprises who have trained their workers to perform both operations, still have quality control inspectors and final examiners. In a "jobbing shop" this function may be the responsibility of the production supervisor and packer.

Combining operations and tasks is also the first step towards the introduction of more advanced forms of work organization, i.e. group work.

To develop your workers' skills, you may consider the following:

- increasing the interchangeability of machine operators by providing possibilities for them to acquire multiple skills and by encouraging occasional job rotation to keep skills alive
- reducing the dependency of machine operators on maintenance specialists or others carrying out auxiliary functions by assigning to them, partially or in full, the following functions: basic maintenance of sewing machines or other equipment; handling of materials or garment parts near their workstation; inventory work and quality control operations. The creation of multi-skilled workers depends on a number of factors: the workers' attitudes and openness to learn new skills, the difficulty and time available for setting-up operations, the degree of rigidity in other production tasks and the need for special auxiliary equipment, are but a few
- reducing the cost of constant supervision and thereby increasing motivation by giving to trained workers the opportunity to decide how work should be organized (for example, setting up the workplace, choosing their own methods); by providing on-the-job training through gradually increasing the level of difficulty of operations and tasks; and by letting trained workers share their experience and knowledge with others by making them responsible for training less-experienced workers.

In some cases, you may want to allow each worker to decide when to start and finish work and when to take a break, provided that the work quota is fulfilled or total hours of work are completed.

In some cases, in order to introduce some of the job enlargement suggestions discussed above, the production process may need partial reorganization.

Set up semi-autonomous groups to improve efficiency and reduce supervisory cost

So far we have been dealing with work assignments of individual workers. Designing each individual job is a complicated and time-consuming task. Are there ways to avoid it altogether? Many companies around the world find it feasible and beneficial to assign work to groups instead of individuals. You may already be doing this in certain cases.

Such group-work assignments have several advantages:

- it is much easier and less time-consuming to design goals and set tasks for a group than for an individual;
- the work flows more smoothly and less supervision is needed
- it could take less time for new trainees with previous experience to learn new skills, and provide a better opportunity for acquiring multi-skills
- continuous cooperation between workers helps them to spot mistakes more promptly, makes it easier to improve production methods and to eliminate unnecessary work.

Many of the most advanced large companies and some smaller enterprises have introduced group work and experienced very large productivity increases. They have established that groups work faster and better than the same number of separate individuals, even when the latter are backed up by extra supervisors and work-study experts. They have also learned that quality circles and other schemes for motivating workers and improving work methods are much more effective when work is organized in groups. You could benefit from their experience. Consider the comparison in Table 1 of cost, productivity and quality of work between individual and group work.

One way to introduce group work is to replace a rigid conveyor line by "group workstations", with buffer stocks placed between them (figures 2 and 3).

The efficiency of group work depends very much on the individual's attitude towards work as well as on the "work climate" inside the group. Group members should have the right skills for the job and be able to work happily

Table 1: Comparison between individual and group work

Individual jobs

- The pace of work is restricted by the slowest job in the line. Bottlenecks must be overcome through intervention by a supervisor.
- A change of product means that someone must redesign all jobs.
- Absent workers, machine breakdowns, problems with raw materials, etc., require intervention by a supervisor, who must decide what each worker must do.
- Each worker learns how to do one job.
- Each worker is responsible only for his or her task. Delays, mistakes and other problems can be blamed on someone else.
- A separate supervisor receives a higher wage for overcoming problems, planning and assigning work, discipline and other tasks.
- Training costs on single operations are low and training periods are usually short.

Group work

- Workers can help to overcome bottlenecks by exchanging tasks and sharing work.
- Workers can work out a new arrangement by themselves.
- Workers can work out a new arrangement by themselves.
- Workers can become multi-skilled.
- The group is collectively responsible for productivity, quality and discipline.
- All these tasks can be handled by the group.
- Multiple operation training costs are high and training periods are longer than for single operations.

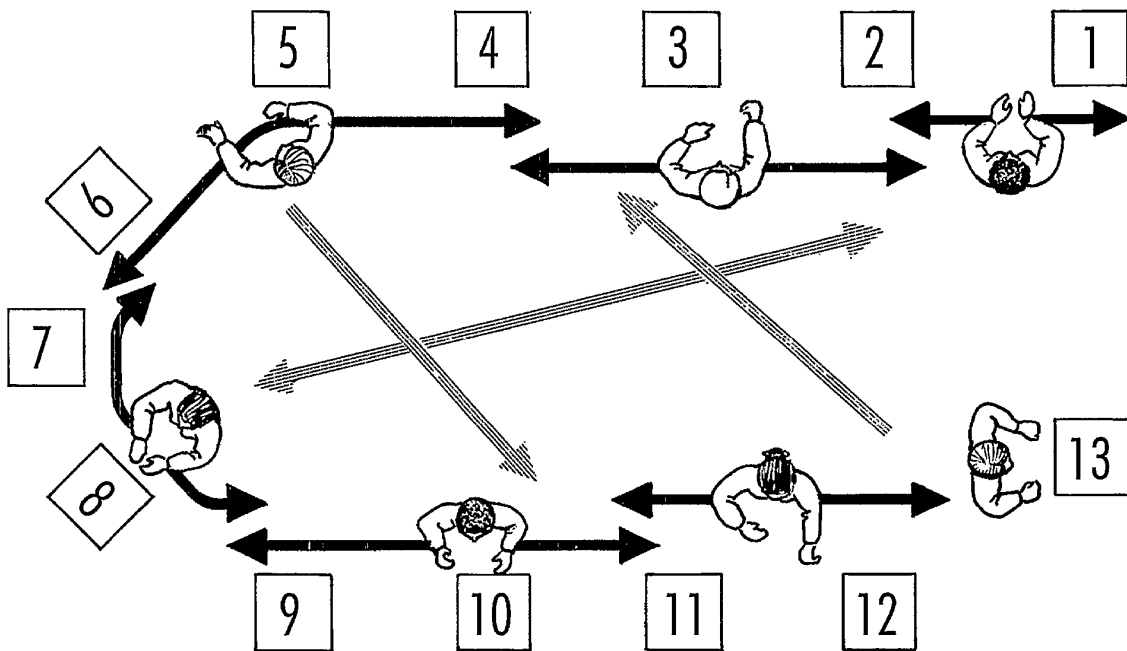

Figure 2: The Kanban system of team working. In this example, boxes of work are passed by hand between workstations. Workers move between jobs, either when there is no incoming work or the outgoing work position is full. Free movement within the group is encouraged (within agreed guidelines and priorities) - not just movement between consecutive operations. Usually set up for a "family" of styles

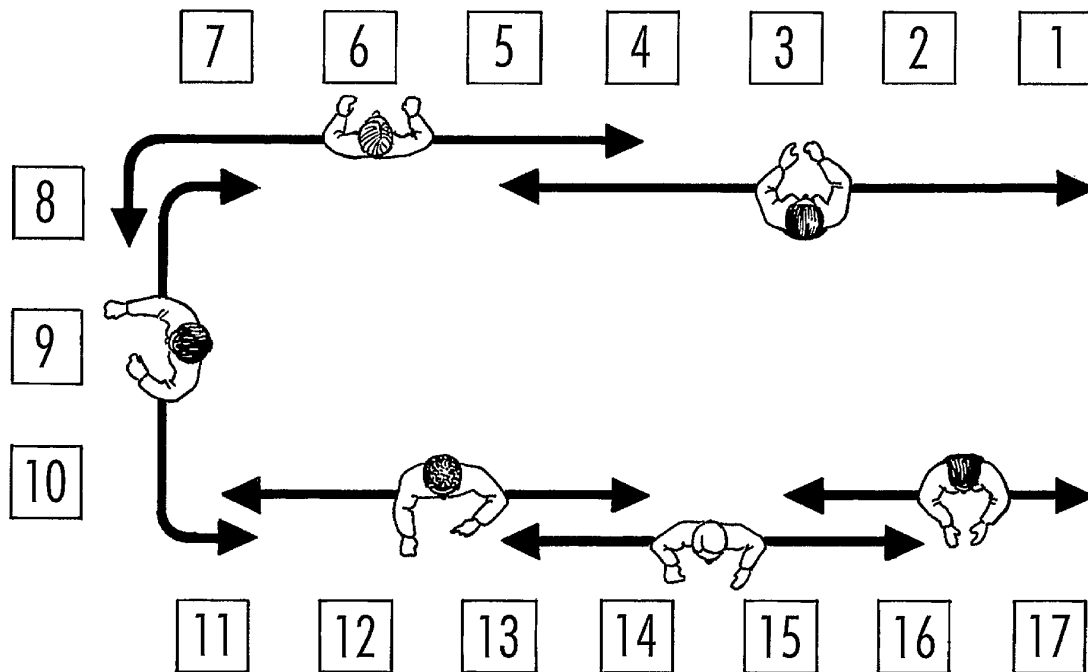

Figure 3: Another example of team-work known as the "Toyota system". Set up for one style at a time, workers stand and move to adjacent jobs. On completion of a task, each worker moves back to meet the previous one and takes over (often in mid-cycle of the particular operation). The aim of the concept is that a single garment does not stop moving and minimum throughput times can be achieved. The machines are usually on wheels for quick rearrangement of new styles

together. It is also important that groups are the right size. There should be sufficient workers to perform the task, but not too many (ideally four to eight).

Rewards should depend on the performance of the group as a whole and not on the performance of individual group members.

Links should be set up between the work group and any other groups who have information and/or expertise that the work group needs (for example, concerning supplies or maintenance).

Group members are in **control over the methods used** to perform the work, and the way the work is shared among the group members.

Members are given regular **information feedback** about the group performance. Displaying different group performances on an information board generates competition and, if managed and rewarded properly, can bring about a sustained productivity increase.

Semi-autonomous or autonomous working groups may represent a sound cultural change in the organization of your enterprise. It can take quite a long time to develop fully. When they are firmly established, they are very effective.

Arrange the production layout to meet enterprise objectives

Thus far we have discussed ways of improving efficiency at separate workstations and work areas. In order to attain full efficiency, we have to find the most appropriate way to link work together or, to put it another way, we need to select a general pattern of production flow.

In designing a plant layout, you have to consider the following factors: the type of product, volume of production, the equipment, process flow, materials flow, information flow, space requirement, safety, warehousing and service areas. In addition to these factors, the convenience of communication and flexibility should be considered. The ability to better respond to your customer's demand for quality, cost and delivery on time should be the end objective. Given that customers' demands change, any layout design will have a finite lifetime.

How can you organize your production to meet this objective? It can be done by redesigning work arrangements in such a way that:

- work flows in one direction for each product, so that its progress is readily visible

- everyone should be concerned not only with the quality of his or her own operation but with the total quality of the product
- there is regular and quick feedback between the customer and everyone engaged in production
- individual reward should depend not only on performance of a given task but on attaining a common final goal.

The main objective in good layout practice is to reduce or to eliminate the back-tracking of work. Work flows can be:

- straight line flow; or
- a "U" or circular flow.

The type of flow will depend on the:

- layout space available (can be on one floor and/or different floor levels)
- material-handling system employed (manual, semi-automatic or automatic)
- production flow start and end.

In enterprises where overhead conveyors or flat conveyors are used, work is fed to each workstation from the system. On overhead systems, the work continually moves in a circle. On flat conveyors the work moves back and forth from operation to operation and the work is manually loaded and unloaded by a conveyor operator.

The layout you adopt also affects the utilization of the following resources:

Human skills and talents

With an effective layout, human skills and talents can be improved since reduced walking and movement from one process to another will improve output. Delays caused by unclear aisles, for instance, reduce the opportunity for the worker to produce more.

Money

All manufacturing enterprises incur costs, both productive and non-productive. A properly designed layout repays initial investment by reducing the costs incurred by production delays, excessive material-handling and transportation, etc.

Machine operating hours

In sewing it is generally accepted that up to 60 per cent of the cycle time at the needle point is material-handling (excluding automatic and semi-automatic machines) leaving only about 40 per cent actual sewing time. Excessive movement of material and workers at the workplace can reduce the actual machining time

considerably, thereby contributing to additional non-productive time.

Material

Frequent manual handling of garments creates a greater danger of them being soiled or damaged. A well defined layout reduces this problem.

Time

Time is a limited resource and should therefore be managed and used properly. Poor layout affects material-handling and production operations which involve both worker-hours and machine-hours.

An appropriate plant layout will facilitate the production process. The following points should be considered in designing or redesigning the layout:

- assess current and predicted demand for your main products and style variations
- keep the transfer of raw materials and semi-finished goods between workstations to a minimum
- materials should flow logically – ideally, in only one direction. Avoid backtracking, as much as possible, from the start to finish of a production line
- where space is a constraint, make sure that the layout is well defined within that space
- have well-defined gangways between each production line, to facilitate the transportation of work
- properly labelled containers of different sizes and colours will assist in distinguishing the work from each line
- balance each production line to accommodate the various style variations to ensure good production flow
- provide small buffer stocks between each process or operator.

Precise line balancing is rarely possible; one can achieve between 90–95 per cent on average. In Section 4 of Part 2 you will find a basic procedure for line balancing.

Improve the sequencing of your production facilities

As pointed out in Chapter 2, the necessary displacement of workers for moving materials or pieces of garment from one place to another does not add any value to your production, just cost. If you have applied the checklist no. 1 to your facilities (see Section 2 of Part 2), it is likely that you have identified some improvements. Perhaps you have also introduced some minor changes to reduce handling distances with a view to improving the production process. To control unnecessary handling of materials, you may also use other methods like the string diagram, the travel chart and the weighted travel chart techniques. In Section 5 of Part 2 you will find a description of these techniques.

Choose the most appropriate layout

One of the important things to realize when choosing or designing a layout is that any design will have a limited lifetime. This is due to a number of factors:

- style changes and quantities
- variations in workers' performances
- shortage of work
- skill shortages.

As product mixes, volumes and garment designs change and with the introduction of new machines or technologies, the workload placed on each workstation will also change.

This is a very important factor to bear in mind when selecting a layout and implies that you may need to introduce different changes following new production requests. Consequently, there is no optimal layout that can serve forever and you have to be prepared for systematic change. Some of the following types of layout may suit your production needs. The main characteristics, advantages and disadvantages are pointed out in each case. Examine each of them carefully and see to what extent you can benefit from adopting any of them.

Bundle system with central storage

This production system requires work-in-progress to be collected from and returned to a central storage facility between operations (see figure 4). Its main characteristics are:

- heavy material-handling: needs a careful selection of containers (i.e. boxes, trays and carts) for holding and carrying bundles
- depending on the facility used for storage, long searching time for bundles may occur
- Whatever bundle method you employ, ensure that you have a visible, easy to identify, bundle system
- visual control is essential: the central storage facility should be easily seen from all angles to check availability or lack of work-in-progress.

Although this system may still be in use in some developing countries, it has some disadvantages vis-à-vis other systems and is no longer recommended.

Straight line system

A straight line production system is one where machines are set out in a fixed line, usually at both sides of a central table or conveyor (i.e. belt driven or overhead conveyor).

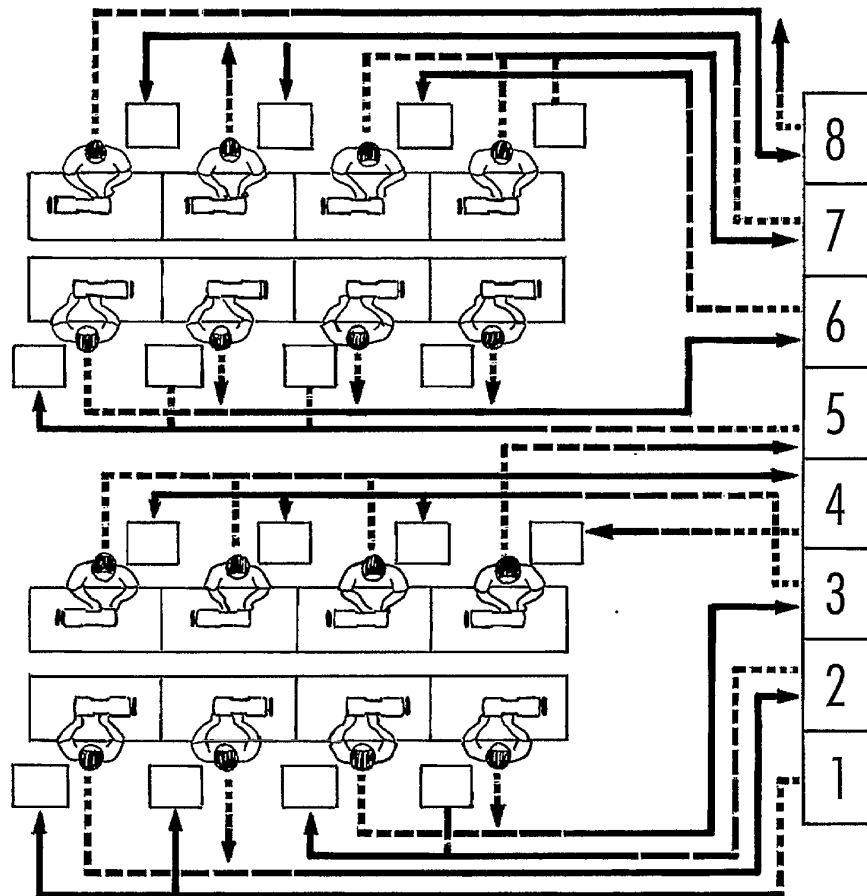

Figure 4: Layout of a conventional bundle system with a central multi-level storage rack

If a table is used, bundles are pushed by the operators to the next workstation. Set cycle-time conveyors are no longer used in the industry, because they were ineffective and were found to be too slow. Main characteristics of this system are:

- it is expensive to control
- it requires longer setting-up time when introducing new styles
- to be effective, it requires multi-skilled workers.

In figure 5, operations 1, 2 and 3 (not illustrated) are preparatory tasks carried out before work-in-progress enters the production line. In the example illustrated, two workers are performing the same operation 4 to ensure line balancing. Similar to the bundle system with central storage, described above, the straight line system is being replaced by other more flexible systems.

Progressive line (synchronized flow) system

A progressive line system is one where the workers pass their work from one operator to the next with buffer stocks, using appropriate racks, gravity (via chutes) or tilted tables (see figure 6). Other characteristics of this system are:

- line balancing is critical
- requires more storage space than the straight line system
- a space allocation of about 4m² per workstation is adequate.

Progressive bundle unit system

A progressive bundle unit system is a production system where the machines are laid out in the particular manufacturing sequence required for a specific garment. Bundles of work-in-progress are stocked in racks or receptacles between each operation. Workers on this system help themselves as and when they need it (see figure 7). Other characteristics are:

- line balancing is also critical
- work-in-progress stock is usually larger than with the progressive line system
- close supervision is necessary to keep production within the standard times
- suitable for the manufacture of a regular or large volume of products.

Interflow system

This is a production system which is set up to produce a wide variety of styles and products at the same time. Similar to the progressive bundle system, it has stocks of work-in-progress of each style between each operation. The system can be manually or automatically operated (figure 8). Other features are:

- characterized by work specialization, but movement of work-in-progress may not follow an established pattern
- material flow may be confusing
- special handling devices may be needed
- flexible, but requires multi-skilled workers.

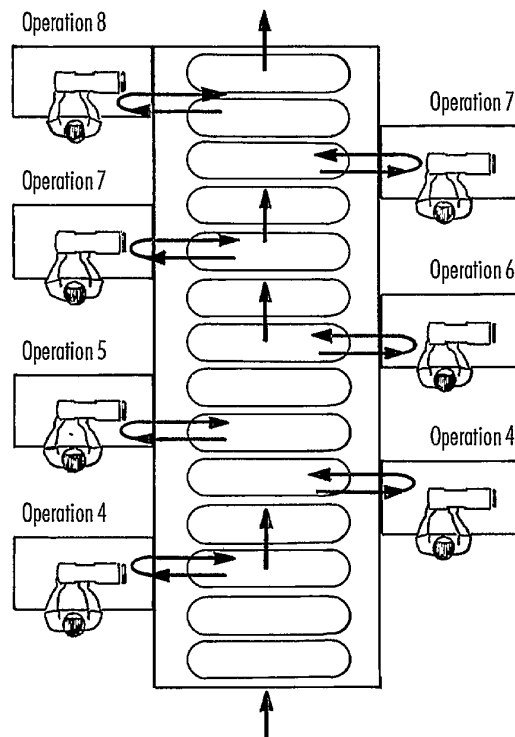

Figure 5: A straight line production system with a belt-driven conveyor. Operations 1, 2 and 3 are preparatory tasks (not shown)

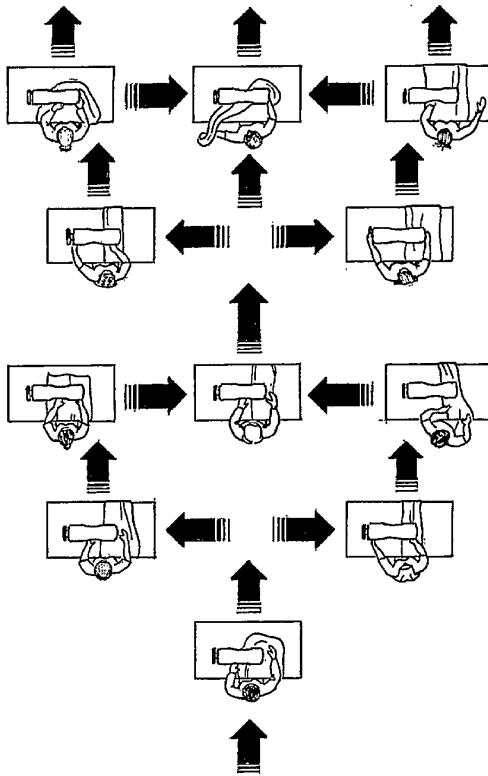

Figure 6: A progressive line production system.

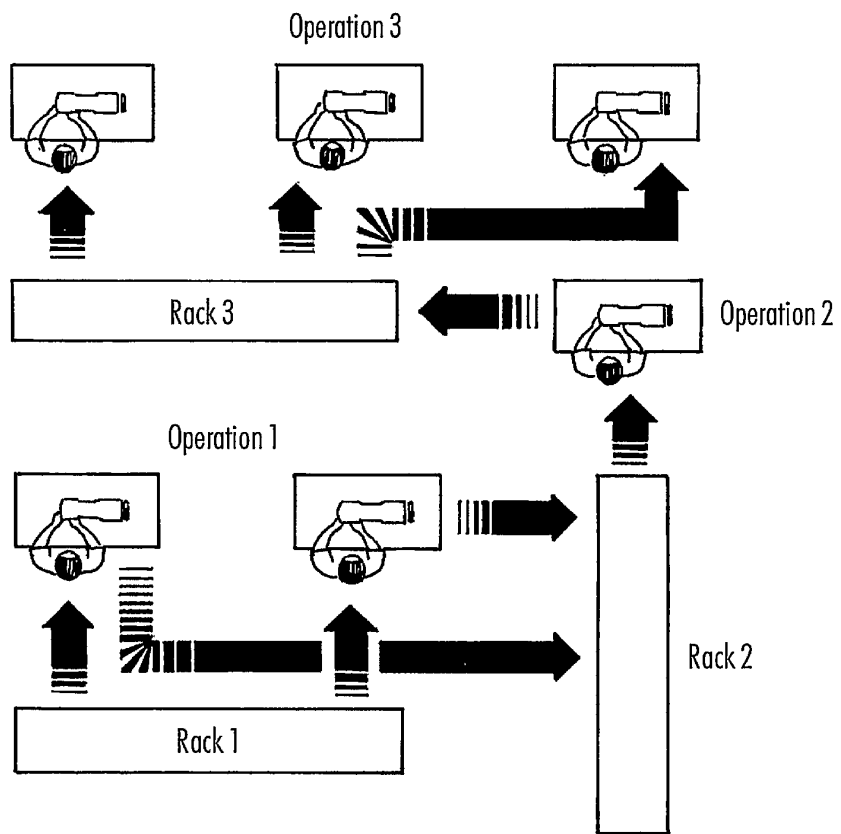

Figure 7: A progressive bundle production system set up for carrying out three consecutive operations

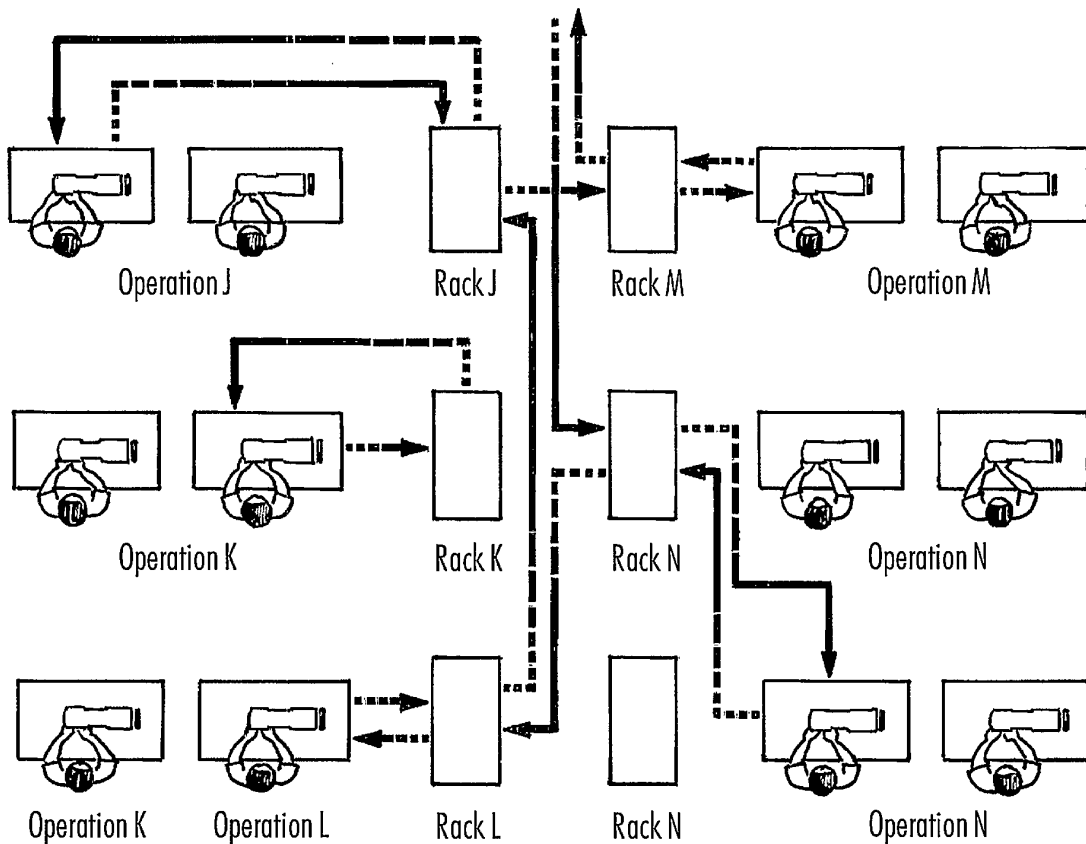

Figure 8: An interflow production system. Links between workstations and racks are represented for some processes only. Inputs enter and outputs leave the system from the top

Flexible flow system

This system allows manufacturing different styles simultaneously. Using only part of the system, single styles can also be manufactured. Depending on the number of styles processed, it requires a considerable quantity of racks and receptacles (figure 9). Other characteristics are:

- workers are multi-skilled and perform numerous operations
- suited for short runs
- common racks may serve different operations.

Remember: there is no ideal layout. The best layout is one that suits your own particular situation now. And the needs vary almost daily. Therefore, to make a good choice today, you have to consider all the factors discussed above and perhaps reconsider them tomorrow.

Set up a production progress control system

Whatever garments you are manufacturing, you will want to know the production status at all times. Of course you

can just walk down the workshop and check for yourself how the workers are doing; this may already be a regular procedure, but if you want your enterprise to be more competitive, you need an effective production control system. You should start from a system to check the overall scheduling of production, which will help you plan and adopt realistic schedules with realizable delivery dates. The basic rules are:

- know how long it takes for work to go through your workshop
- do not accept any orders with delivery less than this lead-time
- do not accept orders unless you have the capacity available to fulfil them within the required delivery date.

Some of the purposes of running a production control system are:

- to decide what jobs to start and when
- to know where each batch is and its condition, i.e. how much is good work, how much requires re-work, and how much has to be scrapped
- to see that the batches are moving through the processes on time and in sequence
- to predict when work will come out of the workshop.

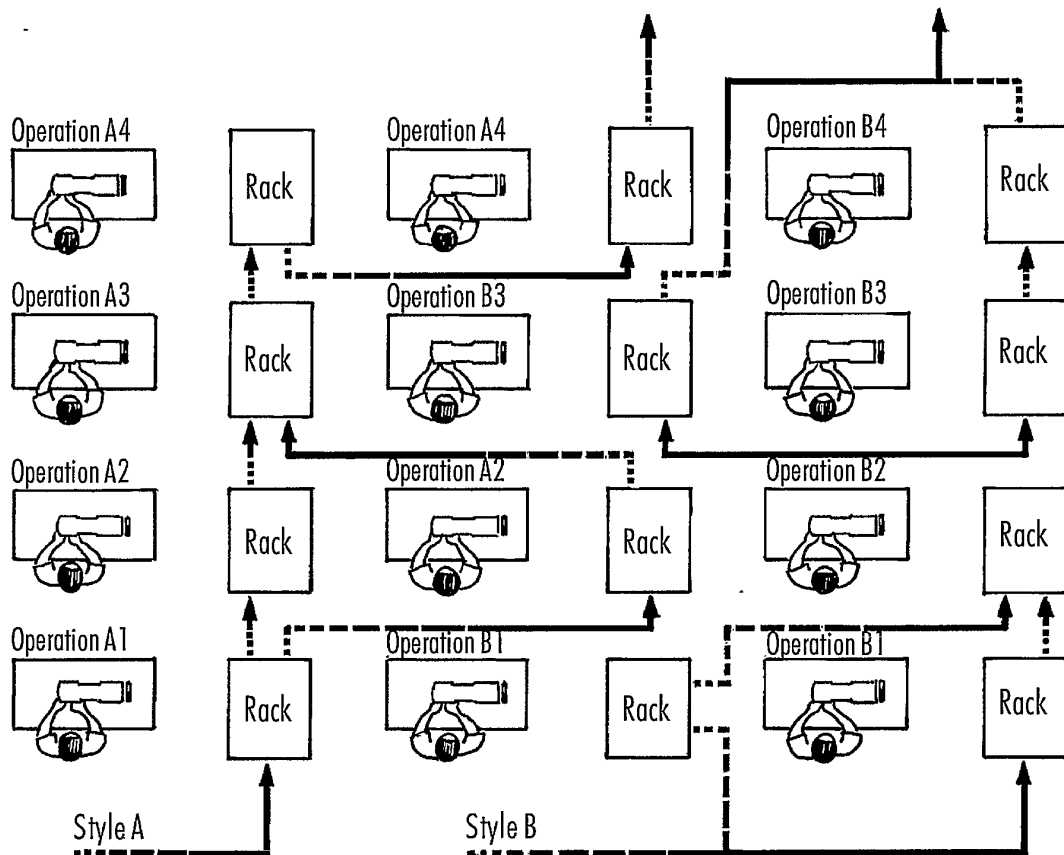

Figure 9: A flexible flow system serving two different styles

The main functions of a system controlling the progress of production are:

- to monitor production, if possible in real time
- to provide information for process improvements
- to meet delivery dates.

The system can vary from a simple blackboard showing the production status, to a fully integrated system of plant management and business information. Whatever the system, it must provide information on potential delays; delay is money doing nothing but it can also be a key to locating where difficulties in production arise.

Involving workers when setting-up and maintaining the system ensures that it will work. A systematic data collection will help monitor productivity by comparing production data from different periods.

Designing the system

The first thing you need to clarify is what benefit your enterprise will gain from a production control system. For this, you need to answer the following question:

- why is the data required?

Once you have a clear answer on this issue, you may start designing your system by answering these five other questions:

- what data is needed?
- when and how often should new data be available?
- where should it be made available?
- how will the data be used?
- who is going to use it?

Implementing the system

Once you have defined the main features of the system you can start designing and implementing it. The control of production processes can be introduced at different levels: the workplace, department and enterprise levels. Each will contribute by providing data on the status of production.

Start gathering very simple data; for example, use the production sheets to display, near the sewing-room, the daily production record. The progress of work can be checked by all involved by comparing regularly the planned production and the actual output. In this way, bottlenecks can be identified and work delays prevented.

With progress control, you can monitor individual production by knowing how far the work has progressed. This is very useful when checking the progress of trainees. For continuous production processes, you can monitor the quantity of products finished. The system may also enable you to monitor the location and quantity of work-in-progress in each production line.

The checking cycle and the checking method depend on the objectives of the progress control system. For individual or division/section outputs, checking may be done every one or two hours. Data is entered in the progress control board by the workers themselves or by the supervisor. The board should be located in a strategic place to provide quick and easy feedback to all workers concerned.

Figures 10, 11 and 12 show some examples of useful production control records. These will enable your enterprise to follow up the daily production for individuals, the progress made by different teams, or the output made by the entire factory. In cooperation with your workers you should develop your own tables adapted to your specific needs.

It should be noted that there are computerized systems that will help the off-line control of production progress from the level of any individual worker to the entire factory.

Remember: the key points for introducing a sustainable production control system are:

- define the purpose of the production control system with the workers;
- start collecting only the most useful data;
- provide immediate feedback; and
- involve the workers in the analysis of data for improvements.

Summary

Rules for work organization

1. Eliminate extra tasks and operations.
2. Defeat monotony to keep workers alert and productive.
3. Install planned buffers to help the smooth flow of work.
4. Ensure work-in-progress is under control.
5. Provide adequate training and retraining.
6. Design responsible, flexible jobs.
7. Set up semi-autonomous or autonomous groups to improve efficiency and cut supervisory costs.
8. Arrange the production layout to meet set objectives.
9. Set up a production progress control system.

The entries **10 am, 12 noon, 3 pm and End** in the **Time** row refer to the time when data is entered on the board, "End" being the time when work ended for the day (i.e. 5 pm). In this example, the enterprise starts work at 8 am and breaks for lunch from 12 noon to 1 pm. The first data is entered at 10 am and every two working hours thereafter.

Daily work flow shows the number of finished skirts. **Remaining quantity** is **Lot size minus Daily work flow**.

The **Input lot order** column shows the colour of the skirt in the production line; figures **7, 9 and 11** refer to the sizes being manufactured; **1,2,3,4 ... to 10** refer to the number of bundles; the figures "**10, 10, 10 ... to 5**" refer to the number of pieces per bundle. A bundle of 10 contains all the different parts needed for 10 pieces of skirts. The same part in a bundle could be interchanged because they are supposed to have been cut from the same roll of fabric. However, one should not mix parts from one bundle with those of another bundle because there could be colour off-shading and other problems.

In this example, the **Input lot order** column shows that there are 85 pieces of Size 7 Navy Blue Skirt and 100 pieces of Size 9 Navy Blue Skirt under production.

The board shows that for November 10, 11 and 12, bundles 1 to 9 of size 7; bundles 1 to 10 of size 9 and bundles 1 and 2 of size 11 for a total of 205 pieces are on the production floor. Ms B, however, exceeded the number. It is possible that she has started working on the part to be pleated of bundle 3 of size 11.

The **Progress control board** also shows that on November 10, Ms A sewed 200 pieces of the parts facing to the front. On November 11, Ms B runstitched the pleat of the part to be pleated of 209 skirts. On November 12, Ms C runstitched 200 linings of 200 skirts.

Figure 10: A model of a progress control board

Progress control board											
November 12											
Production number		173011		Target number of pieces produced per day				210		Remarks	
Product name		Skirt		Actual number of pieces produced per day				200		30 minute electricity cut	
Lot size		800 pieces		Actual number of workers				14		Two absent	
Name of worker	Time target	10 am	12 noon	3 pm	End	Date	Daily work flow	Remaining quantity	Input lot order		
		Colour: Navy Blue									
Process		45	90	150	210		100	700	Size	Bundle	Qty
Ms A	Sew facing to the front	40	80	145	200	10	175	525	7	1	10
										2	10
										3	10
										4	10
										5	10
										6	10
										7	10
										8	10
										9	5
										—	
85											
									9	1	10
										2	10
										3	10
										4	10
										5	10
										6	10
										7	10
										8	10
										9	10
										10	10
—											
100											
									11	1	10
										2	10
Ms B	Runstitch the pleat	46	90	153	209	11	203	322			
Ms C	Runstitch the lining	50	100	160	200	12					

8

Low-cost work-related welfare facilities and benefits

Work-related welfare facilities are often ignored. Who cares about toilets, first-aid kits, lunch rooms or lockers? What do they have to do with the hard realities of production?

One answer is that workers care. During each working day, workers need to drink water or some other beverage, eat meals and snacks, wash their hands, visit a lavatory, and rest to recover from fatigue. This can be difficult or easy, unpleasant or comfortable, a health risk or an aid to hygiene and nutrition. The essential facilities in your factory show whether you care about workers more than you care about your machines. Worker dissatisfaction can be costly.

Another good reason is that extra efforts for better facilities are often appreciated far beyond the time and money invested. Work-related facilities help workers to overcome problems which are important to them. Let workers express their priorities for improvements and ask them to take responsibility for the work which is required. You may be surprised at the results.

A small enterprise can be a community where workers are loyal, with good industrial relations and high morale. It can also be a place where workers look for the first opportunity to leave and care little about the owner's success. Which kind of enterprise do you want? The series of low-cost facilities that follows will help to retain the best workers.

Make sure essential facilities serve their purpose

Fatigue and disease are enemies of efficient work. Essential facilities are more than just a legal requirement. They can do much to reduce fatigue and maintain health. It is important that the quality of such basic facilities is high: otherwise they can spread disease instead of preventing it.

Drinking water

Drinking water is essential for all workers; if this is not provided, they become thirsty and gradually dehydrated. This greatly increases fatigue and lowers productivity, especially in a hot environment.

Place water containers near each group of workers, or provide taps or fountains with clean water in a central place. This will minimize the time lost in going to get a drink. However, drinking water should not be placed in washrooms or toilets, near dangerous machines or other hazards, nor in places where it can be contaminated by dust, chemicals or other substances.

If there is any doubt about contamination, water must be thoroughly boiled or properly filtered or treated. Before starting to use a new water source for drinking purposes, it is advisable to have it tested to make sure it conforms to the national standard for drinking water. The design, construction and operation of deep wells for the extraction of ground water should be subjected to the provisions of existing water codes. Piped water should only be used when a hygienic water supply is guaranteed. A clear distinction between potable and non-potable water taps should be made and a "Safe Drinking Water" sign should be put up near to each tap.

Drinking water vessels should be made from materials that can easily be cleaned. Even if the vessels are filled with fresh water, the water inside, if kept for even a short time, can become unhygienic. It should therefore be changed frequently.

It is also important to make sure that drinking water is cool. If a water cooler is too expensive, the water vessels can be placed in the coolest place in the factory. They should not be left uncovered, under the sun or in a hot place.

Drinking fountains for production areas are very advantageous from a hygienic point of view (figure 1). They can be fitted with a jet or bubbler outlet and/or goose-neck or other outlet for filling drinking cups. The fountain should be free from sharp angles and designed to prevent unnecessary splashing. Water outlets should be above the rim of overflow level so that they will not be contaminated with waste water. The water outlet should be shielded to prevent the lips of a drinker from being placed on it.

Drinking water containers should be attended by a designated person. Containers should be made of impermeable materials. A cooling device would be an

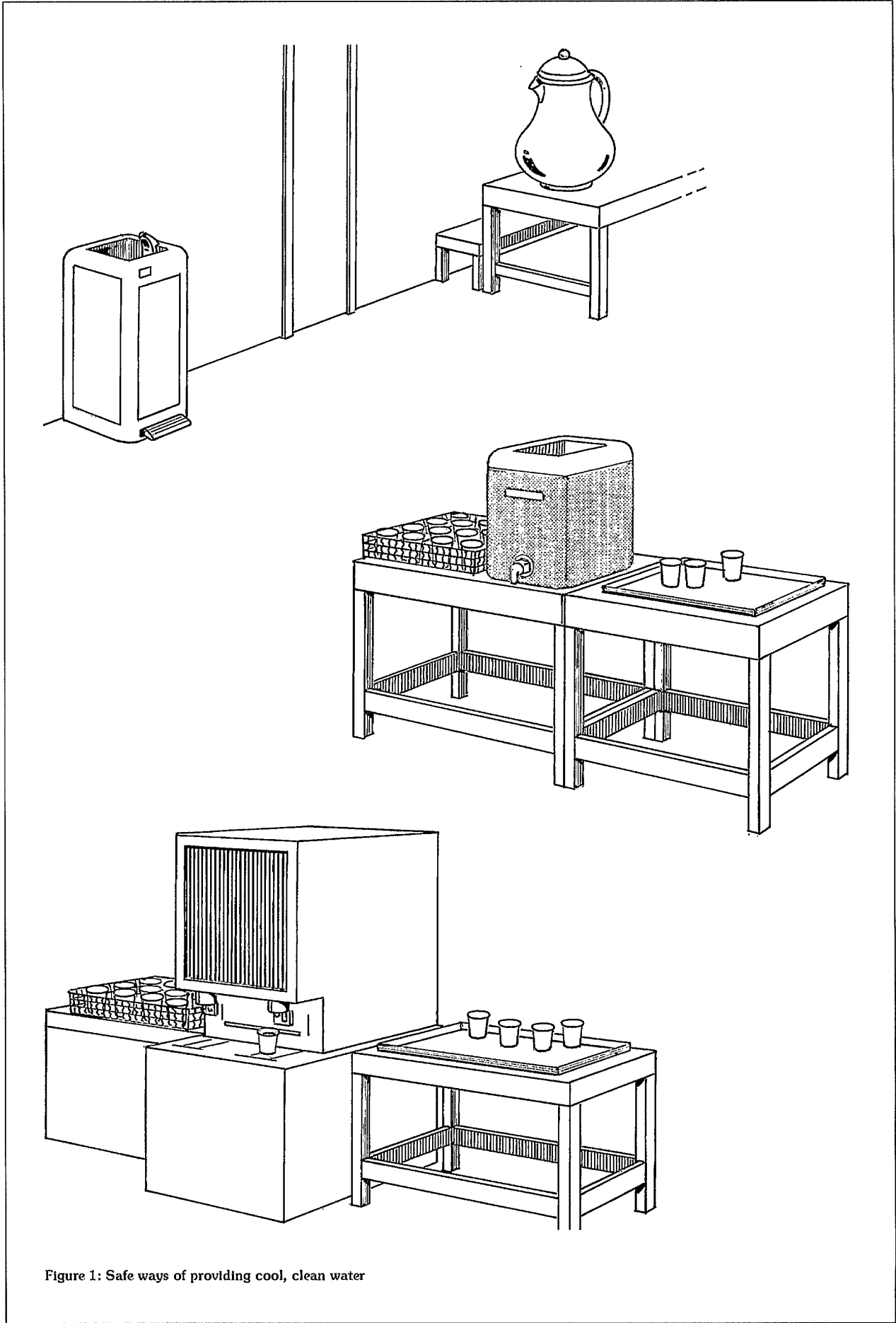

Figure 1: Safe ways of providing cool, clean water

advantage. (Unglazed pottery can be used, due to its unique cooling effect, in dust-free places.) Containers should be provided with suitable covers, and kept in a cool place protected from the sun. The water must be changed frequently.

To avoid the possible spread of infection, it is preferable to use disposable cups or to provide separate cups for each worker and to arrange for regular washing. When containers are used, it is important to clean them regularly. Cleaning and other necessary maintenance tasks should be assigned to a specific person.

In addition, the provision of a facility for boiling water will enable people to make coffee or other hot beverage during breaks. Hot water is required if the enterprise has a child-care facility.

Sanitary facilities

There are several reasons why the provision of washing facilities is important:

- dirt and grime can be ingested and cause sickness or disease; they are, in any case, unpleasant and demotivating
- washing is required for basic hygiene after using the toilet
- washing is a necessity when women have their monthly periods.

Apart from the obvious basic need, sanitary facilities are required by law. Customers often create an impression of an enterprise through the quality of its sanitary facilities (figure 2).

There should be a sufficient number of sanitary facilities on the premises and each should be conveniently located to avoid long walks, waiting and frustration. The law of your country must be followed, but the following are the minimum requirements:

- one toilet is required for up to five men; two toilets for six to 40 men
- one separate toilet for up to five women and two toilets for six to 30 women
- one wash-basin for every 15 workers.

Ideally, there would be a separate toilet for men and women. These should be characterized as follows:

- the toilet bowl must be free from stain or odour and function properly
- the walls of the toilet must be clean and tiles unstained
- the ceiling of the toilet must be free from cobwebs and dust
- floors must be clean and safe (no broken tiles, nor slippery surface)
- proper illumination must be provided inside the toilet
- toilets must have a continuous supply of water; in case water is limited in the area, water should be stocked in containers and refilled regularly

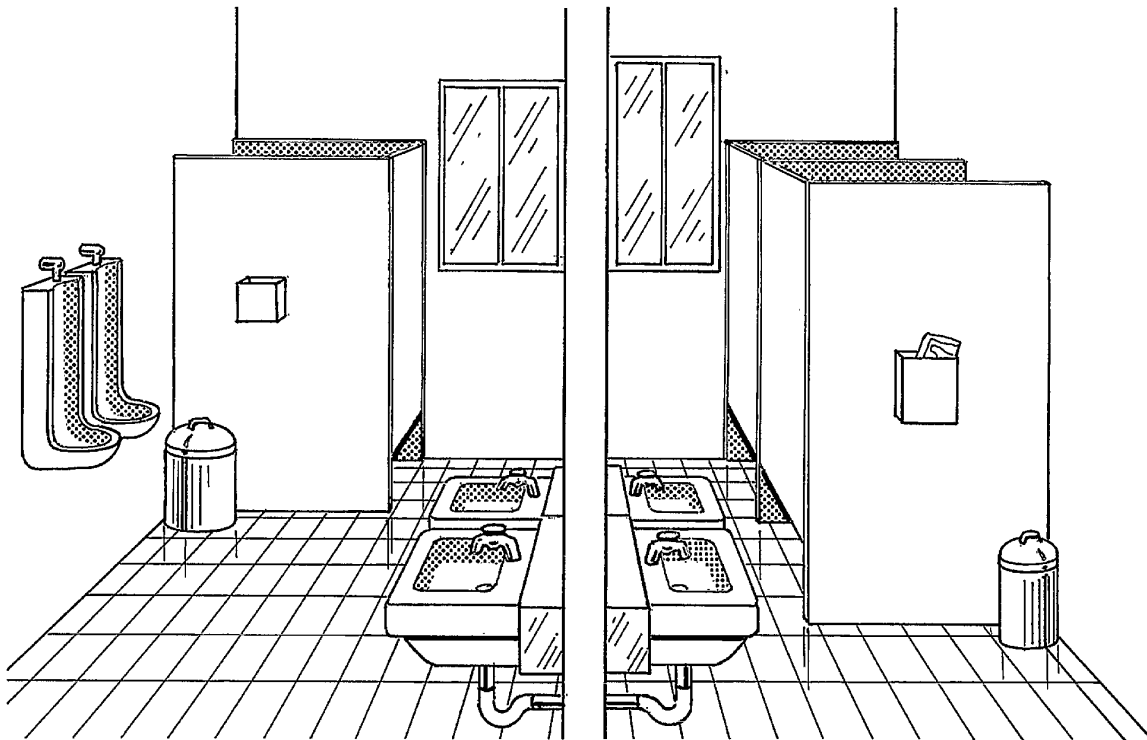

Figure 2: Toilets with wash-basins for men and women workers

- mirrors and rubbish bins should be provided in the washroom
- soap and toilet paper should be provided
- the washroom should provide complete privacy to users and should be fully ventilated.

Individual towels for workers should be provided. An alternative to towels is an electric hand dryer fixed to the wall. If you can afford it, sanitary napkins should be provided; otherwise, this item and other toiletries such as toothpaste, toothbrush, soap, lotions and other items should be offered for sale nearby or from a vending machine, if available.

The design of sanitary facilities makes a big difference in the cost and effort required for cleaning. Avoid wooden floors and difficult-to-reach corners. Provide proper drainage. It is best to use tiles for walls and floors, or at least to make sure that surfaces are smooth and easy to clean. If you do not use tiles, choose the paint carefully. Porcelain is best for washbasins, toilets and urinals.

Be ready for emergencies

Accidents can happen even if proper preventive measures are installed; so, always be prepared for emergencies, like cuts and bruises, eye injuries, burns, poisoning and electric shocks. Every enterprise, therefore, has to maintain a well-

stocked first-aid box and assign at least one person from every shift to handle emergencies.

First-aid boxes should be clearly marked and located so that they are readily accessible in an emergency (figure 3). They should not be more than 100 metres away from any place on the work site. Ideally, such kits should be near a wash-basin and in good lighting conditions. Their supplies need to be regularly checked and replenished. The contents of a first-aid box are often regulated by law, with variations according to the size and the likely industrial hazards of the enterprise. A typical **basic kit** may include the following items in a dustproof and waterproof box:

- **sterile bandages, pressure bandages, dressings** (gauze pads) and **slings**. These should be individually wrapped and placed in a dustproof box or bag. Sufficient quantities of the different sizes should be available at all times to treat small cuts and burns. Medical adhesive tapes (strip plaster) for fixing bandages and dressings are also needed
- **cotton wool** for cleaning wounds
- **scissors, tweezers** (for splinters) and **safety pins**
- an **eye bath** and **eye wash bottle**
- ready-to-use **antiseptic solution** and **cream**
- simple over-the-counter **medicines** such as aspirin and antacid
- a **booklet** or leaflet giving advice on first-aid treatment.

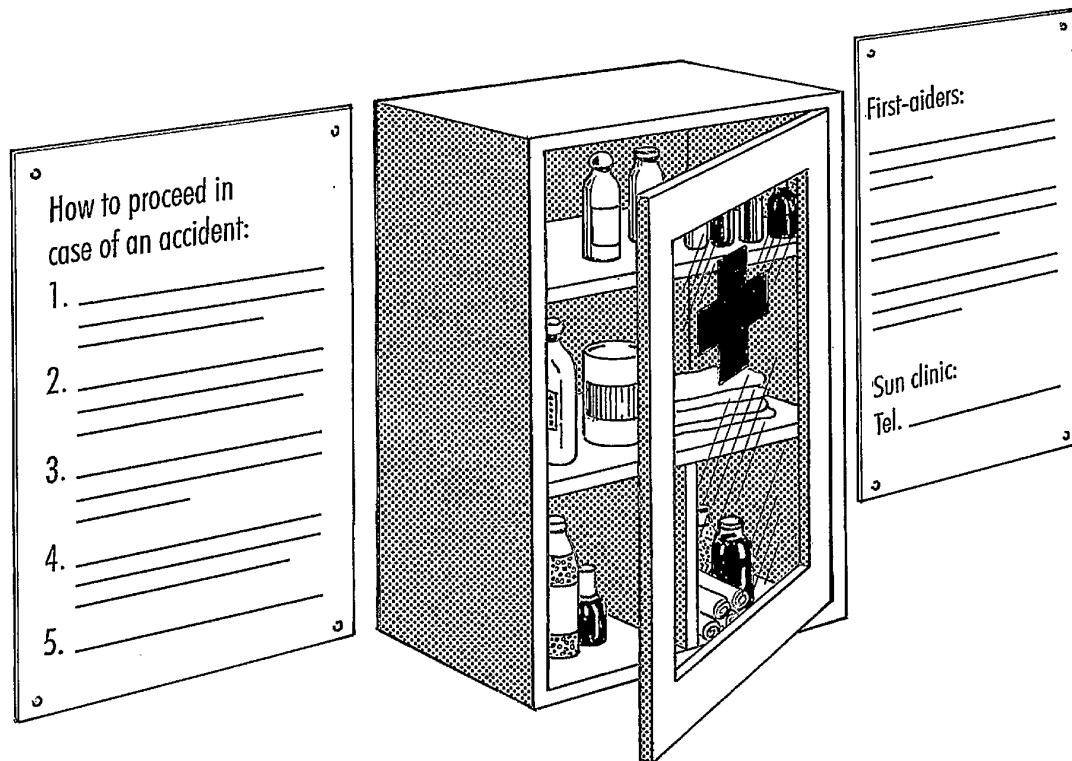

Figure 3: A basic first-aid box and first-aid instructions

First aid requires some training, but this is not difficult to arrange in most places. The names and location (including telephone number) of those responsible for first aid should be put on a notice board. Worker involvement, especially for emergency situations, is strongly advised and everyone should know the procedures for obtaining medical assistance.

Small establishments without their own facilities should keep contact with a nearby clinic or hospital, so that the time between the occurrence of an accident and medical assistance is very short, preferably much less than 30 minutes. Transport to the clinic or hospital should also be pre-arranged. An outside ambulance may be called in, if necessary. It is also desirable to have a stretcher available.

Make sure that rest means recovery

Rest breaks

Workers usually start the working day alert and productive, but their level of activity decreases as the day progresses. Fatigue grows gradually before it begins to have a strong effect. If the worker rests before he or she shows signs of being really tired, recovery is much faster. Short breaks taken frequently are much better than infrequent longer breaks. For most types of work, *productivity is higher with short breaks than with continuous work.*

Depending on the type of remuneration and incentive schemes, workers sometimes continue working until they feel very tired, so you should plan breaks. At least one ten-minute break in the morning and one in the afternoon, in addition to a longer break for lunch, are absolutely necessary. A five-minute break every hour, especially for monotonous high-speed work, is an excellent idea. Discuss with the workers how to organize breaks, while ensuring their daily production targets are achieved and the arrangement for the optimum use of available rest areas.

Rest areas

A good rest area also helps to reduce fatigue (figure 4). This will hasten the recovery of workers from fatigue and enable continued productive work. Getting away from a noisy, polluted or isolated workstation helps them to relax and recover from fatigue. Rest areas should therefore be away from the workstation and free from disturbances. A simple canopy outside the factory may provide a shady rest area, especially if there are plants and breezes. Avoid bright sunlight: the eyes need to rest as well as the body. Benches and a place to lie down should be provided. This is an effective way to recover one's energy. And if there are pregnant workers, the opportunity to lie down during breaks will prevent excessive swelling of their legs and feet due to the additional weight being carried, especially in the latter part of pregnancy.

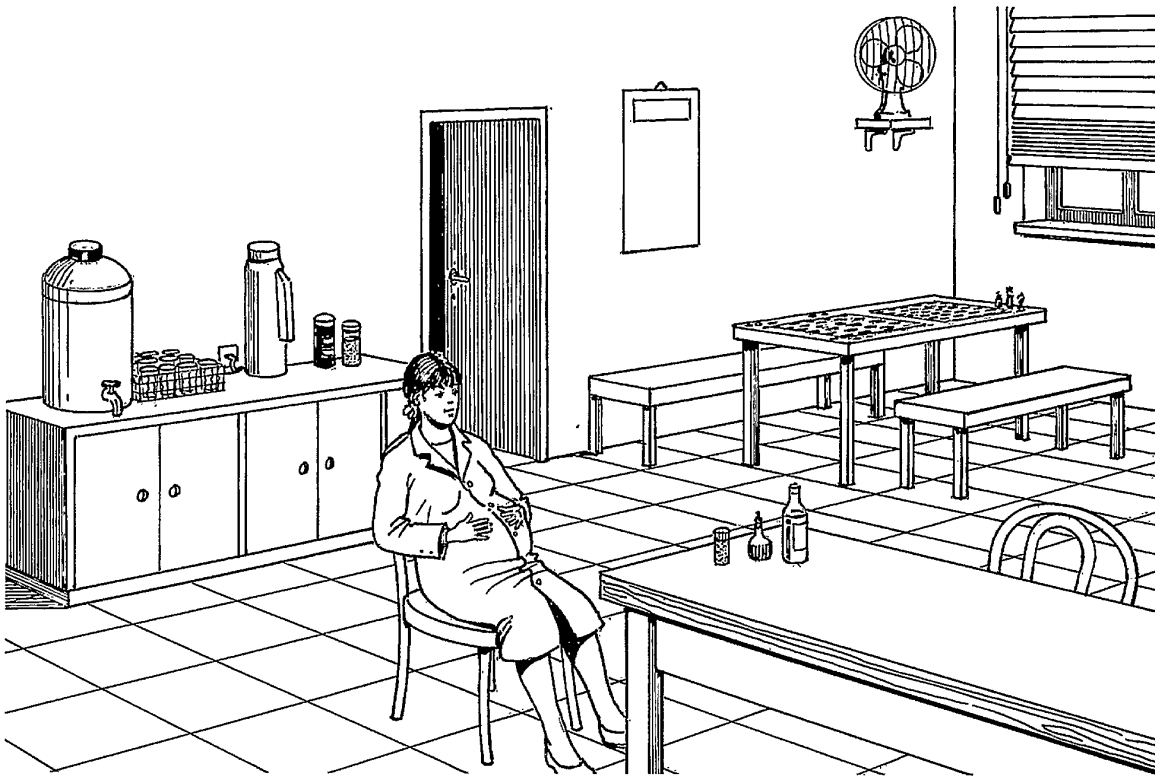

Figure 4: Rest areas for workers to lie down, relax or watch television during break time.

Use low-cost facilities to attract and retain the best workers

Smaller enterprises have a great deal of difficulty in competing for high-quality labour. A common complaint is that as soon as workers are fully trained, they leave for the higher pay and better benefits of larger enterprises. While in some cases this may be true, other workers attach greater value to the closeness and feeling of belonging in a small enterprise. It may be difficult to compete in terms of wages, but a great deal may be accomplished by paying attention to the needs of the workers. Treating workers as part of a family can gain their sustained cooperation and support.

All workers' needs vary. They may include meals, transport, work clothes, lockers or other work-related needs, or even an opportunity to practise sport after work. It is in these areas that, based on their needs and with their help, you can introduce some low-cost improvements, one at a time.

Work clothes

Work clothes may be provided to the workers. Neat and well-designed work uniforms decorated with the factory logo enhance the image of the enterprise and work commitment. T-shirts and peak caps are low-cost

resources for identifying workers in production teams or engaged in specific tasks, i.e., quality control, maintenance, etc.

Lockers and changing rooms

Facilities for secure storage of clothes and other personal belongings, such as lockable lockers and changing rooms, greatly assist workers with their personal hygiene, appearance and tidiness, and avoid anxiety about the theft of personal possessions. Protective gloves and dust masks can also be kept in lockers (figure 5).

Lockers or similar storage facilities should be located where they will not impede work or obstruct light or ventilation. This can be achieved by placing them near the entrance door or within changing rooms, or moving them as far as possible from the workstations.

Changing rooms are particularly important where workers have to change from street clothes to uniforms or protective clothing. Changing rooms should provide privacy to all workers, and a changing room must be provided for each sex. If the number of workers is so small that providing separate changing rooms would be too costly, management has to make sure that the common room is properly screened and secured.

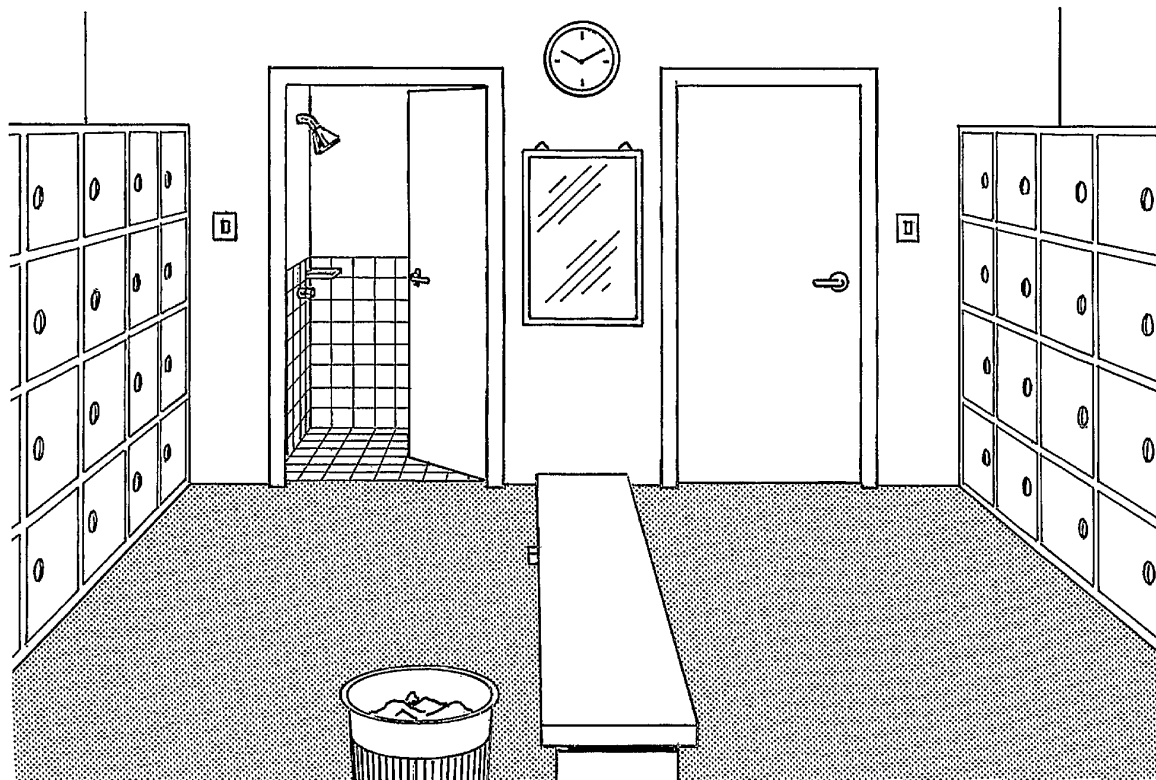

Figure 5: A changing room with lockers and showers

Washing facilities such as wash-basins or showers should be placed either inside the changing areas or close by. Combining dining and changing rooms in the same area is not recommended for reasons of hygiene.

Eating areas

Some smaller enterprises may not have the capital to provide a canteen immediately. The first low-cost step would be to provide an eating place or room in which the workers can eat their own packed lunch or food bought from vendors. This lunch-room could include a small area where workers can prepare drinks or heat their food. It should be situated away from the workstations to avoid any contact with dirt, dust or dangerous substances used during the work process and should be as comfortable as possible to enable workers to relax during meal-breaks. It is advisable to set up the eating room or area with future plans to upgrade to a small canteen at a later stage (figures 6 and 7).

Canteens

Establishing a proper canteen service is the best way of encouraging workers to eat sufficient nutritious food during a reasonable short break from work. It may not be feasible for workers to return home for meals due to distances involved, the high cost of transport, lack of commuting facilities or

simply because the meal break is not long enough. Other eating facilities near the workplace may also be unsuitable due to the high cost of meals, the poor hygienic conditions of some food stalls or the poor nutritional value of the food provided.

Different facilities may be provided, some of which can be quite inexpensive:

- a canteen serving only cooked or pre-cooked meals
- a buffet to serve packed meals, snacks and beverages
- facilities (including space, shelter, water and rubbish bins) for vendors to sell hot food
- a group restaurant jointly set up by a group of employers; or
- arrangements (i.e. luncheon tickets or other pre-paid system) with a restaurant or canteen near the enterprise.

It is most important to pay attention to hygienic conditions and the nutritional value of meals served. It may be a good idea to get advice on both from an expert.

The space needed for setting up a canteen is often less than you might expect. An eating place or room for 50 workers requires only 25 square metres, if the workers share the space by eating at different times.

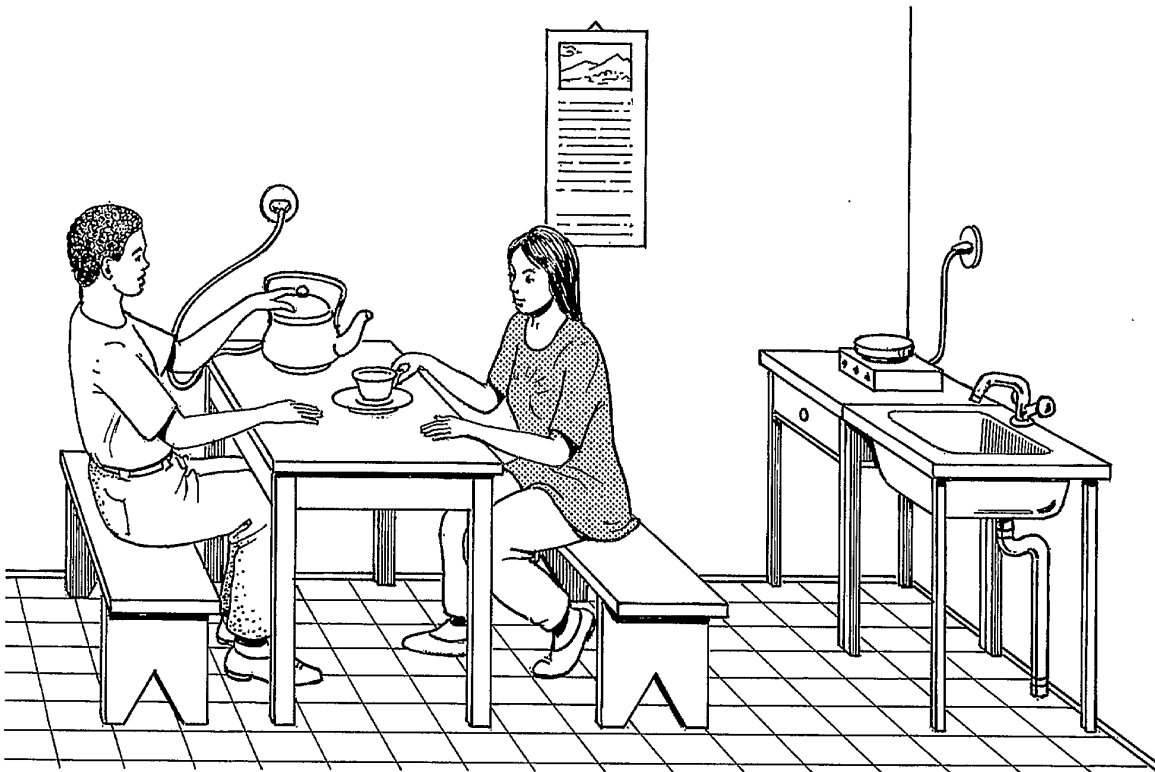

Figure 6: An eating place with simple cooking arrangements

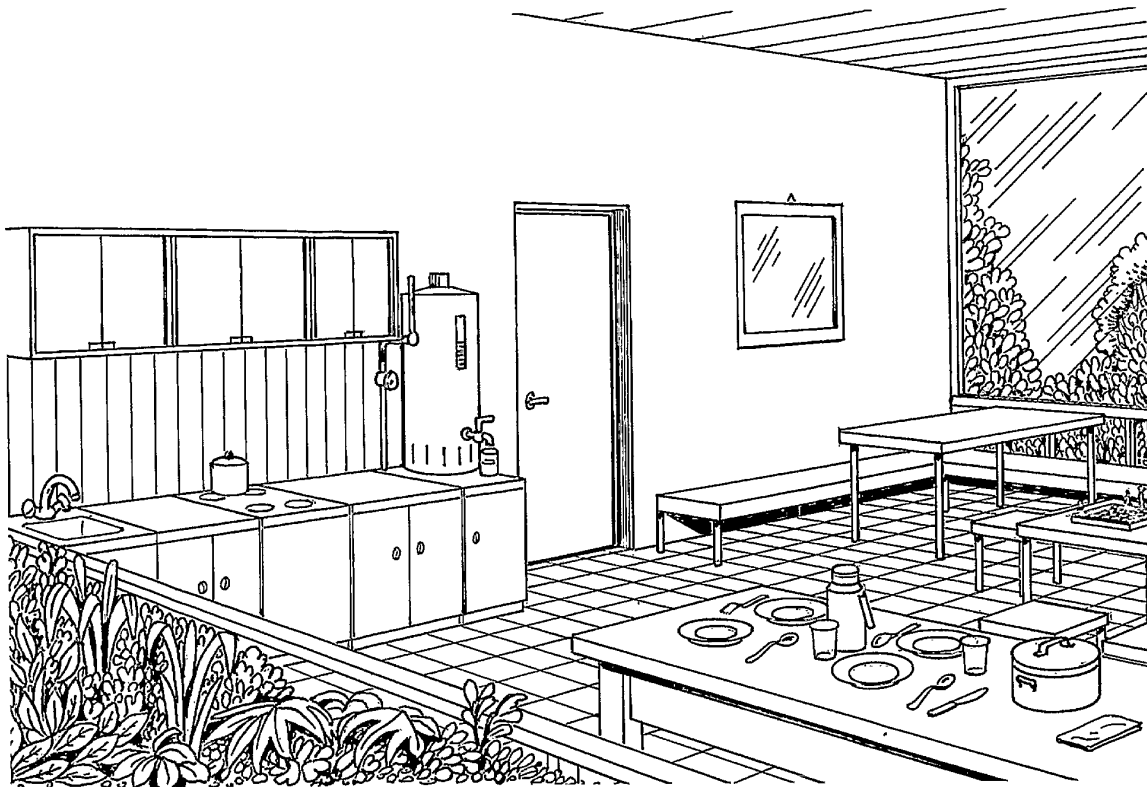

Figure 7: An eating place combined with a rest area

Health facilities

Although most countries try to provide access to health care for every citizen, services are often inadequate. You can help your workers by providing them with a workplace medical facility, such as a small clinic where treatment can be given for any occupational injuries and, in addition, provide some general health care (figure 8). This can help avoid delays, lateness and absence which may result from using local services. If your enterprise is too small to run a clinic alone, several enterprises may be able to establish such a service together. If not, you can still:

- arrange regular visits to your enterprise by a doctor or nurse
- provide treatment at a local hospital or clinic if a worker gets sick or has an accident
- assist in establishing a community health service near the workplace
- grant loans or salary advances to workers to help meet medical costs
- provide health insurance for all workers, or encourage workers to join private insurance schemes, by contributing to the premiums.

Transport facilities

Getting to and from the workplace can sometimes be difficult, lengthy and tiring. This, in turn, can cause fatigue, anxiety and financial hardship for the workers. It can result

in undue lateness, increased worker absenteeism, high labour turnover and, consequently, in declining efficiency of the enterprise.

Small-scale enterprises sometimes pay a transport allowance. If you are unable to do this, you could:

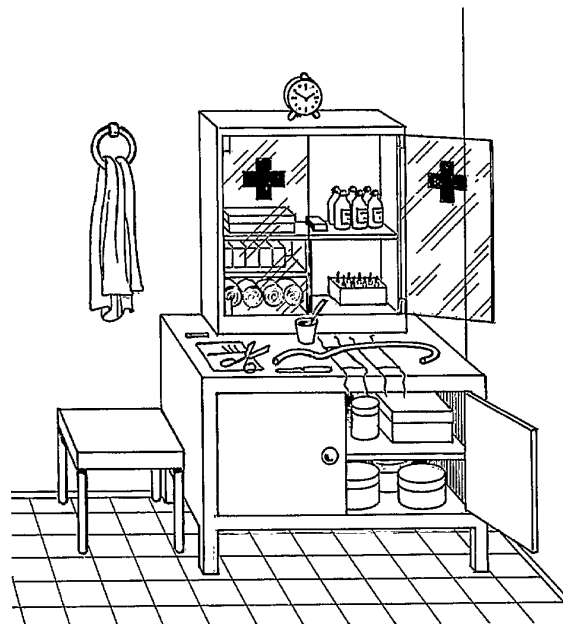

Figure 8: A medical chest

- inform workers about public transport services, schedules, costs and monthly or seasonal ticket offers
- adjust working times to public transport timetables
- introduce flexible working time arrangements to help workers to avoid peak commuting hours
- help organize a shared private transport service
- encourage private transport operators to make reasonable arrangements
- secure adjustments in the public transport services from local authorities.

For workers who want to purchase their own means of transport – such as motorcycles or bicycles – it may be possible to secure cheap bank loans by guaranteeing suitable repayment schemes. A roofed parking place for mopeds and bicycles will ensure a safe, protected area (figure 9).

Recreational facilities

Many workers enjoy practising sports or other recreational activities during their lunch break or after work. Besides being fun, such activities are also likely to increase their physical and mental well-being.

One important impact of recreational facilities is improved social relations within your enterprise. If supervisors or managers participate in recreational activities, this may greatly help in terms of communication and mutual

understanding. The improved morale may also lead to a reduction in absenteeism and staff turnover and facilitate recruitment.

Recreational facilities are often inexpensive. Providing simple sports equipment such as ball, goals, nets, or some board games and magazines is a good starting point.

Singing during breaks is a favourite pastime for some workers. A guitar and other musical instruments would be a good investment. Some workers may even form a singing group which may compete with other enterprises or sing at feasts or festivals and in other social activities organized by your enterprise. Allow workers to organize themselves in selecting their preferred recreational facilities and activities.

Child-care facilities

Many employers find that working mothers are especially committed and efficient workers, but they often need help with the problem of caring for their children.

A clean room, preferably with access to an enclosed space outside, is the main thing you need. A few items of simple furniture and toys help. Access to cooking facilities can solve the feeding problem (figure 10).

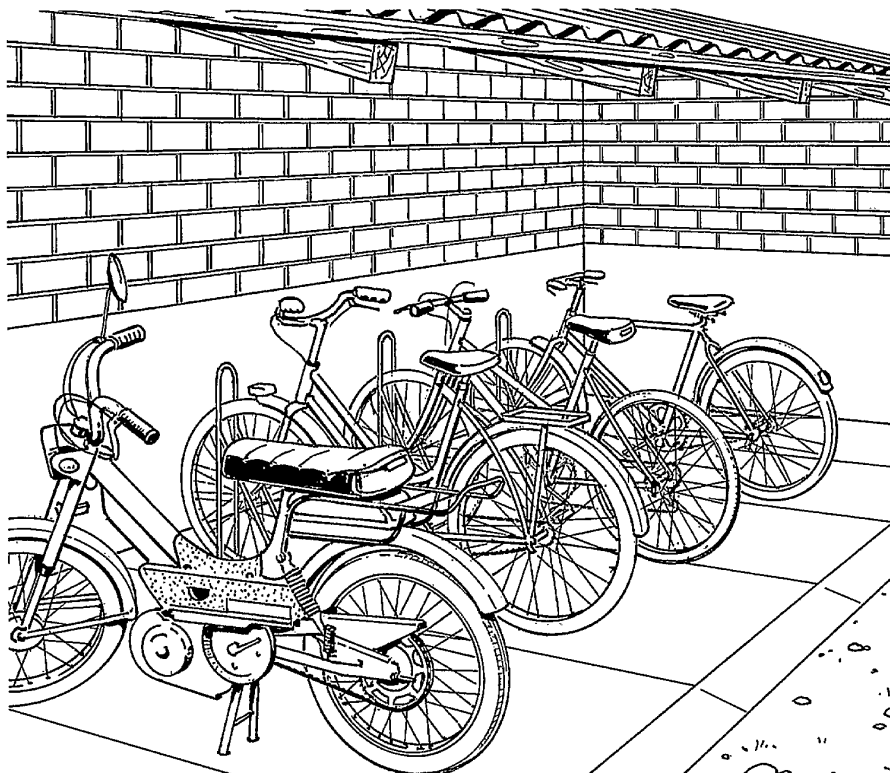

Figure 9: A clean corner protected by a roof can be used as a parking place for mopeds and bicycles

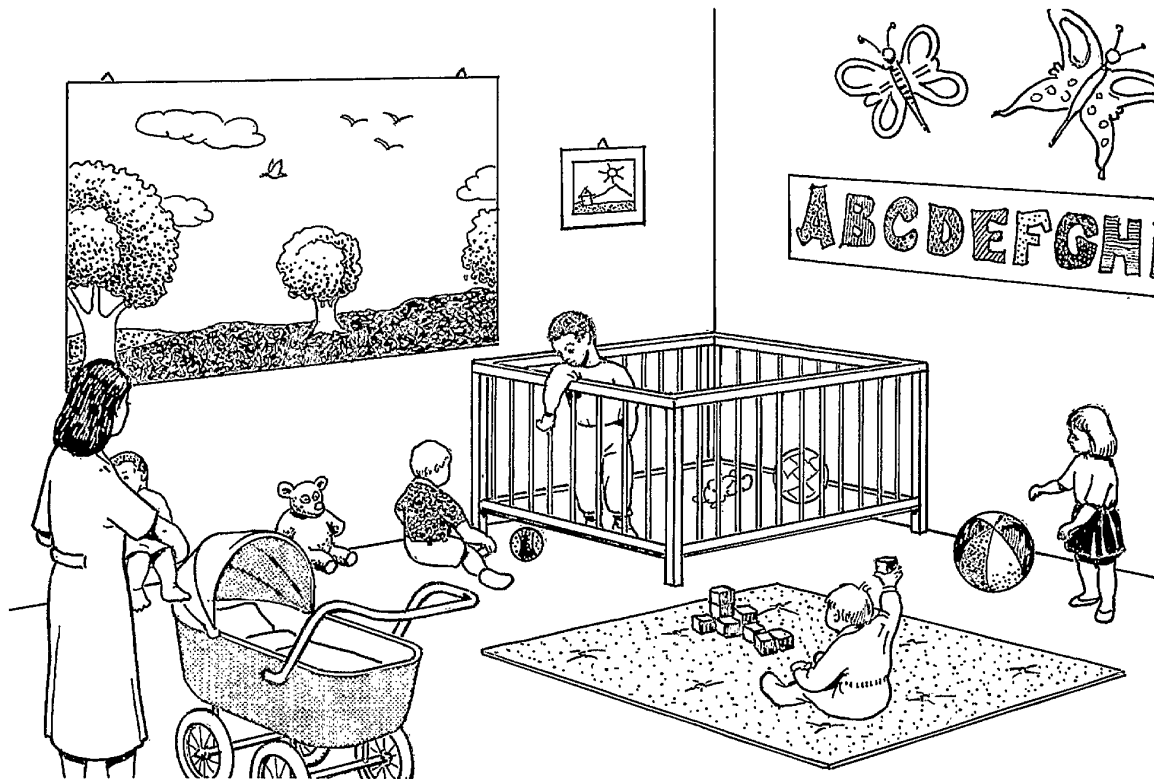

Figure 10: A factory child-care room

Children should never be allowed inside the factory. Sewing, cutting and packing machines, irons and movable carts represent a major hazard for them. Dust or fibres in the air are especially dangerous for the young.

With the help of your workers you may be able to find someone who could care for the children at a low cost. The mothers themselves could take turns. Mothers, especially nursing mothers, should be able to visit their children during breaks. For them, special working time arrangements may be put into practice during these periods.

Birthdays and anniversaries

Many of the former initiatives ensure the daily commitment of your workforce to the enterprise. Another good practice is to allow workers to celebrate their birthdays, etc., perhaps during a lunch break.

You can also celebrate the anniversary of the creation of your enterprise by having a special day once a year for all the workers and their families. It is an excellent opportunity to affirm loyalty to the enterprise. Good food, games, awards and prizes, and a pleasant location help to make such days successful.

Summary

Rules for work-related welfare facilities which contribute to productivity and good labour-management relations

1. Make sure essential facilities serve their purpose:
 - drinking water
 - sanitary facilities.
2. Be ready for emergencies.
3. Make sure that rest means recovery:
 - rest breaks
 - rest areas.
4. Use low-cost facilities to attract and retain the best workers:
 - work clothes
 - lockers and changing rooms
 - eating areas
 - canteens
 - health facilities
 - transport facilities
 - recreational facilities
 - child-care facilities
 - celebrate birthdays and anniversaries.

9

Ensuring sustainable improvements

Small and medium-sized enterprises producing garments must cope with a very tough world and it is rapidly getting tougher. If you want to survive and grow, your enterprise must be dynamic. To compete you need constant improvement; otherwise you will not be able to take advantage of opportunities or resolve problems rapidly.

When you first looked at previous chapters and used the checklists in your factory, you probably found several measures that were worth while. If you attended a workshop organized by a local training institution or you managed to organize a small group of owners and managers to discuss these matters, it is likely that you gathered several good suggestions from them.

Chapters 2 to 8 have given you the information you need to take a fresh, innovative look at your factory. There are a number of ideas which can quickly and easily be applied. We hope you have already benefited from these ideas.

Now it is time to go further. Start with a small, specific area where there are only a few operations that you want to improve. See if you can find ways to make it operate really efficiently. The rest of this chapter will help you to apply the lessons from this action manual as a whole.

You may have read about quality-control circles or other advanced management ideas and wondered if they can be applied in your enterprise. They can. Chapter 10 gives a series of initiatives for involving workers in the process of change and you should select the most appropriate for your needs.

You will have to discard some of your old assumptions and habits and put some real time and work into making your enterprise tough and flexible. If you do so, you will be surprised by the opportunities and energy that will emerge. The following rules will help to introduce change and to monitor it systematically. If, at the same time, you want to start assessing its impact on productivity, have a look at Section 1 in Part 2.

Once you have decided what improvements you want to implement, you may wish to list them; this is the basis of your action plan. If necessary, you can also prepare lists of improvements for each technical theme. You will find a model of a blank and completed form in Section 7 of Part 2.

Develop a complete solution

If you have areas in your workplace which cause problems or bottlenecks, these are probably the result of a combination of factors. For example, suppose you have a problem with the movement of work-in-progress from one operation to another because of improper machine layout and sequence of operation, you will need to improve machine layout and materials handling. In doing so, you also have to consider the positioning of lights and electrical outlets, and the provision of wheeled containers for easy movement. Thus to improve materials handling, you have to consider many factors and evaluate a number of options to minimize impact on the whole production process.

For many improvements you may need to make several changes at the same time in order to meet the objective you have set. Use the whole checklists to look for ways of achieving a complete solution to your problem. Remember that the limit on the productivity of workers comes from several sources, some of which may at first seem unrelated to your objective. Develop a complete solution. Recheck and see if there is something you have left out in each technical area covered in this book:

- materials storage and handling
- workstation design
- productive machine safety, maintenance and environmental control
- lighting
- welfare facilities and benefits
- premises
- work organization.

If the problem is especially complex, establish a group of workers and seek their advice. More information on this is given in Chapter 10.

Make sure your ideas will work

Suppose that one of the changes you have decided on is to improve lighting at a critical workstation. Consider, for example, a worker with a poorly lit workstation, no source of natural light, dark walls and ceiling, and a single light source facing him or her. How would you solve this problem?

Many things can go wrong when you try to improve lighting. For example:

- you could create glare or too much contrast between light and dark areas by installing a more powerful lamp
- you could create heat and glare from an improperly designed and placed skylight
- you could create glare and distraction by placing a worker facing a window
- you could improve the situation by cleaning windows, skylights and lamp fixtures only to have the same problem return in a few weeks because of the lack of regular cleaning
- you could increase the quantity of light when the real problem is the direction of light or the task background.

How could you increase the probability of success? There are several ways to try and be sure that the improvement you have chosen is the best one for your enterprise and that it will work:

- before starting, consider alternative solutions and see which one suits you best
- try your ideas first in a small way and see how they work – for example, before you decide to relocate a whole row of sewing machines in order to take advantage of light from windows, try it first with one machine and evaluate the results
- observe a similar change in the same conditions in another enterprise; it is always better and cheaper to learn from the mistakes of others than from your own
- get the advice of someone who has experience in solving similar problems – this is especially important when your enterprise is trying to solve a problem for the first time.

Mobilize worker support

If you make a worker's job more difficult, the result will be lower productivity and resentment, not higher productivity and appreciation. Your improvements are intended to build loyalty and motivation and to be fully effective you need to be sure that the workers understand how they will benefit. This requires taking a look from the worker's point of view at the impact on job security, pay, level of responsibility, type of supervision, difficulty or ease of work, etc. The workers will certainly be thinking about these things.

Ask yourself who will be affected by the change. This means not only, for example, the worker who uses a new cart but everyone who has been using space in the passageway through which he has to push it. In what way will workers be affected positively? Be sure they know about these positive effects, so that they will appreciate and support your actions. In what way will workers be affected negatively? Could anyone lose their job or have their pay reduced? Workers who expect to be hurt by a

change will often find very good ways of making sure that it does not work very well. You need to do two things: avoid any negative impact on workers; and make sure that they know they have nothing to fear.

The following steps help to make sure that changes are accepted:

- make it known that no one will lose their job, have their pay cut or otherwise be hurt by the change
- explain your plans to the workers and give them a chance to make suggestions
- provide any necessary training. Even where formal training is unnecessary, you may need to relax performance standards during a brief period of adaptation to the new situation
- issue clear instructions and assign specific responsibilities
- show your support for the change by paying close attention to developments, by praising progress and by reacting to any sign of going back to the old methods
- consider incentive pay or other rewards based on performance
- make sure that workers know they should report any problems to you and take action if unforeseen difficulties arise.

One of the best ways to introduce change smoothly and effectively is to assign responsibility for it to a group of workers. If workers are part of the process of planning and implementing the change, they can be confident that their interests will be taken into account. They will be able to suggest their own ideas and they will feel responsible for the success of the improvement. They will therefore not only be cooperative: they will monitor the change carefully and propose or carry out any necessary adjustments.

Remember, changes which are accepted by the workers will be implemented more smoothly. Information about what you are trying to do is very important for the workers' loyalty and motivation. In Chapter 10 you will find a full range of procedures to involve workers in the process of change.

Make improvements which will last

Even simple and immediately productive ideas are not always followed. Old habits are strong, and they do not die easily. There are two basic strategies which help to make sure that improvements are smoothly introduced, effectively implemented and lasting.

- change people's habits and behaviour
- build the change into equipment and facilities.

For most changes you will need to do both to be successful.

If you follow the advice in the previous section on mobilizing worker support, you will do a great deal to make sure that workers are willing to cooperate for change. Reconsider the handling problem discussed in Chapter 2. There are several ways to build the change into the equipment and facilities. The most obvious ones concern designing and constructing some wheeled containers, repairing the floor and clearing the passageways. It may also be necessary to pay attention to storage arrangements or to provide a place for the containers close to the workstation. You may find that two containers are needed. None of these steps, however, will prevent the passageway from getting cluttered and making the new method difficult use. That is why it is suggested that you use special marking tapes or paint stripes on the floor to indicate passageways, storage areas and workstations clearly. It may even be necessary to put up barriers to make sure that the passageways stay clear.

Here are some ways to build changes into equipment and facilities:

- remove any unnecessary tools or equipment which make it possible or easier to return to the old methods
- build the improvement into machines or workstations so that it cannot be removed
- design new or modify existing equipment so that it is easier to use and maintain in the new way
- provide barriers, painted lines, bins, or make other changes which make the improvement easily visible and natural to follow.

The points on management of improvements in the next section will help you to monitor changes in behaviour and to take any necessary corrective action. These steps are very important, but for many types of change they are not enough to guarantee that your objectives will be met.

Manage change

If nothing new ever happened, management would be easy. Instead, change is constant. You have to respond to orders, improve your products, overcome problems with raw materials and equipment, train new workers and, in general, cope with many challenges every day. Some managers run from one problem to another and never develop any real strategy; others are able to go beyond their problems and build real management systems which generate constant improvements in their workplaces.

This book offers you the opportunity of improving your management skills – do not waste this opportunity.

Supervise improvements carefully

Each individual improvement is a challenge to your consistency and determination as a manager. If you pay no attention to what is happening to the improvement,

everyone will gain the impression that it is not important to you.

One way to ensure the completion of an improvement and forget about it is to establish a **firm deadline** and clearly announce it to everyone concerned. It is especially important that the deadline is not a general intention but carries the same kind of commitment you would give to completing a new order on time.

It is also important that you **make someone responsible** for completing the improvement. If no supervisor or worker is appointed, knowing that the improvement is clearly his or her responsibility, then everyone may wait for someone else to do the job. In addition, there will be no one with an incentive to get work started and monitor progress.

Of course, most changes which are worth making will require some workers' time, some materials and perhaps additional purchases. You should **allocate adequate resources** to get the job done.

Once the improvement has started you should request **regular reports on progress** from the person responsible. This will enable you to take corrective action, if necessary, and it will make sure that the improvement is not forgotten.

After the improvement is completed and in operation you should **check the change** to ensure that it works well. It is also important to see that the change is accepted by the workers and that it has no unexpected results.

You should make sure that, throughout the improvement process, you and your supervisors **lead the way** by strictly following the new rules and frequently praising workers involved.

Make improvement a systematic process

Once you have the experience of making a few improvements, you will begin to see the potential for developing a systematic, dynamic approach to the management of change. Each improvement tends to lead to new possibilities. Improvement can become a habit, with everyone trying to find a better way of working. The implications for productivity and motivation are very powerful.

Improvement requires ideas. If you are working with a group of other factory owners and managers, you know how valuable the exchange of ideas and experiences can be. In addition to other entrepreneurs, you can also gain useful information and help from:

- visits to other factories
- productivity and training centres
- employers' organizations, trade associations and chambers of commerce
- specialized government agencies.

All these are useful sources of ideas and technical information. The best source of information, however, is already in your factory. Workers can help you a great deal. Many advanced organizational ideas, such as quality-control circles, are based on using workers as a constant source of ideas for improvement.

Some entrepreneurs do not like to question their workers. They feel that it is a manager's job to decide what to do, and the worker's job to do it. There is much truth in this; the boss must remain the boss. However, you will find that asking the opinion of workers does not reduce your authority or responsibility. Instead, it gives you the information you need to make better decisions. At the same time, it gives workers a feeling that they have something to contribute to the enterprise, which increases their loyalty and motivation.

You will only get ideas from your workers if you make it clear that you want their views and will listen to them. The following steps are effective ways of doing this:

- hold a meeting during normal working time. Explain your goals to the workers (you may find it useful to spell out your goals). Make it clear that they have a stake in your enterprise and that they will benefit if it succeeds. Their jobs and their wages depend on your profits
- make it easy for the workers to give you their suggestions. Set aside a time when you are available. Walk through the workshop and ask questions. Listen carefully to the answers. Do not criticize them. Thank anyone who makes an effort
- above all, **take action** on suggestions in a very obvious way. Even if the first suggestions do not seem very interesting, give them a try. The workers will be watching to see if you sincerely intend to pay attention to their advice.

You can also let a group of workers fill out the checklists, discuss the results and present you their conclusions. None of the ideas on the checklists are dangerous. They have been carefully chosen to save you money and raise your productivity. Why not give your workers a chance to get interested in these goals?

You will find further information on how to obtain help from workers in Chapter 10.

Take action

Now is the time to act. In Section 6 of Part 2 you will find checklist 4 which summarizes this chapter. Take it and a copy of the other checklists onto your shop-floor. Use the action plan model in Section 7 of Part 2 to organize systematic improvements, keep in mind that your workers can help you, and start the process of making your enterprise a better place to work.

Summary

Rules for successful implementation of improvements

1. Develop a complete solution.
2. Make sure your ideas will work.
3. Mobilize worker support.
4. Make improvements which will last.
5. Manage change:
 - supervise improvements carefully
 - make improvement a systematic process
 - take action.

More constructive worker involvement

Is your enterprise in search of higher flexibility to meet the varying demands of the market? Do you want to deliver on time, high quality products and continuously improve your production? Then you need to involve your workers. By giving them the chance to have an active role in increasing the enterprise productivity and improving their own conditions of work, you can release energies and capacities that would otherwise remain untapped.

Likewise, if you have problems with labour turnover or absenteeism, low morale of the workforce or conflicts at the workplace, consider how worker involvement can increase commitment and cooperation in your enterprise and thus contribute to the solution or alleviate these problems.

People, rather than machines, are the key factor of success. This is why in the continuous process of adjustment and change, which is essential for the survival of a competitive enterprise, worker involvement plays an increasingly important role. It may be expressed in a formal way, through bodies or structures which represent the workers, or be of an informal nature, such as direct involvement of individuals in the organizational development of the enterprise, participating in problem-solving, etc. It may include providing information, consultation, negotiation or the creation of joint bodies

based on extended cooperation between management and workforce. The type and degree of worker involvement to be developed in practice will depend on the particular circumstances of each enterprise. It is up to you, together with the workers, to choose the best procedures and practices which meet the special requirements of your working situation.

In this chapter you will find answers to two important questions: why should workers be involved and how should workers be involved? But first, have a look at the basic means of worker involvement immediately available to you, listed at the foot of this page.

Why should workers be involved?

Involving workers in the process of change has several advantages. If workers have a good understanding of working methods or systems, there is likely to be a **greater degree of commitment** and motivation and consequently higher productivity levels.

Let us consider the introduction of new technology in your enterprise. Whether you buy expensive, modern ironing equipment or simple second-hand sewing machines, their use can only be enhanced by the cooperation of informed,

Basic means of worker involvement

- Information** A one-way process. Managers provide information to workers and their representatives through circulars, information meetings or other communication channels.
- Consultation** A two-way process. Managers provide information to workers and their representatives and they, in return, express their opinions and demands. Involvement of this type can take the form of productivity committees, safety committees, technology committees, quality circles, informal or formal discussions with workers and their representatives on specific issues.
- Negotiation** An interactive process. Managers, workers and their representatives discuss and negotiate. This type of involvement includes work councils or negotiating committees leading to the production of formal or informal agreements at enterprise, plant or sector level.
- Cooperation/
Joint bodies** An integrated process. Management and workers work jointly to build up a consensus on issues of common interest. This form of involvement includes special steering committees to facilitate innovation or change, problem-solving teams or working groups.

trained and motivated workers. It would therefore be advisable to involve workers in selecting and installing the new machinery, in assessing the impact on the work environment and in planning and implementing changes needed in the workplace and the production process. Your efforts to involve workers in this way will surely be met with a positive and constructive response. In short, it pays. It will also make the work easier, less dangerous and, generally speaking, more effective, satisfying and humane.

Attempts to improve working conditions will make workers feel that you are concerned for their well-being. It is often surprising how small improvements are appreciated far beyond the time and money invested.

Another good reason for involving workers, particularly in developing and implementing change, is that people are more likely to support an idea which has come from them. Workers may thus become committed to further problem-solving and be prepared to cope with future changes more flexibly. It is therefore important that you make workers aware that they are a key element in workplace changes. However, you should bear in mind that it is not worth involving workers unless you are ready to value their ideas and discuss with them practical ways for the development and implementation of their suggestions for improvement.

A third good reason for involving workers is that *they have valuable information* which can be precious to you. We often forget that they are "experts" in their own workplace and fully acquainted with raw materials, tools, machines and working processes. They can contribute, if given the opportunity, to many areas within the enterprise.

There is still another rationale for worker involvement. Enhanced cooperation when introducing workplace improvements may be a leading factor in *developing labour-management relationships based on mutual respect and trust*. Many employers report improvements in the "working atmosphere" of their enterprise as an intangible, but still very real, benefit brought about by greater worker involvement.

To sum up:

- workers may work more effectively if they are well informed about the reasons for decisions concerning their work environment and the way they work
- workers may become more committed if they see their own ideas put into practice
- workers have many good ideas which can be very useful for your enterprise
- worker participation may foster a more cooperative attitude between management and workers, and also among workers.

How should workers be involved? Ways and means for a successful approach

At this point we assume that you agree about the relevance of involving workers in the process of improving working conditions and in increasing productivity. However, you may well ask yourself: *"I am in favour, but this process is very difficult. How should I start? What is the first step? How should I proceed?"*

It is likely that in your enterprise you are already practising some form of worker involvement. No enterprise can be operational without communication flows between manager and workers and among workers themselves. Circulation of information is part of this communication process. These are basic, although very important, forms of involvement. Probably in your enterprise there are working groups already in operation, for the solution of specific problems or to facilitate production or change. Or, if this is not the case, you perhaps hold working meetings with workers on a periodical or occasional basis to discuss with them issues relevant to the success of your enterprise.

Starting from this reality it is, then, for you to determine where your enterprise is positioned in terms of worker involvement and to identify how this could be further

Advantages in involving workers

Increased

- flexibility in production
- quality of production
- adherence to schedules
- workforce skills and qualification
- workforce self-confidence and esteem
- workforce motivation and commitment
- loyalty to the enterprise
- workers' contribution to changes
- quality of labour-management relations

Decreased

- labour turnover
- absenteeism
- accidents at work
- stress and strain
- conflicts at the workplace

developed in the light of your personal experience, what the workers' acceptance of the idea will be and the real problems you need to solve.

The following rules will help you to start a process of change with the cooperation of the workers. Select the most highly motivated workers. The acceptance of change is a gradual process and further improvements can be introduced to new opportunities and needs.

Provide more information about your enterprise

First, open simple channels of communication with the workers

One first practical step is to give basic information about the enterprise. This openness on enterprise data will certainly contribute to the creation of a more friendly working atmosphere. It will give a positive impression that the enterprise is interested in communicating with its workers. It will also help to confirm, or deny, information that may be circulating unofficially.

Data may include good or bad news and perhaps it may be wise to communicate both. Information could be related to the recognition or claims by clients concerning the quality of the products, new incoming or lost contracts, higher or lower productivity indexes (compared to former periods). Information could also include the announcement of an action plan for improvements in working conditions, including the introduction of new machinery or tools. Depending on the nature of the information, data may be exhibited on notice boards strategically located at the entrance, in rest rooms or in production areas.

If you are already using this technique or want to introduce it, it is important to remember that notice boards require frequent updating. You could enlist the help of some of the workers on this.

To effectively complement this approach, you must be prepared to give supplementary information that may be requested by workers. If appropriate, you may also circulate reports or other documents providing more accurate information on the subject.

Create conditions for participation

Seek and obtain cooperation and agreement for the planned changes

As a second step it is essential that you consult widely with all those who will be affected by the planned changes at the outset.

A good start is to organize a meeting with the workers concerned and explain the changes you intend to introduce and their rationale. During the meeting, it is important to guarantee that no decision will be implemented before completing the "involvement procedure" (you should indicate the steps to be taken) and informing the workers about the final decision. Explain in detail to the workers all secondary changes that may occur due to the primary change. You can invite them, and give them time, to make comments and give advice on such changes.

By activating an open discussion on relevant issues you may obtain good ideas and limit, or avoid, possible worker resistance due to fear of redundancy, reduced wages, more complex work or closer supervision. It may prove advantageous to emphasize that you will make every possible effort to avoid negative effects. It is also important to make clear that you will consult immediately with them in case any unintended effects do occur.

If the workers in your enterprise are organized into trade unions, or if there are other workers' representatives, it is essential to involve them in developing and implementing changes. Their cooperation is an important factor in simplifying and smoothing procedures and achieving mutually agreed solutions. The decision to make their participation formal or informal depends on the nature of local labour-management relations and on legal provisions.

Let workers assess the workplace and express their ideas

Having obtained support from workers and from workers' representatives, provide problem-solving opportunities

An information campaign is a very good way to introduce worker involvement in your enterprise. However, once you have your information system in operation and you have created a basic positive, friendly working atmosphere in your enterprise, you may consider introducing more substantial forms of worker involvement.

How long do you stay in your enterprise each day? Perhaps you are the person who spends the most time there, thus exercising a continuous control over all operations. However, it may be difficult to be personally aware of all aspects of the daily production process. The workers, instead, are fully integrated in their workplace and are therefore in a better position than yourself to perceive small details. You can give these workers an opportunity to assess their workplace. As you know, **checklists** nos. 1 and 2 (see Section 2, Part 2) are useful tools for identifying improvements which can be made at low cost. Obtain spare copies of checklists and distribute them to the workers. Discuss with them how to use them, decide with them which working areas will be evaluated. Ask them to fill in checklists individually. You may be surprised by their level of understanding of the problems.

If they are reluctant to use checklists or to give you a frank evaluation, you may start by inviting them to present their ideas on a relatively easy topic, such as welfare facilities. Put forward, for example, the following question: *"What kind of welfare facilities do you want?"* If their answer is a changing room, then you could ask: *"Where would you locate such a changing room? How would you arrange it at little or no cost?"* Such questions can provide a good breakthrough for getting workers involved.

As the checklist exercise is a sort of suggestion scheme, you could create an opportunity to discuss their responses with them as a group. As always, when you do involve workers, it is important that their advice is taken into full consideration.

Implement a small change

Respond immediately to the workers' ideas

Worker involvement is neither merely asking workers' opinions nor simply giving notice to the workers of your plans for improvement. It is, rather, the creation of a participatory culture and practice in your enterprise.

However, you do not have to start off with a full-scale, major programme of change which may turn out to be impractical. It is wise not to raise expectations which cannot be fulfilled. Instead, you can set up smaller, more achievable targets. Your workers are more likely to comply with a series of limited requests rather than with a single big demand which is difficult to fulfil. When workers are presented with a statement like *"Our enterprise will not be able to survive without a drastic productivity improvement,"* they may be overwhelmed. At the same time such a statement does not propose anything. Perhaps the following statement would be more acceptable to workers: *"In two months we need to be able to increase productivity by two per cent."* Though the goal in both cases is to improve productivity, the first statement conveys a rather negative message; the second, on the contrary, proposes an achievable goal. It is then very important to make this goal operational by indicating small, tangible and controlled steps which workers can easily accomplish. Try to implement any small change that is reasonable and feasible along these lines. In particular, try to put into practice, as soon as you can, some of the ideas proposed by the workers. It is possible that several of them may be implemented immediately.

Achieving small changes is not only easier but also more satisfying and motivating for the workers than having to perform for a long period without any tangible accomplishment. Allowing workers to deal with simple, practical and immediate changes will, if successful, alter their perception of their own capacities and role at the workplace and enable them to solve more complex and difficult problems later on.

Set up a core group of workers

Systematic improvements in your enterprise need an action group

After implementing a series of initial changes proposed by the workers, you may consider setting up a small group of workers, the core group. Discuss this idea with them. You may choose workers from various levels, regardless of their seniority or position. Some enterprises take one worker from each production line to represent that line and rotate them over a period so that all workers are involved in the decision-making process. Better still, let the workers choose their representatives in the core group. The core group should be small, five or six members would be ideal. You may ask them to decide how the group should be named, from where to start, how to obtain the views and attitudes of all those who will be affected by the planned changes, how to develop a systematic change strategy and how to create a positive climate for change.

It is important that you provide appropriate support to the core group, e.g. by allowing its members to organize meetings during working hours, providing it with working facilities, giving them copies of this *Action manual* and making yourself available to answer their enquiries. The group should operate largely in an autonomous way, e.g. timing, agenda and running of the meetings should be, as far as possible, left to the group itself.

It would be wise to inform all workers about the activity of the group, its meetings' schedule and the outcome of its work using your existing information channels.

Above all, both the core group and you should be able to develop a strategy for working conditions and productivity improvements based on further worker involvement.

Involve all workers

Having successfully set up a small, active core group, try to involve all workers

You may argue that worker participation is already practised in your enterprise since you are in contact with the workers on a daily basis. It is, however, rather naive to assume that every worker knows what is happening in the enterprise because it is small. Small enterprises have sound advantages for the successful implementation of changes compared to larger ones. *Firstly*, communication is easier. *Secondly*, it is relatively easy to gain the general cooperation of the workers. *Thirdly*, it is easier to see and assess the results of action taken and improvements made. Take advantage of these favourable conditions by involving all the workers in the process of change.

It is important that an understanding is reached among all parties concerned of the goals to be achieved and the

activities to be undertaken. While at the beginning the initiative may be taken by you alone, and then together with the core group, eventually all workers – whether young or old, male or female, and regardless of their position in the enterprise – should have an opportunity for involvement. The sustainability of changes will depend mainly on each worker's contribution.

You can start by involving workers in a review of their own jobs, individually or in groups, both when changes are planned and when they are implemented. It may also prove useful to give each worker an opportunity to review their working environment or workplace, for him or her to propose further adjustments and to be responsible for the changes.

Once a broad plan on working conditions and productivity improvements is decided upon, more precise proposals explaining the specific actions to be taken should be prepared. The core group may be able to set up a forum to ensure that all workers are kept informed of planned improvements and to receive the workers' views and suggestions. The core group can also play another important role. If there are workers who have particular problems, such as training difficulties or disabilities, the core group can help them to become involved in the planning and implementing of change. Depending on the size of your enterprise you may consider organizing a second core group to deal with other problems.

By now, it should be clear that working conditions and productivity improvements cannot rely only on your personal energy and goodwill. All workers should be actively involved. This will make the improvements work and last.

Provide appropriate training

Attract and retain good workers through appropriate training

It is often said that managers have a better view of matters than their workers because they are more informed, have broader skills and are exposed to a wider range of work environments and situations. If workers are given the necessary information and training, they might be able to reach similar conclusions to the managers, thereby freeing managers' time for strategic aspects of the business.

Providing training should make workers more aware of hazards at the workplace and enhance their capacity to effectively contribute to the reduction or elimination of such hazards. Working conditions and productivity within your enterprise will certainly improve as a consequence of their contribution.

These are good reasons for providing opportunities and resources for workers to be trained. The core group members may need special training to understand and

interpret the information given to them. Training may also be required to improve their communication skills.

It is also important that training be accompanied by opportunities for action: without training and information action is likely to lead to poor results; similarly, training and information without action can lead to frustration.

Trained and capable workers may leave your enterprise after having received costly training and opportunities: some workers look for better jobs or may even wish to set up their own enterprises. On the other hand, having unskilled workers leads nowhere and training can certainly have positive effects in terms of improving both working conditions and productivity. It is said that when something good happens we tell it, on average, to six people. On the contrary, when something bad happens, we tell it to at least twenty people. Training and communication may have a great role in helping you achieve positive results, disseminating those results among workers and managers and increasing the image and profitability of your enterprise.

Enrich workers' jobs

Give workers a meaningful role in the whole production process

Highly fragmented, routine jobs like sewing tasks in assembly line jobs cause fatigue, boredom and stress. This can have a great impact on the efficiency of production operations in your enterprise in terms of absenteeism, low productivity, accidents and quality. People need self-esteem through their work and look for opportunities to be recognized. Workers may be expecting something more from your enterprise than just a wage. They may well wish to participate in decision-making. If this is the case, your enterprise will certainly benefit from their understanding and commitment. Greater tasks, compatible with their skills and experience, are essential for their cooperation.

As explained in Chapter 7 you may consider, for example, introducing job enrichment where work is repetitive and boring by letting workers take care of the maintenance of machines and tools, the handling of materials, stock control, quality control, etc. Eventually, you may agree with workers to add more variety and complexity to their tasks. The core group may also help with this process.

Job enrichment has a number of advantages. The idea is a straightforward one, relatively easy to understand. In almost every work setting, it is possible to assign to workers a combination of a variety of tasks. The evidence suggests that it can quickly produce quantifiable benefits.

Increased motivation and performance depend heavily on the quality of work experience, and not on financial rewards alone. This is a practical way of improving job satisfaction and productivity without additional expense.

Organize workers in teams

Set up semi-autonomous or autonomous groups to improve efficiency and cut supervisory costs. The advantages and ways of introducing autonomous groups were explained in Chapter 7. Please refer to that chapter for the discussion of this rule.

Monitor and review the process

Regard worker involvement as a gradual evolutionary process for a committed organization

It is important to evaluate the effects of worker involvement. To achieve the end goal of having a committed organization, you need to monitor whether expectations are being met or not. It is, however, very difficult to measure the effects of worker involvement and give a straightforward answer to the question *“How much does worker involvement contribute to the profitability of my enterprise?”* Nevertheless, the following questions may help you to assess the impact of such involvement:

- *can information be passed on to workers more accurately and rapidly?*
- *are issues discussed which were previously avoided?*
- *do the workers provide constructive proposals?*

It may be helpful to organize evaluation and review meetings with the core group on a regular basis; you will then be in a better position to make these assessments.

Remember that worker involvement is a gradual, evolutionary process. It needs sustained efforts over a substantial period of time. Established working procedures, habits and attitudes do not change easily. All of us need time to change. You cannot just sit back and wait for the good results to come, but must actively try to involve workers in all phases of production and change. You will need to continuously monitor whether your enterprise is prepared and ready to move on to the next step. However, do not hesitate to go one step back, if necessary.

The pattern of such steps is diverse and difficult to generalize. Nonetheless, it may be useful for you to consider the following possible evolutionary process. Let us start from the situation where there is no worker involvement. In this scenario, the owner-manager plans unilaterally and executes the plans for change himself or herself. A first step towards change is when the owner-manager decides to provide information to the workers. Management may organize, for example, briefing sessions at the workplace and at enterprise level.

The next step occurs when management accepts feed-back from the workers and provides two-way communication. A

“suggestion scheme” for workplace improvement could be introduced at this stage. Sometimes, workers may be rewarded financially for good suggestions. Financial reward is, however, limited in its effect unless it is integrated with other forms of involvement. Recognition and a sense of fulfilment or achievement often supersedes financial reward.

A labour-management consultation committee could be set up at this stage. The committee may deal with several topical issues such as the introduction of new technology, health and safety, changes in work organization or improving quality of products. If the workers are organized into trade unions there would be collective bargaining and negotiation. This is likely to lead to the production of collective agreements. A joint committee may eventually be created by management and workers in search of cooperation and consensus on more strategic issues, such as restructuring your enterprise, investment plans, employment policies, etc.

It is for you to decide how and when to introduce worker involvement in the process of making improvements in working conditions and productivity. The appropriate strategy on how to begin the process depends on your understanding of the long-term advantages of having a committed organization. This chapter offers several options. Select the most appropriate for your enterprise.

Basic steps in worker involvement

1. Decide if you want to have a committed enterprise.
2. Check if you are convinced about worker involvement.
3. Select the right time for beginning.
4. Select the right technique to be applied.
5. Be persistent.

Summary

Rules for successful involvement of workers

1. Provide more information about your enterprise.
2. Create conditions for participation.
3. Let the workers assess the workplace and express their ideas.
4. Implement a small change.
5. Set up a core group of workers.
6. Involve all workers.
7. Provide appropriate training.
8. Enrich workers' jobs.
9. Organize workers in teams.
10. Monitor and review the process.

PART 2

SECTION 1

Useful productivity techniques

As owner/manager of a small enterprise manufacturing garments you want to succeed and grow. You continuously implement improvements in conditions of work and environment listed in your action plan to increase your productivity and profitability. But do you know how much you have improved and what benefits have you gained from the implementation of a particular improvement? Do you know whether you have recovered your costs?

It is very common for managers of small garment enterprises not to have a ready answer when asked how much profit they earned the previous year or for a particular business transaction. If many small and medium enterprises do not have financial data to measure their performance, how many have productivity data?

There are many reasons for the lack of data among small garment enterprises. These include the following: low awareness and appreciation of the importance of data; limited knowledge on what data to collect; lack of people to gather, process and analyse data; and difficult measurement systems.

Productivity measurement indeed is an additional activity but it has numerous benefits. And if the system for gathering data is simple, then little time and effort are required to do the job. In all cases, you need to be systematic and keep records of data useful for different productivity indicators. The sooner you start gathering data, the quicker you will be able to assess your productivity.

Remember – what is important for productivity is to compare data (how was the situation before and how it is now?) and trends (how slow or fast is the situation improving?).

In this section you will **firstly** find sound reasons for paying attention to productivity, a definition of productivity and the different kinds of productivity indexes which are important to assess. **Secondly**, you will find a series of practical examples illustrating how to calculate different productivity indexes. **Thirdly**, practical guidelines for introducing a productivity measurement system and making it sustainable, and practical forms to keep records of data useful for productivity indexes.

1. Benefits of productivity measurement

Productivity measurement enables an enterprise to assess the efficiency of conversion of its resources to goods. Based on this assessment, the enterprise would know whether it is doing well or badly and therefore could take the necessary action to produce more goods for a given amount of resources used. Measurement enables the enterprise to do resource planning and to set quantifiable objectives of productivity levels at which it ought to be operating.

Productivity measurement also enables an enterprise to know whether it is improving its profitability through productivity or through price recovery. Moreover, productivity measurement enables an enterprise to know the results of management decisions, to monitor progress, and to provide feedback. Thus, measurement is integral to the productivity management process.

The WISE¹-Productivity Measurement System (WISE-PMS) has been designed to be simple and easy to understand, use and maintain. The number of productivity measures has been kept to a minimum so as not to burden and confuse users. The productivity measurement indicators selected are those which relate to operations and processes to allow immediate and continuous improvement.

The WISE-PMS aims to provide you with a system which will enable you to measure the impact on productivity of improvements implemented in the different technical areas of WISE, namely: materials storage and handling; workstation and product design; productive machine safety, maintenance and environmental control; lighting; work-related welfare facilities; premises; and work organization. Hence, the WISE-PMS presents measurement indicators that are applicable to these technical areas primarily.

¹WISE stands for Work Improvements for Small Enterprises. It is the acronym of the ILO methodology for improving working conditions and productivity. It belongs to the series *Higher productivity and a better place to work*. See the inner back cover for more details.

2. What is productivity?

Productivity can be defined in many ways but, technically, it is the relationship between output and input:

$$\text{Productivity} = \frac{\text{Output}}{\text{Input}}$$

where **output** refers to the goods produced by an enterprise and **input** refers to the resources used to produce the outputs. Examples of outputs are: pieces of jackets, pieces of shirts, pieces of baby dresses, and others. Examples of inputs are: metres of fabric, kilowatt-hours, worker-hours, machine-hours and others.

The term "productivity" is often confused with the term "production". Many people think that the greater the production, the greater the productivity. This is not necessarily true. We shall show this by an example, but before doing so, let us clarify the meanings of the terms "production" and "productivity".

- **Production** is concerned with the activity of producing goods.
- **Productivity** is concerned with the efficient utilization of resources (inputs) in producing goods (outputs).

In quantitative terms, production is the quantity of outputs produced, while productivity is the ratio of output produced to the input(s) used.

Example: Suppose a subcontractor produces 4,000 pieces of jackets by employing 50 people at 8 hours per day for 25 days. Then in this case,

If production = 4,000 jackets, then

$$\begin{aligned} \text{productivity of labour} &= \frac{4,000 \text{ jackets}}{50 \text{ workers} \times 8 \text{ hrs/day} \times 25 \text{ days}} \\ &= 0.4 \text{ jacket/worker-hours} \end{aligned}$$

Suppose this enterprise increases its production to 4,800 jackets by hiring 10 additional workers at 8 hours/day for 25 days. Then,

If production = 4,800 jackets, then

$$\begin{aligned} \text{productivity of labour} &= \frac{4,800 \text{ jackets}}{60 \text{ workers} \times 8 \text{ hrs/day} \times 25 \text{ days}} \\ &= 0.4 \text{ jacket/worker-hours} \end{aligned}$$

Clearly, the production of jackets has gone up 20 per cent (from 4,000 to 4,800) but the labour productivity has not

gone up at all. Thus, we can see that an increase in production does not necessarily mean an increase in productivity.

Quite often the terms **productivity**, **efficiency** and **effectiveness** are confused with each other.

Efficiency is the ratio of actual output attained to standard output expected.

For example, if the output of an operator is 100 pieces of collars per day while the standard rate is 150 pieces a day, the operator's efficiency is $100/150 = 0.667$ or 66.7 per cent.

Effectiveness, on the other hand, is the degree of accomplishment of objectives.

A person could be effective without being efficient. For example, a project manager may have accomplished the objectives of an assignment very successfully, but if the cost for implementing the project was very high or the project was completed behind schedule, then he or she may have been effective but not efficient.

Some people differentiate **efficiency** and **effectiveness** as follows: efficiency is doing things right and effectiveness is doing the right things.

Productivity is a combination of efficiency and effectiveness. Hence, it is doing the right things right.

3. Basic productivity measurement

While productivity has been defined differently by different people, still the various definitions and interpretations of productivity could be summarized into the relationship between output and input. The two basic and commonly used approaches for measuring productivity are as follows:

Partial productivity is the ratio of output to one class of input. For example, labour productivity (the ratio of output to labour input) is a partial measure. Similarly, material productivity (the ratio of output to material input) and machine productivity (the ratio of output to machine input) are examples of partial productivities.

Total productivity is the ratio of total output to the sum of all input factors. Thus, a total productivity measure reflects the joint impact of all inputs in producing the output. It is a kind of a higher level of productivity assessment combining several or many partial productivity measures.

Studies show that among industrial corporations partial productivity measures are the most commonly used at all organizational levels, particularly in the plant division level.

Partial productivity measures are easy to understand and use. The data needed are both easy to obtain and easy to

compute. Partial productivity is also a good diagnostic tool for pinpointing improvement areas. However, it has some disadvantages. If used alone, it can be misleading and may lead to costly mistakes. Partial measures cannot be used to explain overall cost increases.

Total productivity measure, on the other hand, considers all the quantifiable output and input factors; therefore it is a more accurate representation of the real economic picture of an enterprise. However, total productivity measure does not tell the management of a firm which of its products or services is causing a decline or growth. Nor does it tell them which particular inputs – workers, material, capital, energy, or other expenses – are being utilized inefficiently so that corrective action can be taken. Moreover, data for computation are relatively difficult to obtain unless data collection systems are designed for the purpose.

The WISE-PMS will use both approaches to measure productivity performance. Emphasis will be devoted to partial productivity measures because they are easier to use and understand, require less data and therefore could be used as a tool in taking immediate actions for improvement.

4. How to measure productivity

As explained above, productivity is the relationship between the output of an enterprise and its required inputs. Productivity can be quantified by dividing the outputs by the inputs. Productivity increase could be achieved by improving the output and input ratio; that is, by producing more output, or better output, with a given level of input resources; or by producing the same level and quality of output but reducing the level of required inputs.

While it seems so simple, actual computation is not that easy because application of the formulas is not that straightforward. A number of problems are encountered, among which are:

- difficulty in gathering all the data required
- difficulty in converting all outputs and inputs into a common unit of measure
- difficulty in incorporating all factors affecting the productivity index, such as price fluctuations, quality differences and product mix.

Given these difficulties, some enterprises use **qualitative productivity indicators** to show that productivity is improving in the enterprise. These qualitative productivity indicators are based on judgements, opinions, surveys, feedback and other visible indicators which could be documented in pictures and videos. You may also keep a record of data in a log book. These records would be essential for assessing improvements in the quality performance of your enterprise.

Below you will find several examples of these.

Qualitative productivity indicators

These indicators may provide information on very different issues; the most commonly used are:

- *Higher morale of workers.* This is usually manifested in terms of high level of worker participation in improving activities of the enterprise, enthusiasm, happy faces, high sense of belonging, high level of initiative, high sense of accomplishment, fast pace of work and cooperation.
- *Improvements in the work environment.* Most of these are visible and could be supported, if necessary, with photos or video recordings of a brighter, more spacious, cleaner, and more organized workplace. Several non-standard quantitative productivity indicators are linked to this indicator.
- *Reduced effort in doing work.* Tasks have been organized appropriately to reduce repetition and physical workload. Workers are less fatigued and more productive throughout the day.
- *Improved communication.* There is a policy on information and transparency in the enterprise. Regular information meetings are held. There are fewer grievances and quarrels.
- *Improved labour-management relations.* Workers have easy access to management and vice versa. There is a growing shared trust, concern and cooperation from both labour and management. Labour turnover is reduced.
- *Better customer satisfaction.* The enterprise receives positive feedback and more orders from clients.
- *Improved image and reputation of the enterprise.* Clients, suppliers, visitors and the community as a whole give positive feedback about the enterprise. There are more qualified job applicants.

Non-standard quantitative productivity indicators

Enterprises also use **non-standard productivity indicators**. These are expressed in quantitative terms, but are not calculated as a relationship of output and input. Actually, they are enterprise performance indicators which show how the enterprise is evolving and their impact on productivity and competitiveness.

These indicators provide information on productivity in different aspects of the business: production, work organization, workforce, use of premises, etc. The most commonly used are:

- increase in volume of outputs;
- improved quality of products;
- reduction in volume of rework;
- reduction in volume of rejects;
- reduction in number of late deliveries;
- reduction in number of work-related accidents;
- reduction in absenteeism;
- reduction in number of machine breakdown;
- reduction in machine downtime;
- reduction in overtime;
- reduction in space cost per unit value of product;
- reduction in turnover of employees;
- reduction in sick-leave;
- more customers;
- increased number of improvement suggestions;
- reduction in complaints;
- higher profits.

Sources of information for these indicators vary. You need to decide which you are interested in and start recording data.

Standard productivity indexes

As mentioned before, there are two commonly used approaches for measuring productivity – partial productivity and total productivity. We will now discuss the three ways to compute partial and total productivity indexes. These are the **physical productivity**, the **value productivity** and the **value-added productivity** methods. The main problem here is how to define the outputs, in other words, what are the units of measure for materials, labour, machine, energy, etc. In Section 5 you will find the answer to this.

1. Physical productivity measurement method

This method uses the *quantity* of output and input as data for calculating the indexes. The main physical productivity indexes are:

$$\text{Labour productivity index} = \frac{\text{volume of output}}{\text{labour input}}$$

$$\text{Material productivity index} = \frac{\text{volume of output}}{\text{volume of material inputs}}$$

$$\text{Machine productivity index} = \frac{\text{volume of output}}{\text{machine input}}$$

$$\text{Energy productivity index} = \frac{\text{volume of output}}{\text{volume of energy input}}$$

$$\text{Total physical productivity index} = \frac{\text{Total volume of outputs}}{\text{Total volume of all inputs}}$$

2. Value productivity measurement method

This method uses the *value* of outputs and inputs as data for calculating the indexes. Main value productivity indexes are:

$$\text{Labour productivity index} = \frac{\text{value of output}}{\text{labour inputs (physical or value)}}$$

$$\text{Material productivity index} = \frac{\text{value of output}}{\text{value of material inputs}}$$

$$\text{Capital productivity index} = \frac{\text{value of outputs}}{\text{capital inputs}}$$

$$\text{Machine productivity index} = \frac{\text{value of outputs}}{\text{value of machine input}}$$

$$\text{Energy productivity index} = \frac{\text{value of output}}{\text{value of energy input}}$$

$$\text{Total productivity index} = \frac{\text{total value of outputs}}{\text{total value of all inputs}}$$

3. Value-added productivity measurement method

This method uses *value-added* (expressed in monetary units) as data for calculation, where

$$\begin{aligned} \text{Value-added} &= \text{current income (before tax)} \\ &+ \text{personnel expenses} + \text{financial costs} \\ &+ \text{rent} + \text{tax} + \text{depreciation cost} \end{aligned}$$

Data for value-added computation are taken from the financial statement. In the absence of a financial statement, small garment enterprises could use physical and value productivity measurement methods.

$$\text{Labour productivity index} = \frac{\text{value-added}}{\text{labour input}}$$

$$\text{Capital productivity index} = \frac{\text{value-added}}{\text{capital}}$$

Warning: Note that an index is a ratio between two quantities; therefore it is a number, with no dimension associated to it.

5. How to measure output and input

Outputs are the finished units or the partially produced (work-in-progress) units by an enterprise. They should be tangible or measurable and should meet the quality specifications. As shown in the foregoing examples, outputs are expressed in different units depending on the product, the industry practice or client requirements. Outputs and inputs are expressed either in physical (kilograms, metres, hours, etc.) units or in monetary terms. Ideally, both should be expressed in uniform physical units. Unfortunately, however, this is seldom the case. Thus, monetary values are used but in real terms. A reference period (often referred to as "base period") is normally used for calculations, so that data are in constant values. Deflator or inflator factors may also be used, depending upon whether the cost of outputs and inputs have gone up or down, to eliminate the effect of price variations during the period. Thus, the value of output is expressed as follows:

$$\begin{array}{l} \text{Value of finished units} \\ \text{of a product produced} \\ \text{in any period (base period)} \end{array} = \begin{array}{l} \text{number of finished} \\ \text{units of this product} \\ \text{produced in this period} \end{array} \times \begin{array}{l} \text{selling price per} \\ \text{unit for this product} \\ \text{in the base period} \end{array}$$

whereas the value of work-in-progress units is expressed as follows:

$$\begin{array}{l} \text{Value of partial} \\ \text{units produced} \\ \text{of a product} \\ \text{for this period} \end{array} = \begin{array}{l} \text{number of work-in-} \\ \text{progress units of} \\ \text{this product} \\ \text{produced in this period} \end{array} \times \begin{array}{l} \text{per cent} \\ \text{completion} \end{array} \times \begin{array}{l} \text{selling price} \\ \text{per unit in} \\ \text{the base period} \end{array}$$

As regards input elements, they usually consist of human work input, raw materials, capital, energy and other inputs.

Human work input usually considers the direct labour cost responsible for the production of a particular output. Indirect labour cost could be taken separately, and another productivity index computed separately as well. One could even consider all the human resources employed in producing the output.

Direct labour are those workers involved in processing, assembly and other operations directly linked to production, whereas the indirect labour provides services which indirectly assist production, such as inspection, quality control, storage, transportation, repair and maintenance, shipping, packaging, utilities operations and research.

Labour is usually measured in units such as worker-hours, worker-days, worker-months and worker-years. However, if the unit covering too long a period is used, results are likely to be inaccurate. In principle, it is preferable that labour productivity be measured using worker-hours.

When value of human work input is used, then it is computed by:

$$\begin{array}{l} \text{Value of worker-hours} \\ \text{for the period} \end{array} = \begin{array}{l} \text{number of} \\ \text{worker-hours} \end{array} \times \begin{array}{l} \text{average salary or wage} \\ \text{rate for the period covered.} \end{array}$$

Material input consists of all raw materials expressed in physical (kg, metres, bolts, etc.) or monetary units.

$$\begin{array}{l} \text{Value of raw material} \\ \text{consumed for a product} \\ \text{in a given period} \end{array} = \begin{array}{l} \text{quantity of} \\ \text{material used} \\ \text{for this product} \\ \text{in this period} \end{array} \times \begin{array}{l} \text{purchase price of the} \\ \text{material in the base} \\ \text{period.} \end{array}$$

Capital input. Traditionally, two methods are employed to measure the consumption of fixed capital. One is the depreciation method, wherein depreciation is used as an approximation of the fixed capital consumed. The other is the labour-input equivalent method, where the capital charges are converted into labour-inputs equivalents. The capital input is constituted by the value of the services of capital which is determined by the lease value.

In many cases, machine productivity is used to represent capital productivity because the number of machine-hours is easier to obtain.

Energy input. The energy input is the volume or cost of energy incurred for a given period for a given output. Energy used for different industries vary, but usually these consist of electricity, natural gas and diesel oil. The usual basis for electricity consumption is the periodic electricity bill.

6. WISE-PMS application in the garment industry

Let us apply the above methods and procedures in a medium-sized garment subcontractor enterprise producing jackets. The purpose of this exercise is to show how to calculate, as a matter of example, the following productivities and productivity indexes:

- direct labour productivity
- indirect labour productivity
- total labour productivity
- value direct labour productivity index
- value total labour productivity index
- material productivity
- machine productivity
- energy productivity
- improved productivity of the bundling section due to a better bundling process and transport.

For example, an enterprise with jackets categorized into winter and spring jackets could have five to seven style-orders per year under each category. Each order normally comes in four sizes (small, medium, large and extra large). Each style involves different operations, uses different materials, requires different skills and orders come in different volumes. These factors determine the worker-hours required to finish one jacket. The estimated worker-hours determine the price one could ask for a particular style-order.

Considering the differences for each style, it is not accurate to add all outputs together, even if the enterprise produces only jackets. Each style should be considered as one product and productivity should be measured for each style. A comparative study could be undertaken to find out which style has the highest productivity and which has the lowest. An analysis of the productivity data will identify the factors behind the differences in productivity. This should lead to improvement actions.

Let us suppose that an enterprise has 124 employees, categorized as follows:

Marking and bundling section	10
Preparatory section	30
Sub-assembly section (front)	15
Sub-assembly section (back)	15
Assembly and final operations	25
Finishing section	6
Trimmers	4
Line leaders/supervisors	11
Maintenance	4
Administrative staff	4
	124

The enterprise is quickly gaining new markets and, for a trial period, the sewing sections work in two 12-hour shifts. Given the need to deliver some urgent orders, sewers are requested to work one extra hour. Sewers are paid on a fixed rate based on skills, which is a function of the number of machines each worker could operate and the type of operations handled. The length of service in the enterprise is also considered. Incentives are given to all workers on a pro-rata basis if they exceed the target output for the day.

Data are collected at operator level. Masking tape and a pencil are provided on every work table and each operator records her/his output. Every hour, the line leaders collect the data from the operators, add their respective line outputs and enter the data on the monitoring board. Based on the output data, the line leaders take the necessary action to ensure that targets are achieved. Finished outputs and work-in-progress are recorded by the hour, and a balance shown against the target for the day. The cumulative total of all finished products, work-in-progress of every critical operation and the balance for a certain style-order, are shown on the bulletin board. Everybody knows the work status and whether scheduled delivery date can be achieved.

Productivity indexes can be measured daily, or weekly, or for the whole order. In fact, a running average productivity index could be computed to know whether the productivity performance is within target. Once the data collection system and the measurement system are in place, it is very easy to compute the productivity indexes.

The following data were taken for one sample day:

Output	230 pieces of finished jackets
Sewers present	77 workers
Sewers absent	14 workers
Non-sewers present	30 workers
Non-sewers absent	3 workers
Normal hours of work	12 hours/sewer
Overtime	1 hour/sewer
Actual hours of work	13 hours/sewer

In this enterprise, only sewers are considered direct labour. Non-sewers are considered indirect labour.

Using the **physical productivity measurement method**, we have:

$$\text{Direct labour productivity} = \frac{\text{Volume of output}}{\text{Direct labour input}}$$

$$\text{Direct labour productivity per sewer} = \frac{230 \text{ pieces}}{77 \text{ sewers}}$$

$$= 2.98 \text{ (approx. 3 pieces/sewer)}$$

$$\text{Direct labour productivity per sewer per hour} = \frac{230 \text{ pieces}}{77 \text{ workers} \times 13 \text{ hrs}}$$

$$= 0.23 \text{ jacket/worker-hour}$$

$$\text{This means that: } \frac{77 \times 23}{230} = 4.35 \text{ hours}$$

are needed to finish one jacket of this particular style.

$$\text{Indirect labour productivity} = \frac{\text{Volume of output}}{\text{Indirect labour}}$$

$$= \frac{230 \text{ pieces}}{30 \text{ workers} \times 13 \text{ hrs}}$$

$$= 0.59 \text{ jacket/worker-hour}$$

Management may opt to use the total manpower to calculate labour productivity; then

$$\text{Total labour productivity} = \frac{230 \text{ pieces}}{107 \text{ workers} \times 13 \text{ hrs}}$$

$$= 0.165 \text{ jacket/worker-hour}$$

This means that 6.06 worker-hours are to be paid by the enterprise for every jacket, 4.35 of which is used in the actual sewing and 1.71 worker-hours for support operations.

Is the enterprise doing well or badly? This is the second phase of the productivity management process – the evaluation of productivity data. For this you need to carry out the same exercise in another sample day and compare the new indexes with the above figures.

Let us now use the **value productivity measurement method**. For this you need to know the price of the jacket (say 100 monetary units - MU) and the cost of the average wage paid per hour (say 10 MU).

$$\begin{aligned} \text{Value of direct labour productivity index} &= \frac{\text{Value of output}}{\text{Value of labour input}} \\ &= \frac{30 \text{ pieces} \times \text{MU}100/\text{piece}}{77 \text{ workers} \times 13 \text{ hrs/worker} \times \text{MU}10/\text{hr}} \\ &= 2.29 \text{ MU} \end{aligned}$$

This means that for every monetary unit of direct labour, 2.29 monetary units of revenue is generated.

If we now consider the total manpower instead of direct labour, we have:

$$\begin{aligned} \text{Value of total labour productivity index} &= \frac{230 \text{ pieces} \times \text{MU}100/\text{piece}}{107 \text{ workers} \times 13 \text{ hrs/worker} \times \text{MU}10/\text{hr}} \\ &= 1.653 \text{ MU} \end{aligned}$$

This means that for every monetary unit spent on labour, the enterprise earns 0.653 monetary units, which should cover overhead expenses and profit. In absolute monetary units values, this is 107 workers x 13 hours/worker x 10 MU/hr x 0.653 = MU 9,083 – which represents the daily earnings of the enterprise.

Is this good enough?

In fact, the amount of MU100 a piece does not represent the actual value of the jacket. This represents only the value of labour inputs per jacket based on worker-hour estimate of the owner/manager. All raw material inputs are provided by the contractor. The subcontractor provides labour only. Thus, labour productivity is very important and significant for the enterprise.

Material productivity

Given the situation explained above, the material productivity index is not important to them. However, following a similar procedure as above, you may calculate the material productivity index.

Machine productivity

Machine-hours used are assumed to be equal to worker-hours, thus machine productivity will have the same index as labour productivity.

Energy productivity

Energy productivity is also important for a subcontractor enterprise. The electricity consumption of garment enterprises is relatively high. For this enterprise, electricity daily average cost is, say, 455 monetary units.

$$\begin{aligned} \text{Energy productivity} &= \frac{\text{Volume of output/day}}{\text{Electricity cost in MU/day}} \\ &= \frac{230 \text{ pieces/day}}{\text{MU}455/\text{day}} \\ &= 0.5 \text{ piece/MU} \end{aligned}$$

This means that 2.00 monetary units worth of electricity are used per piece of jacket.

Given that there are 77 sewers in the enterprise, the daily cost of electricity per machine is:

$$\frac{455 \text{ MU}}{77 \text{ machines}} = 5.91 \text{ MU/machine}$$

Value productivity indexes

Using value data:

$$\begin{aligned} \text{Energy productivity index} &= \frac{230 \text{ pieces/day} \times \text{MU}100/\text{piece}}{\text{MU}455/\text{day}} \\ &= 50.55 \end{aligned}$$

This means that for every monetary unit worth of electricity, 50.55 monetary units of revenue are generated.

Productivity increase in the bundling section

Let us suppose we want to measure the productivity of the bundling section of the enterprise, which is a support unit. A bundle may consist of 10 parts or more. Suppose that the workers in that section prepare 400 bundles a day; that will produce 400 jackets.

$$\begin{aligned} \text{Output per day} &= 400 \text{ bundles} \\ \text{Number of workers} &= 5 \\ \text{Number of normal hours of work} &= 8 \text{ hours/worker a day} \end{aligned}$$

$$\begin{aligned} \text{Bundling labour productivity} &= \frac{400 \text{ bundles/day}}{5 \text{ workers} \times 8 \text{ hrs/day}} \\ &= 10 \text{ bundles/worker-hour} \end{aligned}$$

Let us suppose that the production manager, in cooperation with the workers, improved the bundling process on each workstation in the bundling section after attending a WISE comprehensive course by arranging their layout and introducing new carts. Outputs increased to 450 bundles using the same labour inputs, then

$$\begin{aligned} \text{Labour productivity} &= \frac{450 \text{ bundles/day}}{5 \text{ workers} \times 8 \text{ hrs/day}} \\ &= 11.25 \text{ bundles/worker-hour} \end{aligned}$$

Thus, labour productivity increased by 12.5 percent: $(11.25 - 10)/10 \times 100 = 12.5\%$.

Note that in this example production has also increased by 12.5 percent too.

Are there other significant changes as a result of the improvement in the layout and new transportation system? Is there a decrease in errors in bundling? Is there any improvement in the quality of bundling? Are the workers happier? Answers to these may indicate improvement in other productivity factors and data should also be gathered on these topics.

Productivity and welfare facilities

Suppose the enterprise improved its welfare facilities by providing a drinking fountain and rest area and also improved the canteen and toilet facilities. Are there any marked change in workers' attitude towards their work? Do they pay more attention to their work? Is they happier? Is there any reduction in absences? Has labour turnover been reduced? All these changes will bring about productivity improvement – either an increase in outputs or reduction in the amount of inputs used. If there are other improvement measures implemented during the same period, it might be difficult to isolate the impact of improvement in welfare facilities, but studies show that contented and happy workers show their appreciation for management's concern by doing better work.

7. Steps in implementing a productivity measurement system

A step-by-step procedure is essential to achieve successful productivity measurement in your enterprise. If you are considering the implementation of a productivity system,

start gathering data on a limited number of indicators. Once you are confident with them, you can go a step forward. As with the process of change, the key is to be persistent. The following steps could serve as a guide.

1. Select main products

Which are the major products of your enterprise? Select some of them. How do you quantify them? How do you price them? Knowing the performance of these products is important because sometimes they comprise 80 per cent of total production and should therefore be given special attention. To begin, select one or two of the products.

2. Define outputs and inputs

Determine what inputs are used in producing the outputs of the selected products. In what unit of measure could they best be expressed? You should be able to capture all inputs. Sometimes, there is a tendency to disregard small quantities but, when added together, these small quantities become substantial. Some inputs could be very expensive and small quantities may represent a significant amount in monetary units.

3. Identify the critical operations in the production process

The production of the selected products may be jeopardized by some critical operations. Critical operations are those which are difficult to do, costly if errors are committed, require more time, require special skills or machine and are important in the completion of the final product.

4. Decide which productivity factors are significant and useful for implementing continuous productivity improvements

Apart from being interested in keeping track of your main products, or in assessing the impact of changes in some critical operations, you may also be interested in some productivity factors at enterprise level. For garment sub-contractors, labour productivity is very important because labour cost and delivery schedules are greatly affected by labour productivity. If your labour productivity is decreasing, you may decide to train or re-train your workers.

5. Decide on the frequency and level of productivity computations

You may need to record data more or less frequently or at different levels, depending on the information required. Should it be carried out daily, weekly, monthly, per product, per operation, per section, at individual level, or at enterprise level?

6. Select a base period

For long term monitoring of productivity improvements, there is a need to have a base period, i.e. a time period used as a reference for computing productivity values and indexes. Usually, the time when the productivity measurement programme is launched is used as the start of the base period. Other factors such as seasonality of demand patterns, abnormal developments in the enterprise and frequency of productivity measurement may also be considered in the selection of a base period.

7. Design a data collection system, including forms, data sources and data flow

It is very important that the data collection system be simple, easy to understand, use and maintain. Start with the productivity measures which are most relevant or critical for your enterprise.

Data forms should be in the local language for easy comprehension by the workers. Cost of data collection forms could be substantial. Hence, the system should be cost effective.

Accuracy and reliability of the data inputs should be safeguarded, especially during the introduction stage of the system.

Data flow should be simple and straightforward, avoiding unnecessary procedures.

Sample forms are annexed at the end of this section for reference or direct use.

8. Assign and train at least one person (depending on size of enterprise) to handle data processing, evaluation, monitoring, graph preparation and trend analysis

This could be an additional cost, but it is essential for rational management of the business. The use of computers for data processing, storage, easy retrieval and report preparation should be considered. You could also create a core group on working conditions and productivity.

9. Explain to all workers the reasons for productivity measurement

Understanding and appreciation of the importance and use of productivity data will secure the cooperation of everyone. Everybody should understand and agree on the importance and use of data being collected and how to fill up the forms.

10. Give performance feedback using productivity data

The results of your productivity analysis should be disseminated. Everybody should know the results, good or bad. Every worker should be informed how well or badly he/she is performing. Recognition of and rewards for good performance will help in sustaining the measurement efforts of the enterprise. Disincentives for poor performance should be spelt out too.

11. Encourage worker participation in the continuous efforts of the enterprise to improve productivity

After the first steps in introducing the productivity measurement system, it is now time to involve all workers in it. Start with a small group and then move to full cooperation and involvement.

12. Share productivity gains

When you decided to introduce the improvements in conditions of work listed in your action plan, your enterprise benefited with a productivity increase. The ultimate objective of increased productivity is to improve the quality of life for everybody concerned in your enterprise. This can be achieved only if productivity gains are fairly shared with the employees, the shareholders and the consumers. Productivity-based incentive and reward schemes should be developed and implemented as these will reinforce the productivity increases achieved. Now you are in a position to tackle new and more complex improvements in working conditions.

Model forms for the WISE Productivity Measurement System

The WISE-Productivity Measurement System (PMS) currently provides owners/managers of small and medium-sized garment industries with a series of model forms. The purpose of the forms is to help you to introduce a systematic approach for measuring the impact of the working conditions improvements in the performance of your enterprise.

Once you have decided which of the strategic production processes you want to monitor and assess using productivity measures and indexes, you may use the forms to record data.

The WISE-PMS includes the following forms:

- Individual production report
- Group production report
- Attendance personnel record
- Delivery performance record
- Accident record
- Preventive maintenance record
- Customer complaints record
- Energy consumption record
- Employee turnover record

You may wish to adapt these model forms to your particular needs and to develop many others. As soon as you start a systematic process of data recording, you will be able to measure productivity and – what is even more important – productivity changes. Remember that most data can be provided by workers; thus, they are an important source in obtaining reliable data for productivity. Also remember that the more your workers are involved in the process of introducing improvements in conditions of work, the faster you will obtain the data required and the more reliable the data will be to assess productivity.

.

Name of form: Individual production report
Form number: 001
Form to be completed by: Each worker in the sewing area
Form to be submitted to: Line supervisor

Function and description of the form:

This form serves as a tool in monitoring the production output of the workers. Increase in production output, brought about by improvements in working conditions, can be monitored through its use. The form should be completed by each worker at the end of the day. It is then submitted to the line supervisor, who initials it and submits it to the data processor.

Information derived from this form includes the number of defective inputs from the previous operation, the amount of time consumed to produce the output and the machine used to do the operation. This form is also applicable to operations like bundling preparation, sub-assembly, assembly, finishing and revising garments.

The form can be used for a number of days, depending on the entries of the worker.

Identifier/input data description and guide to filling in this form:

Form number

This identifies the type of form. This number is pre-assigned so as to distinguish one form from another. Example: Form number 001 refers to the form that measures the individual production outputs of each worker while number 002 is assigned for group production forms.

Name of operator

This contains the name of the worker.

Processed by

The name of the person assigned to data processing.

Date

(Column 1)

The date the work was done. This should include the day, month and year.

Style and size

(Column 2)

This shows the style and size of the item being produced. With the use of the form, a standard rate of production for a particular style and size will be more or less determined.

Write the style and size of the workpiece being produced. Style and the size coding depends on the standard used. Example: 6754-L (the model's number indicating the style and L for large size).

Operation

(Column 3)

This column records the specific operation being done by the operator.

The operation breakdown varies for each style and may be expressed according to the practice of the enterprise in describing the tasks of the operator. (Example: Attach collar to outer shell, attach zipper.)

Machine number

(Column 4)

This column provides information on the machine or equipment used in the production. This will be helpful in analysing the data collected which can be affected by the machine's reliability and performance.

Using this form would necessitate the enterprise assigning a number for each machine so that tracking is easier. Example: Machine 001 indicates that it is the first machine in the production line. Enhancements can also be made by using letters to identify special machines from the ordinary ones. For instance A-001 to stand for the first special machine and B-001 to stand for the first ordinary machine in the production line.

In cases where the operation does not require a machine, this column can be left blank.

Time start

(Column 5)

This indicates the time when work on a particular style and size commenced. The recording of time under this column should take place at the start of work, after each break or at the beginning of the overtime period. Recording of time must include the exact hour and minute the operation started. Example: 6:57 am.

Time end

(Column 6)

This column indicates the time the operation ended. The recording should take place before each break and the end of the working day or at the end of the overtime period; again, the time the operation was finished must be accurately recorded by stating the hour and the minute. Example: 3:41 pm.

Quantity produced

(Column 7)

This contains the number of outputs finished within a certain time. The number produced can be recorded on another piece of paper (i.e. masking tape) on the working table and the total transferred to the form before going for a break.

In most operations, quantity is expressed in units or pieces. In bundling, output is expressed in bundles. However, it may still be converted to a number of pieces since a bundle contains a fixed number of pieces. Example: 23 pieces (pcs), 45 units.

Defective inputs

(Column 8)

Data for this column will come from the total noted by the worker which is recorded on masking tape. The total of defective inputs will determine the quantity of reworks. In cases where the worker is assembling so many components, a sub-column labelled 'Part' is provided so that workers can specify the defective part and corresponding to that, write the number of defects found.

Record in the column provided the exact number of defective inputs in the process.

Example: Collar 3
Back 1

Worker-hours used

(Column 10)

This part is normally filled in by the data processor, but it is sometimes more convenient for the worker to complete this column. The value to be placed under this column is the time lapsed from the start of the operation to the end.

The total working hours each day is simply the total of the worker's hours recorded for each part of the day.

Worker-hours used = Time lapsed between column 6 and column 5.

Example: Column 6 is 3:45 pm and column 5 is 4:15 pm. Therefore, time lapsed is 30 minutes.

Points to remember:

A careful updating of this form is essential to assess individual productivity. It is useful for assessing newcomers or the impact of training or re-training workers.

Name of form: Group production report
Form number: 002
Form to be completed by: Line leader
Form to be submitted to: Data processor

Function and description of the form:

The group production report will be the reference document in determining the effect of improvement efforts on a particular line.

At the end of each day, the data are totalled. Through this form, the enterprise can assess the effect of the improvement efforts on productivity right where each improvement was implemented.

The form is designed so that it can be used for several days.

Identifier/input data description and guide to filling in the form:

Form number
Form identification number.

Line leader
The name of the line leader assigned for the group.

Date
(Column 1)
The day, month and year when the data were collected.

Style and size
(Column 2)
The style and size of the garment using the coding system of the contractor. Styles are most frequently expressed in numbers, the size in letters. Example: Style 8956 L.

Operation
(Column 3)
Records the task the workers in a group are doing.
Example: Attach collar and upper back, attach lining, etc.

Machine number(s)
(Column 4)
Indicates all the machines used by a group of workers.
Example: 001, 004, 006.

Total quantity produced
(Column 5)
Shows the quantities produced by a group of workers classified according to the style, size and operation being done.

Quantity reworked
(Column 6)

The reference documents required for filling up this column are those Forms 001 (individual production reports) representing the complete sequence of sewing or assembling operations carried out in each production line or working group. Through them, the data processor would be able to list which are the most common errors and identify the operations causing problems in the line or the group.

Worker-hours used
(Column 7)

Refer to Form 001, column 10. The worker-hours for the same style and size undergoing the same operation must be added and recorded corresponding to their classification and must be placed under column 7 of Form 002.

Labour productivity
(Column 8)

Labour productivity is the ratio of the output of the workers to the worker-hours utilized. The figures for this column should be computed by the data processor at the end of the day.

Computation of labour productivity:

$$\text{Labour productivity (column 8)} = \frac{\text{Total quantity produced (column 5)}}{\text{Worker-hours used (column 7)}}$$

Points to remember:

A careful updating of this form is essential for assessing labour productivity of production lines or team work.

Name of form: Attendance personnel record
Form number: 003
Form to be completed by: Administrative personnel

Function and description of the form:

This form is designed to collect data on the level of attendance of workers. Since improvements will be implemented in the workplace, attendance is seen as one of the indicators on the response of the workers to the changes in the work environment, thus providing useful feedback.

The administrative person assigned to regularly updating the data must initial the bottom of the day's entry.

Identifier/input data description and guide to filling in the form:

Form number
Form identification number

Month
This indicates the period inputs were collected. Example: August.

Time card number
(Column 1)
To put order into the data collection, it is better to arrange the name of workers alphabetically and their personal time-card number recorded by their name.

Name of employee
(Column 2)
Write the name of the employees in alphabetical order, one on each line.

Days
(Column 3)
Sub-columns numbered 1 to 31, represent the maximum total number of days in a month. Enter a P (present) if the worker is at work; enter an A (absent) if not. From this, the administrative personnel assigned to update this form can monitor the daily absences of workers. If the worker has been marked absent for the day but has reported sick for that day, an SL mark should be indicated on the corresponding date. Vacation leave should to be recorded as VL on the corresponding day.

Total sick leave
(Column 4)
Total sick leave per worker can be determined by counting the SL marks for the whole month (count from left to right). Total sick leave at the enterprise level can be determined by adding up all entries under column 4 (count from top to bottom).

Total vacation leave
(Column 5)

This is the total number of vacation days incurred for the whole month. Total number of vacation days per employee can be determined by adding all VLs from left to right. At enterprise level, total VL is the summation of all entries under column 5 (counting from top to bottom).

Total absences
(Column 6)

Input to this column can be determined in the same manner as column 4. At enterprise level, total absences is the summation of all entries under column 5.

Points to remember:

A careful updating of this form is essential in assessing labour productivity.

Name of form: Delivery performance record
Form number: 004
Form to be completed by: Administrative personnel

Function and description of the form:

This form is designed to assess the performance of the enterprise in meeting its delivery schedule. Once a change, which is expected to improve the delivery performance, has been implemented, this form can be used to monitor the effects of such a change.

Identifier/input data description and guide to filling in the form:

Date

(Column 1)

Indicate the specific day, month and year when data were collected.

Purchase order number

(Column 2)

The reference number of the purchase order from the contractor.

Scheduled delivery date

(Column 3)

The delivery date required by the contractor.

Actual delivery date

(Column 4)

Record the date of actual delivery.

Delayed delivery

(Column 5)

This is the difference between the scheduled delivery date and the actual delivery date which should be computed by the data processor.

Reason for delay

(Column 6)

Record the main reasons for the delay.

Points to remember:

Data of this form is useful in studying the trend in delivery delays and this information should be passed on to the workers.

Name of form: Accident record
Form number: 005
Form to be completed by: Administrative personnel

Function and description of the form:

The accident record is updated if an accident occurs. Based on the testimony of the worker(s) and supervisor concerned, the administrative personnel update the report and prepare a monthly summary to assess the trend. The information in this form enables the frequency of accidents in the workplace to be assessed as well as the most common injury and cause.

Identifier/input data description and guide to filling in the form:

Date

(Column 1)

Write the specific day, month and year the accident occurred.

Injury

(Column 3)

Take note of the injury caused to the worker by the accident. Example: hand pinched by machine needle, fracture of foot, etc.

Cause

(Column 4)

Record the environmental factors that resulted in the injury. Example: machine control not functioning well, box of materials fell.

Remarks

(Column 5)

State the action undertaken. Example: First aid given – returned to work or referred to hospital.

Points to remember:

The information recorded in this form is useful for possible improvements in working conditions. Data on the number of days with no accidents may be shown in strategic places. A similar form to register accidents (with injury) might also be useful.

Name of form: Preventive maintenance record
Form number: 006
Form to be completed by: Maintenance personnel

Function and description of the form:

This form captures the data that would show any improvement in machine or equipment performance after a preventive maintenance policy and procedure had been implemented.

Identifier/input data description and guide to filling in the form:

Period

Indicate the period covered by the form.

Machine number

(Column 2)

Indicate the number of the machine or piece of equipment where failure occurred. Example: Machine number 001.

Time breakdown reported

(Column 3)

Record the time the breakdown was reported for repair.

Time maintenance work started

(Column 4)

Record the time the repair began.

Time machine resumed operation

(Column 5)

Record the time the machine or equipment resumed operation after a test run.

Machine downtime

(Column 6)

Record the amount of time the machine was out of action
(Column 5 minus Column 3)

Cause of breakdown

(Column 7)

State the cause of breakdown and the part where failure originated. Example: Part needs replacement; screws missing.

Points to remember:

Apart from maintenance personnel, the preventive maintenance policy should also include sewers and other workers. Procedures or checklists for preventive maintenance tasks should be distributed to workers and training for such tasks should be part of the preventive maintenance policy.

Name of form: Customer complaints record
Form number: 007
Form to be completed by: Administrative personnel

Function and description of the form:

This form is designed to monitor feedback from the customer and to enable immediate action on the complaints received. It helps to monitor the handling of the complaint and to check if and how the problem was resolved. It requires that the person with responsibility for completing the form has to record the action taken to rectify the problem.

Identifier/input data description and guide to filling in the form:

Period

Record the period covered by the form.

Customer

(Column 1)

The name of the customer who raised a complaint on the product manufactured or service being offered by the enterprise.

Complaint and date

(Column 2)

State the nature of the complaint. Refer the complaint to the person assigned to resolve such a problem.

Action

(Column 3)

Write down any action taken to address the problem.

Action taken by

(Column 4)

Indicate the name of the person responsible for resolving the problem.

Remarks

(Column 5)

Indicate whether the problem has been resolved or not and the date.

Points to remember:

If you work with homeworkers, you may adapt this form to keep a record of the problems raised and solutions adopted to improve working methods for them.

Name of form: Energy consumption record
Form number: 008
Form to be completed by: Administrative personnel

Function and description of the form:

Recording the consumption of electricity is a tool to monitor the variations in energy consumption after an improvement to save energy (e.g. in lighting, etc.) has been introduced.

Identifier/input data description and guide to filling in the form:

Period

Record the period covered by the form.

Date

(Column 1)

Write down the date.

Kilowatts used

(Column 2)

Record consumption of electricity as shown on the electricity bills for that particular period.

Rate per kW

(Column 3)

State the rate per kilowatt-hour including additional charges.

Sewing worker-hours

(Column 4)

From Form 002, determine the sewing worker-hours for the period covered.

Points to remember:

If two or more improvements for saving energy were made in the relevant period, care should be taken in attributing the savings to each of them. Note that changes in kilowatt consumption could be altered by electricity cuts and variations in other production processes (i.e., ironing, hot stamping, etc.). Installation of power-factor correction equipment should be considered.

Name of form: Employee turnover record
Form number: 009
Form to be completed by: Administrative personnel

Function and description of the form:

The employee turnover will give an indication on the satisfaction of the employees on the working environment and organizational system of the enterprise.

Identifier/input data description and guide to filling in the form:

Name of employee

(Column 1)

Record all the employees of the enterprise.

Date hired

(Column 2)

Indicate the month and year each employee was hired.

Date disassociated with the enterprise

(Column 3)

Indicate the month and year the employee resigned or was terminated from the enterprise.

Reason

(Column 4)

State the reason the employee resigned or was terminated.

Points to remember:

Based on this record you can prepare a graph, perhaps once a year, showing the variations of employee turnover. Variations may be linked to the introduction of changes in conditions of work.

SECTION 2

Three effective checklists for action

The three checklists included in this section are powerful tools for identifying improvements which can be made in your garment enterprise. The items they contain are ideas for action, not simply areas to check for possible problems. Most are simple and can easily be applied. More information on each technical theme covered in the checklists can found in Chapters 2 to 8.

There are three checklists in this section:

- Checklist No. 1 deals with low-cost improvements in general working conditions. We suggest you begin the process of change with this checklist. This will enable you to have a quick but precise idea of the problems you are confronting and the solutions available. If you are attending a training seminar, it is recommended that this checklist be used during the first training session. The content of this checklist corresponds to Chapters 2 – 8 of this manual.
- Checklist No. 2 focuses attention on sewing workstations and the sewing process. Use this if working processes pose problems in your enterprise. However, we suggest you check the other technical issues covered in checklist No. 1 as most production problems are interrelated. The content of this checklist corresponds mainly to Chapter 3 (Practical workstation and product design) of this manual.

- Checklist No. 3 will help you specifically in planning, launching and monitoring the process of change with the cooperation of the workers. If you are attending a course, we suggest you use this checklist immediately after the middle-course session, which is the time to start organizing the implementation of improvements. In line with this checklist, we suggest you pay attention to Chapter 9 (Ensuring sustainable improvements), Chapter 10 (More constructive worker involvement), and to Section 1 of Part 2 (Useful productivity techniques) of this manual.

All checklists should be filled out individually. It helps if several people fill out the checklists separately and then discuss their responses as a group. If you are taking a course, these group discussions will be part of the programme. If you have organized your own small group, make photocopies of the checklists and give them to each member. If you are working alone, consider asking supervisors or some workers to fill out the checklists and discuss the ideas for action with you. Checklists are an effective suggestion scheme.

Once the checklists No. 1 and 2 have helped you identify improvements in your workplace, use the rest of this book to learn how to design and introduce them. Chapters 2 – 8 follow the same order as the checklists.

The three checklists form the basis for preparing your action plan for change.

1. Improving general workplace conditions

How to use the checklist:

- A. If you are not reviewing your own enterprise, you will need some general information. Ask the owner or manager any questions you may have. You should learn about the main products and production methods, the number of workers (male and female), the hours of work (including lunch-breaks, other breaks and overtime) and any important operational or labour problems.
- B. Define the work area to be checked. In the case of a small garment enterprise the whole production area should be checked. In the case of a larger enterprise, particular work areas can be defined for separate checking.
- C. Read through the checklist and spend a few minutes walking around the work area before starting to check.
- D. Read each item carefully. Look for a way to apply the proposed action. If necessary, ask the owner or workers questions. Before approaching workers, obtain the permission of the owner. If the measure has already been applied or it is not needed, mark "No" under "Do you propose action?" If you think the measure would be worthwhile, mark "Yes". Use the space under "Remarks" to put a description of your suggestion or its location.
- E. After you have finished, look again at the items where you have marked "Yes". Choose a few where the benefits seem to be most important. Mark "Priority" for these items.
- F. Before finishing, make sure that for each item you have marked "No" or "Yes", and that you have marked "Priority" where appropriate.

Materials storage and handling

- 1. Clear work tables and benches of unnecessary items for efficient movement and visibility of materials.

Do you propose action?

No Yes Priority

Remarks:

.....
.....

- 2. Remove unnecessary items under the stairs, in aisles, in passageways, on walls, in corners, in open areas and around fire extinguishers.

Do you propose action?

No Yes Priority

Remarks:

.....
.....

- 3. Provide multi-level storage racks and containers and properly label these for easy stocking, inventory and withdrawal of cloth materials and supplies.

Do you propose action?

No Yes Priority

Remarks:

.....
.....

- 4. Provide containers to hold input materials and collect outputs for every operation.

Do you propose action?

No Yes Priority

Remarks:

.....
.....

- 5. Use push-carts, mobile racks, gravity chutes and other devices with rollers to move heavy or bulky materials.

Do you propose action?

No Yes Priority

Remarks:

.....
.....

6. Install devices like long tables to connect line operations so workers could just push their outputs to the next operation eliminating input and output containers.

Do you propose action?

No Yes Priority

Remarks:

.....
.....

7. Paint line marks on floors to distinguish the aisles and remove obstructions in these areas for faster movement of materials and workers.

Do you propose action?

No Yes Priority

Remarks:

.....
.....

8. Level floor surface and use ramps for easy movement of materials handling equipment and to prevent accidents.

Do you propose action?

No Yes Priority

Remarks:

.....
.....

Workstation design

9. Put materials, tools, switches, and other machine and equipment controls within easy reach of workers.

Do you propose action?

No Yes Priority

Remarks:

.....
.....

10. Provide suitable tables with stable and smooth work surface for marking, bundling, cutting, inspection, ironing and trimming tasks.

Do you propose action?

No Yes Priority

Remarks:

.....
.....

11. Provide sewers with seats and footrests comfortable enough for sitting all day.

Do you propose action?

No Yes Priority

Remarks:

.....
.....

12. Provide non-sewers with benches of appropriate height or prop stools.

Do you propose action?

No Yes Priority

Remarks:

.....
.....

13. Provide inspection, bundling, and marking tables with appropriate footrests.

Do you propose action?

No Yes Priority

Remarks:

.....
.....

14. Provide labelled boxes for needles, ribbons, buttons, hooks, threads and other small tools and materials.

Do you propose action?

No Yes Priority

Remarks:

.....
.....

15. Provide each sewing machine and working table with a rubbish bag.

Do you propose action?

No Yes Priority

Remarks:

.....
.....

16. Design garments for easy assembly, low waste and high quality.

Do you propose action?

No Yes Priority

Remarks:

.....
.....

17. Use jigs, fixtures, feeders and other devices to save time and effort.

Do you propose action?

No Yes Priority

Remarks:

.....
.....

Productive machine safety, maintenance and environmental control

18. Attach and maintain proper guards to power transmission belts, presser feet, blades of cutting machines, hot irons and sealing equipment, steam generators, and to other hazardous machines.

Do you propose action?

No Yes Priority

Remarks:

.....
.....

19. Provide sewing machines, irons and other electric equipment with visual displays (i.e. red warning sign) and an emergency button.

Do you propose action?

No Yes Priority

Remarks:

.....
.....

20. Train workers to do routine maintenance tasks on their machines and keep a record for each.

Do you propose action?

No Yes Priority

Remarks:

.....
.....

21. Place a warning sign on out-of-order machines and equipment.

Do you propose action?

No Yes Priority

Remarks:

.....
.....

22. Substitute organic solvents for cleaning or dyeing, and solvent-based markers with substances which dissolve in water or less hazardous organic solvents.

Do you propose action?

No Yes Priority

Remarks:

.....
.....

23. Store all organic solvents for cleaning, dyeing, etc. in containers with a lid and in an area where contamination and fire are unlikely to happen.

Do you propose action?

No Yes Priority

Remarks:

.....
.....

24. Properly label containers of hazardous substances. (i.e. with contents, possible hazard and caution for handling)

Do you propose action?

No Yes Priority

Remarks:

.....
.....

25. Use a form to record accidents and work-related incidents.

Do you propose action?

No Yes Priority

Remarks:

.....
.....

26. Introduce or improve general ventilation: if necessary, consider using extractor fans.

Do you propose action?

No Yes Priority

Remarks:

.....
.....

27. Establish a regular cleaning plan to remove dust and cobwebs from floors, ceilings and walls.

Do you propose action?

No Yes Priority

Remarks:

.....
.....

Lighting

28. Add skylights and/or windows and keep them clean for more effective use of daylight.

Do you propose action?

No Yes Priority

Remarks:

.....
.....

29. Reposition existing lights, install reflectors, paint ceilings and walls in paler colours or add light sources to improve general lighting.

Do you propose action?

No Yes Priority

Remarks:

.....
.....

30. Provide local lighting or adjustable lamps with a switch for sewing, marking, cutting and inspecting tasks and provide workers with vision problems with special lamps.

Do you propose action?

No Yes Priority

Remarks:

.....
.....

31. Provide separate switches for lights.

Do you propose action?

No Yes Priority

Remarks:

.....
.....

32. Clean lamps and fixtures regularly to get higher lighting levels.

Do you propose action?

No Yes Priority

Remarks:

.....
.....

33. Provide light shields or reposition glaring light sources for more comfortable and productive visual tasks.

Do you propose action?

No Yes Priority

Remarks:

.....
.....

34. Arrange lights in sewing areas so that shadows on workpieces are prevented and proper illumination is provided.

Do you propose action?

No Yes Priority

Remarks:

.....
.....

Welfare facilities

35. Provide an adequate supply of cool, safe drinking water near the workplace.

Do you propose action?

No Yes Priority

Remarks:

.....
.....

36. Provide a separate, comfortable, and hygienic place for meals – not the workplace – and equip it with cooking facilities.

Do you propose action?

No Yes Priority

Remarks:

.....
.....

37. Provide the required number of regularly cleaned toilets for women and men separately and close to the main working sections.

Do you propose action?

No Yes Priority

Remarks:

.....
.....

38. Provide lockers for workers' personal belongings separately for women and men.

Do you propose action?

No Yes Priority

Remarks:

.....
.....

39. Provide eating areas, rest areas or recreation areas for workers to eat, rest or relax during breaks.

Do you propose action?

No Yes Priority

Remarks:

.....
.....

40. Install and maintain a first-aid box with instructions for emergencies.

Do you propose action?

No Yes Priority

Remarks:

.....
.....

41. Train some workers in first aid and make special arrangement with a nearby hospital or clinic for emergencies.

Do you propose action?

No Yes Priority

Remarks:

.....
.....

42. Make arrangements for child-care facilities for workers' children and appoint a person to look after this arrangement.

Do you propose action?

No Yes Priority

Remarks:

.....
.....

43. Provide recreational facilities near the rest-room or the workplace.

Do you propose action?

No Yes Priority

Remarks:

.....
.....

Premises

44. Improve the insulation of the building by lining metal walls and roofs with suitable insulating materials or by installing ceilings.

Do you propose action?

No Yes Priority

Remarks:

.....
.....

45. Install an effective heating system and ensure hot air is not lost through windows or other openings.

Do you propose action?

No Yes Priority

Remarks:

.....
.....

46. Provide enough fire extinguishers within easy reach and remove all obstructions around them.

Do you propose action?

No Yes Priority

Remarks:

.....
.....

50. Provide adequate number of electrical outlets close to each workstation.

Do you propose action?

No Yes Priority

Remarks:

.....
.....

47. Provide at least two unobstructed ways out of every floor or every big room to facilitate in-and-out traffic and exit in case of emergencies.

Do you propose action?

No Yes Priority

Remarks:

.....
.....

51. Designate a smoking area and provide adequate ashtrays. Introduce a "no smoking" policy in working areas.

Do you propose action?

No Yes Priority

Remarks:

.....
.....

48. Mark entrance, aisles and exits, and keep them clear from obstruction.

Do you propose action?

No Yes Priority

Remarks:

.....
.....

52. Provide adequate number of rubbish bags.

Do you propose action?

No Yes Priority

Remarks:

.....
.....

49. Eliminate frayed, irregular or entangled wiring connections, and schedule regular check-ups by an electrician.

Do you propose action?

No Yes Priority

Remarks:

.....
.....

53. Arrange and keep office tables, chairs and cabinets clean and well maintained.

Do you propose action?

No Yes Priority

Remarks:

.....
.....

54. Clean external areas, gardens and the whole workplace to make the workplace pleasant and bright.

Do you propose action?

No Yes Priority

Remarks:

.....
.....

58. Secure sufficient rest periods by avoiding long working hours and minimizing night shifts.

Do you propose action?

No Yes Priority

Remarks:

.....
.....

55. Update bulletin boards and use them to communicate useful information to workers.

Do you propose action?

No Yes Priority

Remarks:

.....
.....

59. Use buffer stocks at sewing sections, etc. to keep work-flow constant while allowing self-paced work.

Do you propose action?

No Yes Priority

Remarks:

.....
.....

Work organization

56. Reduce the number of tasks by determining operations that can be combined, rearranged, simplified or eliminated.

Do you propose action?

No Yes Priority

Remarks:

.....
.....

60. Provide music to help keep workers alert and prevent boredom.

Do you propose action?

No Yes Priority

Remarks:

.....
.....

57. Help keep workers alert and reduce fatigue through frequent changes in tasks, opportunities to change posture and short breaks.

Do you propose action?

No Yes Priority

Remarks:

.....
.....

61. Provide training and retraining to ensure responsible, flexible jobs.

Do you propose action?

No Yes Priority

Remarks:

.....
.....

62. Make production lines more efficient by analysing operations and balancing the lines.

Do you propose action?

No Yes Priority

Remarks:

.....
.....

65. Introduce a production progress control system to ensure orders are completed on time.

Do you propose action?

No Yes Priority

Remarks:

.....
.....

63. Arrange layout and the order of operations to minimize work-flow and materials handling.

Do you propose action?

No Yes Priority

Remarks:

.....
.....

66. Introduce group activity for workers to improve working conditions, quality and productivity and reduce supervisory cost.

Do you propose action?

No Yes Priority

Remarks:

.....
.....

64. Introduce flexible working-time arrangements and part-time work to facilitate workers' family responsibilities.

Do you propose action?

No Yes Priority

Remarks:

.....
.....

2. Organizing better sewing workstations

How to use the checklist:

A. If you are not reviewing your own enterprise, you will need some general information on the sewing room. Ask the owner or manager any questions you may have. You should learn about the main products and production methods, the number of workers (male and female), the hours of work (including lunch-break, other breaks and overtime) and any important operational or labour problems.

B. Read through the checklist and spend a few minutes walking around the sewing room before starting to check.

C. Read each item carefully. Look for a way to apply the proposed action. If necessary, ask the owner or workers questions. Before approaching workers, obtain the permission of the owner. If the measure has already been applied or it is not needed, mark "No" under 'Do you propose action?' If you think the measure would be worthwhile, mark "Yes". Use the space under "Remarks" to put a description of your suggestion or its location.

D. After you have finished, look again at the items where you have marked "Yes". Choose a few where the benefits seem to be most important. Mark "Priority" for these items.

E. Before finishing, make sure that for each item you have marked "No" or "Yes", and that you have marked "Priority" where appropriate.

1. Ensure machines are not operating slowly because of wear and tear.

Do you propose action?

No Yes Priority

Remarks:

.....
.....

2. Maintain machines properly.

Do you propose action?

No Yes Priority

Remarks:

.....
.....

3. Provide adequate visual displays to sewing machines with which workers can recognize if the machine is switched on or not.

Do you propose action?

No Yes Priority

Remarks:

.....
.....

4. Provide samples or models of output in each sewing workstation to ensure stable production quality.

Do you propose action?

No Yes Priority

Remarks:

.....
.....

5. Provide a stable sewing table wide enough or use a stable side-table with wheels, small mobile multi-level racks etc., to ensure a wide work-surface.

Do you propose action?

No Yes Priority

Remarks:

.....
.....

6. Cover the worker-side edge of work tables with cloth or similar soft material or round the edge for more comfortable arm support.

Do you propose action?

No Yes Priority

Remarks:

.....
.....

7. Provide good quality, adequate-size tools, e.g. small scissors for cutting threads, or scissors or cutters for cloth materials.

Do you propose action?

No Yes Priority

Remarks:

.....
.....

8. Put needles, scissors, small raw materials in small boxes with a front opening separately, and place them within easy reach.

Do you propose action?

No Yes Priority

Remarks:

.....
.....

9. Install feeding devices in selected sewing workstations.

Do you propose action?

No Yes Priority

Remarks:

.....
.....

10. Use gravity or provide chutes to guide output.

Do you propose action?

No Yes Priority

Remarks:

.....
.....

11. Provide sewers with seats (with backrests) and footrests comfortable enough for whole day sitting.

Do you propose action?

No Yes Priority

Remarks:

.....
.....

12. Provide each sewing machine and work table with litter bag to contain thread trimmings and other waste.

Do you propose action?

No Yes Priority

Remarks:

.....
.....

13. Provide an adequate number of electric outlets, and, if possible, place the outlets above sewing workstations.

Do you propose action?

No Yes Priority

Remarks:

.....
.....

14. Provide local light sources to avoid sharp shadows at the sewing spot.

Do you propose action?

No Yes Priority

Remarks:

.....
.....

15. Eliminate direct or indirect glare sources for good visual performance.

Do you propose action?

No Yes Priority

Remarks:

.....
.....

16. Place warning signs on out-of-order sewing machines.

Do you propose action?

No Yes Priority

Remarks:

.....
.....

17. Consider a round-table or U-type group workstation instead of line work arrangement to avoid monotonous work or for better use of work area.

Do you propose action?

No Yes Priority

Remarks:

.....
.....

3. Involving workers in the process of change

How to use the checklist:

A. If you are not reviewing your own enterprise, to provide advice for introducing change you will need some general information. The success of your intervention will depend on the accuracy of the suggestions you provide to the owner. Ask the owner or manager any question you have regarding the situation of the relations between management and workers. You should learn about the current ways workers are informed about the enterprise and how they are involved when changes or innovations occur.

B. Read each item carefully. Look for a way to apply the proposed action. If necessary, ask the owner or workers questions. Before approaching workers, obtain the permission of the owner. If the measure has already been applied or it is not needed, mark "No" under 'Do you propose action?' If you think the measure would be worthwhile, mark "Yes". Use the space under "Remarks" to put a description of your suggestion or its location.

C. After you have finished, look again at the items where you have marked "Yes". Choose a few where the benefits seem to be most important. Mark "Priority" for these items.

D. Before finishing, make sure that for each item you have marked "No" or "Yes", and that you have marked "Priority" where appropriate.

1. Provide workers with basic information about the enterprise, i.e., new products, recognition or claim by clients, incoming or lost contracts, productivity indexes.

Do you propose action?

No Yes Priority

Remarks:

.....
.....

2. Inform workers that you are preparing an action plan for introducing improvements in working conditions.

Do you propose action?

No Yes Priority

Remarks:

.....
.....

3. Inform workers about immediate changes in production processes to be introduced and discuss with them how they are going to be involved.

Do you propose action?

No Yes Priority

Remarks:

.....
.....

4. Implement priority improvement measures to show your concern and sincerity in improving the workplace and make sure they work.

Do you propose action?

No Yes Priority

Remarks:

.....
.....

5. Seek workers' ideas and opinions on problems encountered and possible solutions.

Do you propose action?

No Yes Priority

Remarks:

.....
.....

6. Mobilize worker support by informing them of the problems identified, listening to their opinions and involving workers concerned in planning and implementation of necessary solutions.

Do you propose action?

No Yes Priority

Remarks:

.....
.....

7. Take immediate action for carrying out small improvements and make sure they work.

Do you propose action?

No Yes Priority

Remarks:

.....
.....

8. Organize a meeting of workers or establish a suggestion scheme to hear their opinions on the implemented improvement, remaining problems, and future improvements.

Do you propose action?

No Yes Priority

Remarks:

.....
.....

9. Organize group "walk-through" surveys at regular intervals, as a joint activity of management and workers for identifying new improvement ideas.

Do you propose action?

No Yes Priority

Remarks:

.....
.....

10. Involve workers in problem solving by establishing small group activities to seek suggestions and establish mechanisms to enable workers to participate in the improvement efforts of the enterprise.

Do you propose action?

No Yes Priority

Remarks:

.....
.....

11. Sustain workers' support, involvement and enthusiasm by giving them feedback on improvements and sharing necessary information with them.

Do you propose action?

No Yes Priority

Remarks:

.....
.....

12. Establish a core group of people to develop a complete solution for the problems of cloth materials storage and handling, lighting, fire hazards, worker fatigue, work organization, etc.

Do you propose action?

No Yes Priority

Remarks:

.....
.....

13. Establish a written policy on safety, health, working conditions and productivity.

Do you propose action?

No Yes Priority

Remarks:

.....
.....

14. Inform all employees of such policy through a meeting, bulletin board announcement and distribution of copies of documents.

Do you propose action?

No Yes Priority

Remarks:

.....
.....

15. Share with the workers gains brought about by improved activities of the workers.

Do you propose action?

No Yes Priority

Remarks:

.....
.....

SECTION 3

An exercise to simulate the use of the Kanban method

All you need to practice this simulation technique is to follow these steps:

1. Select one production process requiring handling material in bundles.
2. Get some plastic coffee cups to represent Kanban boxes.
3. Prepare some pieces of paper to represent Kanban cards and put one in each cup.
4. Prepare a model of the target working area on a large piece of brown paper, mapping accurately the position of the sewing (or other) machines with set-up times written nearby.
5. Simulate handling of materials and work-in-process by moving the cups from one workstation to the next. Optimize the procedure.
6. Invite the rest of the workers to view the Kanban simulation exercise. Ask workers to give their ideas on any possible pitfalls such as down-time, late deliveries and rework.

In using this low-cost simulation technique, you can:

- develop and test the Kanban approach before introducing it to the workshop, thus causing a minimum of disruption to production;
- involve some of the workers concerned, to ensure their sense of commitment to the Kanban system, as well as training. Their participation will also ensure a smoother acceptance by other workers and a quicker impact on efficiency and productivity.

SECTION 4

Balancing the production line

To ensure a proper balance in the production line, the following procedure¹ will help you to calculate the minimum and optimum labour balances:

1. List all the operations.
2. List the time value per operation.
3. Calculate the output per standard hour (shr)² per operation.
4. Divide the output per standard hour for each operation into the largest figure calculated, to determine the number of operators and machines required.

Example: Let us assume that product "X" is being manufactured as follows (for the purpose of this example no consideration has been given to the type of machines or handling systems used):

Operation 1: 3.30 standard minutes (sms). Lockstitch badge to placket; placket to front.

Operation 2: 1.65 sms. Overlock placket to front.

Operation 3: 6.60 sms. Overlock body complete.

Operation 4: 2.20 sms. Twin-needle seams.

TOTAL: 13.75 sms.

Minimum balance

1	2	3	4
OP	SMS	SHR	MINIMUM LABOUR BALANCE
1	3.30	18.18	2 operators x 18.18 = 36/HR
2	1.65	36.36	1 operator x 36.36 = 36 HR
3	6.60	9.09	4 operators x 9.09 = 36 HR
4	2.20	27.27	1+1 floater x 27.27 = 55/HR
	<u>13.75</u>		9 operators

$\frac{9 \text{ operators} \times 60 \text{ minutes/hr}}{\text{balanced output} = 36/\text{hr}} = 15.00 \text{ mins per garment}$

$\frac{13.75}{15.00} \times 100 = 91.67\% \text{ (92\% utilization)}$

Optimum balance

1	2	3	4
OP	SMS	SHR	OPTIMUM LABOUR BALANCE
1	3.30	18.18	6 operators x 18.18 = 109/hr
2	1.65	36.36	3 operators x 36.36 = 109/hr
3	6.60	9.09	12 operators x 9.09 = 109/hr
4	2.20	27.27	4 operators x 27.27 = 109/hr
	<u>13.75</u>		25 operators

$\frac{25 \text{ operators} \times 60 \text{ minutes/hr}}{\text{balanced output} = 109/\text{hr}} = 13.76 \text{ mins per garment}$

$\frac{13.75}{13.76} \times 100 = 99.93\% \text{ (100\% utilization)}$

¹Adapted from *Garment Engineering*, by T.M.Pugh (London: The Clothing and Footwear Institute, 1987).

²Standard hours and minutes represent the total time in which a job should be completed at standard performance, i.e. including work content, contingency allowance for delays, unoccupied time and interference allowance, where applicable.

Three techniques for improving your layout

The string diagram

One technique for studying and improving the displacement of workers and materials is the **string diagram**. See figure 1 in this section. It is a scale plan or model on which a thread is used to trace and measure the path of workers, materials or equipment during a specified sequence of events. Thus, it is a sort of flow diagram in which a string or thread is used to measure distance. Because of the need to measure, it is necessary that the string diagram be drawn correctly to scale.

String diagrams start by recording all the relevant facts from direct observation. For this you need to use a very simple study sheet. See example of study sheet in figure 2. To fill the study sheet you need to follow the worker under study as he or she moves from point to point in doing the job. You need to note methodically each point to which the worker moves and, if the journeys are fairly long, the times of arrival and departure as well. It will save a lot of writing if you code the various machines, stores and other points by

numbers, letters or other means. The recording of movements will continue for as long as you think it is necessary to obtain an accurate picture of the worker's movement, which may last a few minutes or hours or a day. In case of long studies, you need to check with the worker concerned to make sure that there is nothing else which is usually done that has not been observed and recorded.

Now you can construct the string diagram. A scale plan of the working area under study must be made. Machines, benches, stores and all points at which calls are made should be drawn in to scale, together with doorways, pillars and partitions that are likely to affect paths of movement. The completed plan should be attached to softwood and pins driven into it firmly at every stopping point, the heads being allowed to stand well clear of the surface (by about 1 cm). Pins should also be driven in at all the turning-points on the route. A piece of thread is then taken and tied round the pin at the starting point of the movements (i.e. the inspection bench I in figure 1). It is then led around the pins at the other points of call in the

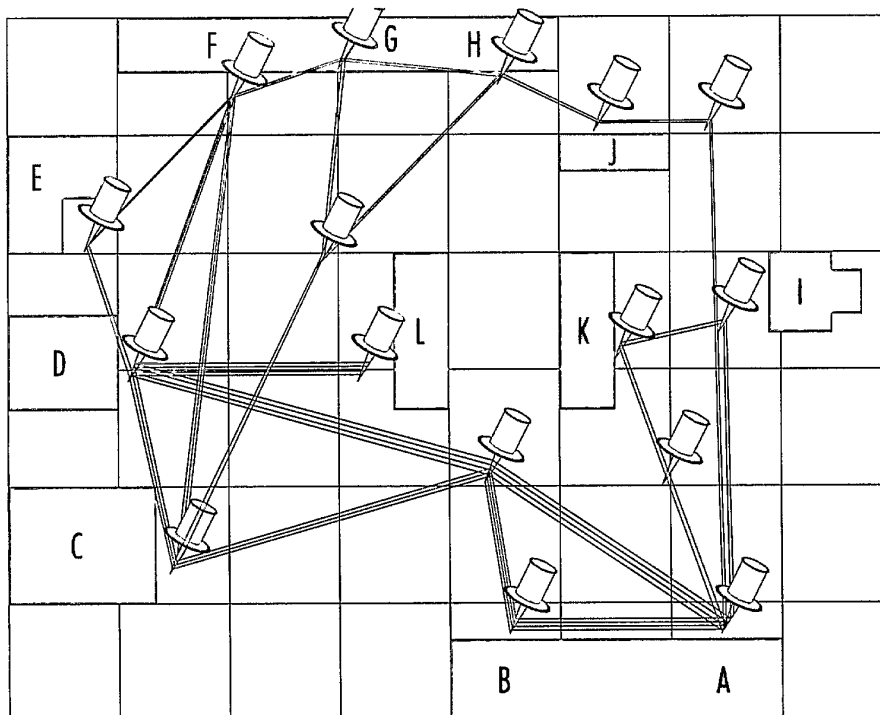

Figure 1: A string diagram

Movement study sheet				
Chart No. 7 Sheet No. 7 of 2			Operative (s)	
Operation: Transport T-shirts				
from inspection to storage			Charted by:	
bins and unload into bins			Date:	
Location: warehouse			Cross-reference: String diagrams	
				1 and 2
1 Time dep.	2 Time arr.	3 Time elapsed	4 Move to	5 Notes
			<i>Inspection bench (I)</i> <i>to Bin 4</i> / 13 / 5 / 32 / 18	

Figure 2:
A simple
movement
study sheet

order noted on the study sheet until all the movements have been dealt with. The length of thread used will represent, to scale, the distance covered by the worker.

The result is an overall picture of the paths of movement of the worker. Those which are most frequently traversed are covered with the greatest number of strings, and as will be seen from the example, certain paths are traversed more frequently than others. Since most of these points are at a fair distance from one another, the diagram suggests that critical examination is called for with a view to moving the work points which they represent closer together. If two or more workers are studied over the same working area, different coloured threads may be used to distinguish between them.

The string diagram is a useful aid for discussing proposed layout changes with the workers concerned. If two diagrams are made, one showing the original layout and another with the improved layout, the contrast is often so vivid – particularly if brightly coloured thread is used – that the change will not be difficult to “sell”. Workers especially are interested in seeing the results of such studies and discovering how far they have to walk. The idea of reducing one’s personal effort appeals to almost everyone.

String diagrams are a very neat tool for supporting improvements, especially when readily understood “before” and “after” models are needed to help in presenting the merits of a proposed change. However, string diagrams do take rather a long time to construct. When a great many movements along complex paths are

involved, the diagram may end up looking like a forbidding maze of criss-crossing lines. When the movement patterns are complex, the travel chart is a quicker and more manageable recording technique.

The travel chart

A travel chart is a tabular record for presenting quantitative data about the movements of workers, materials or equipment between any number of workplaces over any given period of time. Figure 3 shows a typical travel chart. It records the movement of a worker delivering work-in-process to different workstations. The layout of the sector, showing the relative positions of the workstations, is sketched beneath the travel chart.

The travel chart is always a square figure. Each small square represents a workstation. In this example there are ten workstations, numbered 1 to 10 from left to right. The same workstations are again numbered 1 to 10 going down. The travel chart also has a diagonal line drawn across it from top left to bottom right. The squares from left to right along the top of the chart represent the places **from where** movement or travel takes place; those down the left-hand edge represent the workstations **to which** the movement is made. Travel charts are also known as “from-to” charts.

For example, to record a movement from station 2 to station 9, you enter the travel chart at the square numbered 2 along the top and run a pencil down vertically until you reach the square which is horizontally

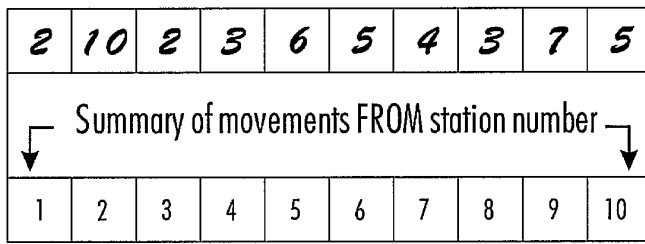
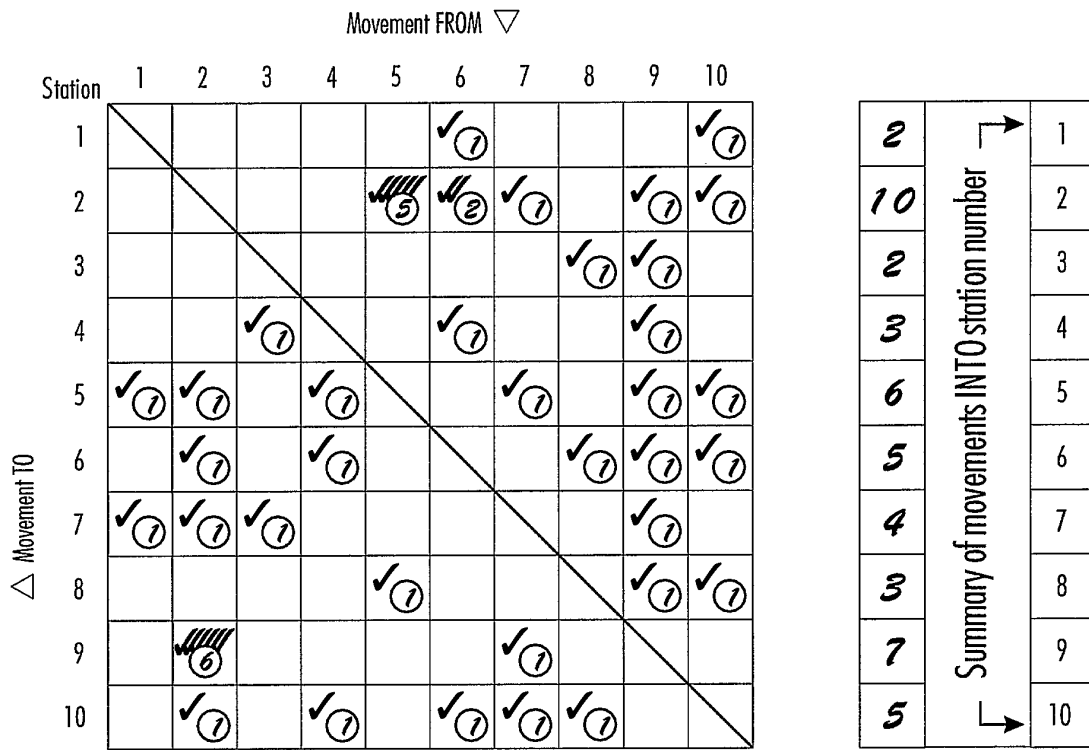

Layout sketch
of workshop
showing location
of sewing stations

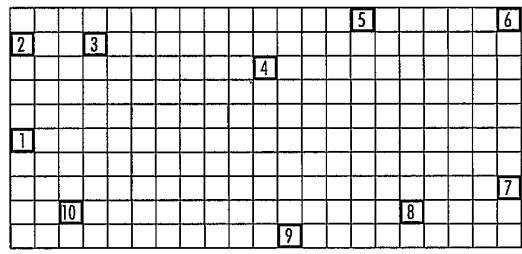

Figure 3: Travel chart: movement of work-in-progress (bundles) in a sewing line

opposite to the station marked 9 on the left-hand edge. This is the terminal square, and you will make a mark (i.e. a small tick) in that square to indicate one journey from station 2 to station 9. All journeys are recorded in the same way.

To make the recording method completely clear, let us suppose that the movement follows this route: from 2 to 9 to 5 to 8 and back to 3. The journey from 2 to 9 will be marked by a tick as described above. To enter the journey from 9 to 5, you will return to the top of the chart, select square 9, move down the column below this until you reach the square opposite to 5 on the left-hand edge and record the movement by a tick there. To the top again to select square 5, down from there to that opposite 8; another tick for that journey. Finally, up to the top once more to select square 8 and down to that opposite number 3 for the recording of the final leg of the movement.

The first stage of the recording process, during the systematic observation of the movements, can be carried out very simply on a study sheet. Once the workstations visited have been numbered and keyed to a sketch of the

workplace, the entries recording the journeys made require very little writing. See figure 4 for another model of a study sheet.

After the movements have been entered on the chart with ticks, the ticks in each small square are added up, the total being entered in the square itself. The movements are then summarized, in two ways. Down the right-hand side of the chart, the number of movements into each workstation is entered against the square representing the station, as read from the left-hand edge. In this example, there were 2 movements into station 1, 10 movements into station 2, etc. Below the chart, the number of movements from each station is recorded, this time under the relevant squares as read off the top of the chart. Similarly, there were 10 movements from station 2, etc.

In this example, the summary of movements into each station shows the same number of movements as those recorded at the bottom as being made from that station. This indicates that the worker finished at the same station as he or she started out from when the study commenced. If the worker had finished somewhere else (or if the study

STUDY SHEET													
Department: <i>Assembling</i>										Study No.: <i>147</i>			
Equipment: <i>Lift Truck: Pallets</i>										Sheet: <i>1 of 2</i>			
Operation: <i>Move 20-kg bundles of material to sewing machines and then to inspection</i>										Taken by: <i>CBA</i>			
										Date:			
<i>From</i>	<i>2</i>	<i>9</i>	<i>7</i>	<i>4</i>	<i>3</i>	<i>9</i>	<i>6</i>	<i>1</i>	<i>9</i>	<i>6</i>	<i>3</i>	<i>2</i>	<i>9</i>
<i>To</i>	<i>9</i>	<i>7</i>	<i>4</i>	<i>3</i>	<i>9</i>	<i>6</i>	<i>1</i>	<i>9</i>	<i>6</i>	<i>3</i>	<i>2</i>	<i>9</i>	<i>7</i>
<i>No. of bundles</i>	<i>10</i>	<i>-</i>	<i>20</i>	<i>10</i>	<i>-</i>	<i>30</i>	<i>10</i>	<i>-</i>	<i>30</i>	<i>10</i>	<i>-</i>	<i>30</i>	<i>-</i>
<i>From</i>	<i>7</i>	<i>1</i>	<i>6</i>	<i>4</i>	<i>9</i>	<i>8</i>	<i>2</i>	<i>5</i>	<i>9</i>	<i>7</i>	<i>2</i>	<i>5</i>	<i>9</i>
<i>To</i>	<i>1</i>	<i>6</i>	<i>4</i>	<i>9</i>	<i>8</i>	<i>2</i>	<i>5</i>	<i>9</i>	<i>7</i>	<i>2</i>	<i>5</i>	<i>9</i>	<i>6</i>
<i>No. of bundles</i>	<i>10</i>	<i>20</i>	<i>-</i>	<i>30</i>	<i>40</i>	<i>20</i>	<i>30</i>	<i>40</i>	<i>10</i>	<i>20</i>	<i>10</i>	<i>30</i>	<i>40</i>
<i>From</i>	<i>6</i>	<i>1</i>	<i>9</i>										
<i>To</i>	<i>1</i>	<i>9</i>	<i>6</i>										
<i>No. of bundles</i>	<i>-</i>	<i>30</i>	<i>30</i>										

Figure 4: A simple study sheet

had been broken off at any moment), there would have been one station where there was one more movement in than the number of movements out.

An examination of the chart shows which are the busiest routes and stations. This suggests that it would be better to locate these stations next to each other.

Weighted travel charts

If to the movements of a worker you add the number of garment pieces or containers carried, then you will have a weighted "from-to" chart. For this you only need to multiply the number of trips (or the distance travelled, if you have a "string" diagram available) by the number of containers or kilos transported. You may also consider another factor: the cost of transportation. For this you need to further multiply the former numbers by the total time spent in handling (i.e. in hours) multiplied by the

remuneration per hour. Thus, each entry would represent the cost of materials handling. As the sum of the individual costs represents the total materials-handling cost, this can be used to evaluate alternative layout designs. See figure 5 for an example of a weighted travel chart.

If you use the number of bundles moved between workstations as the unit of measurement, you will see that the bundles BELOW the diagonal are back-tracking, whilst those above it are progressing forward.

Try moving the workstation columns and rows until you get the greatest number just ABOVE the diagonal. If you then arrange the workstations in this order, you will have the largest number of bundles moving from one station to the next in sequence. By keeping as many bundles as possible ABOVE the diagonal, you will minimize back-tracking and maximize forward progress of the work, reducing the chances of bundles being lost due to confusion with other bundles at an earlier stage of manufacture.

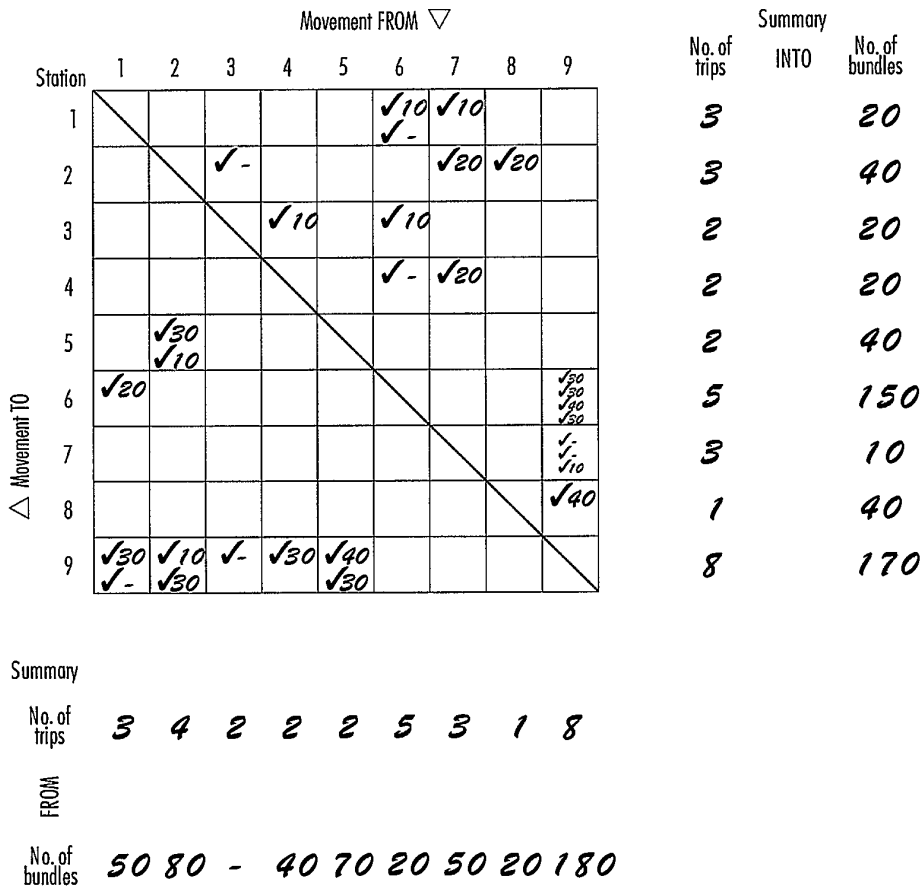

Figure 5: Weighted travel chart: materials handling

Checklist 4: How to implement improvements

Avoid wasting your time and money implementing important improvements in a careless way. Even simple improvements often fail because of lack of foresight and planning. This guide gives five simple rules that will help you to be successful. In addition, they will help you to make improvements happen frequently instead of stopping after three or four have been completed. Remember: Continuous improvement is the road to survival and growth.

DEVELOP A COMPLETE SOLUTION

Improvements sometimes don't work because they are incomplete. For example, if you want to use carts, you should take a look at the shop-floor. Will additional changes be necessary to make the improvement work well:

in materials storage and handling?
.....
.....

in workstation design?
.....
.....

in productive machine safety, maintenance and environmental control?
.....
.....

in lighting?
.....
.....

in welfare facilities?
.....
.....

in premises?
.....
.....

in work organization?
.....
.....

MAKE SURE IDEAS WILL WORK

Very often, even improvements which seem simple do not meet your expectations in practice. Anticipate design problems and make sure that all important factors have been taken into account. Ask yourself what makes you believe that this improvement will work well:

because you have tried out different ways of solving the same problem and this one works best

because you have tried it out in a small way and it works well

because you have seen it work under the same conditions in another enterprise

because you have the advice of someone who has done the same thing

because:
.....
.....

If you are not sure that this idea for improvement will work best, what steps will you take to find out?

.....
.....
.....

MOBILIZE WORKER SUPPORT

Your programme of improvements will fulfil your expectations only with the good will and support of those who are directly affected by the changes. Your workers will be on your side if they fully understand that the changes are in their interests as well as yours.

Are you sure that the improvement will not cause any problems for your workers? Ask yourself:

Who will be directly affected by the change?

In what way will they be affected?

Positively? Negatively?

.....
.....

What will you do to eliminate or reduce negative effects?

.....
.....

In order for workers to support your plans for change, they need to understand your intentions. They may think that the changes will affect their job security or pay or make their work more difficult.

What techniques will you use to make sure that your workers are ready for the change and that they give you credit for what you are doing?

- prior explanation and discussion
- involving workers in the design and introduction of the improvement
- showing how this innovation works in another shop or factory
- provision of additional training
- financial rewards.

MAKE IMPROVEMENTS THAT WILL LAST

Four innovations out of five eventually disappear because no specific actions were taken to make them last. There are two main strategies which will help to counteract this:

- change people's habits and behaviour
- build the change into equipment and facilities.

For most changes you will need to do both to be successful.

If you follow this method carefully and involve workers fully, you should make much progress in changing workers' habits and motivation. However, if the improvement is fully dependent on the behaviour of the worker (for example, preventing the cluttering of passageways), it is very likely that it will not last long. Old habits are hard to change. To prevent this, you have to find ways of incorporating change into machines and facilities, so that the new organizational process makes the old routine impossible (for example, provide storage racks and bins, or clearly mark passageways).

Which steps will you take to make the change last by incorporating it into your plant and equipment?

- remove any tools or equipment which make it possible or easier to return to the old situation
- build the improvement into machines or workstations so that it cannot be removed
- design new or modify existing equipment so that it is easier to use and maintain in the new way
- provide barriers, painted lines, bins, or make other changes which make the improvement easily visible and natural to follow.

.....
.....

MANAGE CHANGE

Be sure that changes will be effectively implemented. Foresee the following steps:

- establish a firm deadline
- make someone responsible for implementation
- allocate adequate resources (time, materials, money)
- request regular reports on progress

check that the implemented improvement works well, is accepted by the workers and has no unexpected results

make sure that you and your supervisors lead the way by following rules and by frequently praising workers who respond correctly to the improvement.

An important management responsibility is to make sure that the improvement becomes a permanent part of the way work is carried out. Ask yourself:

- do you receive a constant flow of ideas from your staff and workers?

- is everyone in search of ways for more productive or higher quality work?

The following steps will help to make your enterprise more dynamic:

- a regular suggestion scheme with rewards for the best ideas
- regular meetings at which workers are encouraged to explain their problems and give their ideas
- an exercise in which groups of workers use the checklist and make proposals to you
- organize a core group for taking care of changes.

Model forms for an action plan

SECTION 7

The completed form below may be helpful as an example of how to complete your action plan. The second form is blank so that it can be used as it is or adapted to specific needs.

Separate sheets should be prepared for each of the following subjects: materials storage and handling, workstations and product design; productive machine safety, maintenance and environmental control, lighting, work-related welfare facilities and benefits, premises, work organization.

ACTION PLAN				Date: <i>July 1998</i>
<i>Type of improvement: Materials storage and handling</i>				
Location inside the factory	Description	Responsible	Approximate completion date	
<i>Whole factory</i>	<i>Clear passageways and paint lines</i>	<i>Supervisor</i>	<i>Mid August</i>	
<i>Near storage areas</i>	<i>Construct wheeled containers</i>	<i>Supervisor + Two maintenance workers</i>	<i>End August</i>	
<i>Main workrooms</i>	<i>Repair holes in floor</i>	<i>One maintenance worker</i>	<i>First week August</i>	
<i>Main workrooms</i>	<i>Build storage racks</i>	<i>Supervisor + welder</i>	<i>End September</i>	
<i>Main workrooms</i>	<i>Label storage racks</i>	<i>All sewers and supervisor</i>	<i>Mid October</i>	
<i>Main workrooms</i>	<i>Clear work tables and benches</i>	<i>All sewers</i>	<i>Immediately</i>	
<i>Under stairs</i>	<i>Move boxes to storage</i>	<i>Supervisor</i>	<i>Immediately</i>	
<i>Exit B</i>	<i>Move boxes away to storage</i>	<i>Supervisor</i>	<i>Immediately</i>	
<i>Main workrooms</i>	<i>Install long tables</i>	<i>Supervisor + One maintenance worker</i>	<i>End August</i>	
<i>Main workrooms/passageway C</i>	<i>Build ramp wide enough for wheeled containers</i>	<i>Carpenter</i>	<i>End October</i>	

ACTION PLAN

Type of improvement: _____ Date: _____

Location inside the factory	Description	Responsible	Approximate completion date

Other ILO publications

Higher productivity and a better place to work: Action manual

J.E. Thurman, K. Kogi and A.E. Louzine

How can you take effective, low-cost action which will raise productivity while improving workplace conditions? This heavily illustrated, easy-to-follow book, designed for owners and managers of small and medium-sized enterprises, starts with a checklist that proposes practical solutions to common shop-floor problems. This is followed by action-oriented chapters that provide simple, sensible rules which are easy to apply. Many useful examples are provided on the following key topics: the storage and handling of materials; lighting; workstation design; welfare facilities and services; productive machine safety; work premises; control of hazardous substances; and work organization. Low productivity and poor work quality often result from the same difficulties and lack of organization that make work hazardous and unpleasant. Moreover, in those factories where management develops a long-term commitment to improvements in productivity, the involvement of workers is part of the strategy of motivation and change. A trainer's manual in the form of a loose-leaf binder is also available.

ISBN 92-2-106409-3

20 Swiss francs

Ergonomic checkpoints: Practical and easy-to-implement solutions for improving safety, health and working conditions

This unique compilation of 127 "ergonomic checkpoints" identifies simple and inexpensive solutions to ergonomic problems in a variety of workplaces and local situations. The checkpoints, which can be used to check working conditions or workplace plans, cover storage and handling, hand tools, machine safety, workstation design, lighting, premises, hazardous substances, welfare facilities and work organization. Each checkpoint is illustrated, and a complete ergonomic checklist is included.

ISBN 92-2-109442-1

25 Swiss francs

Work organization and ergonomics,

edited by Vittorio Di Martino and Nigel Corlett

This book shows how to use ergonomics and to improve working conditions, increase productivity and enhance quality and performance. It draws together some of the basic changes being applied by enterprises worldwide, and explains briefly what they are and how others can benefit from them. It looks at practical aspects, where knowledge from research and applications of ergonomics have been used to match the work environment to the needs and characteristics of workers and processes. This has involved removing obstacles to the workers' ability to work effectively and efficiently to produce high-quality output, and creating human-oriented and ergonomically sound environments. This will lead to major gains for workers and employers. The book is aimed at managers, supervisors, workers' representatives, engineers, trainers and consultants, particularly those engaged in processes of transformation and innovation. The authors are international experts in engineering, ergonomics, social sciences and work organization.

ISBN 92-2-109518-5

25 Swiss francs

Management development: A guide for the profession

edited by J. Prokopenko

This guide provides practical information relating to the need to update management training and development approaches, methods and techniques in the light of global economic trends and new management practices. The principal aim of this book is to function as an international guide to managers, management consultants and management development professionals based on a solid theoretical approach and reflecting the best practices of business firms, public organizations, training and development institutions, business and management schools and management consultants in various countries. Written by experts in the field from around the world.

ISBN 92-2-109196-1

45 Swiss francs

Prices subject to change without notice

IMPROVING WORKING CONDITIONS AND PRODUCTIVITY IN THE GARMENT INDUSTRY

If you own or manage a small or medium-sized enterprise producing garments, you are responsible for an important contribution to the national economy. People depend on you for jobs and for your products. The bulk of social and economic growth in most countries is expected to come from small or medium-sized enterprises.

In spite of their importance, many small or medium-sized clothing firms fail to grow or even to survive. It is not easy to succeed in the garment industry. Problems of finance, production and marketing lead many to bankruptcy every year.

This is a book about survival and growth through building a more effective enterprise. The ideas you will find in this book are practical and low cost: some of them may already be in use in your own enterprise or nearby. These practical ideas are the result of several years of ILO action, in cooperation with owners and managers just like you. In each case, the starting point was a concern for the enterprise's survival and growth.

Part 1 includes many low-cost improvements in:

- **Efficient materials storage and handling**
- **Practical workstation and product design**
- **Productive machine safety, maintenance and environmental control**
- **Good lighting for quality products**
- **Useful premises serving production**
- **Effective work organization and work processes**
- **Low-cost work-related welfare facilities and benefits.**

Part 1 also offers practical procedures to help you take action, involve your workers in the process of change and assess the impact of the changes. **Part 2** provides tools for action, such as procedures and examples for assessing productivity; checklists for identifying possible improvements in working conditions; and forms and worksheets for keeping records of changes.

This book may be used by entrepreneurs participating in courses organized by employers' organizations, productivity centres, training institutions, labour ministries or other agencies, as well as by individual readers.

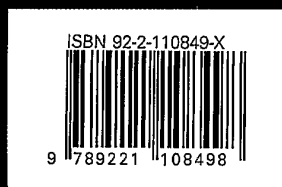

Price: 30 Swiss francs